

Discrete Mathematics

MTH202



Virtual University of Pakistan

Knowledge beyond the boundaries

Table of Contents

LECTURE NO.1	LOGIC	3
LECTURE NO.2	TRUTH TABLES	8
LECTURE NO.3	LAWS OF LOGIC	14
LECTURE NO.4	BICONDITIONAL	20
LECTURE NO.5	ARGUMENT	25
LECTURE NO.6	APPLICATIONS OF LOGIC	30
LECTURE NO.7	SET THEORY	37
LECTURE NO.8	VENN DIAGRAM	42
LECTURE NO.9	SET IDENTITIES	54
LECTURE NO.10	APPLICATIONS OF VENN DIAGRAM	61
LECTURE NO.11	RELATIONS	70
LECTURE NO.12	TYPES OF RELATIONS	77
LECTURE NO.13	MATRIX REPRESENTATION OF RELATIONS	88
LECTURE NO.14	INVERSE OF RELATIONS	95
LECTURE NO.15	FUNCTIONS	101
LECTURE NO.16	TYPES OF FUNCTIONS	111
LECTURE NO.17	INVERSE FUNCTION	123
LECTURE NO.18	COMPOSITION OF FUNCTIONS	134
LECTURE NO.19	SEQUENCE	144
LECTURE NO.20	SERIES	150
LECTURE NO.21	RECURSION I	159
LECTURE NO.22	RECURSION II	165
LECTURE NO.23	MATHEMATICAL INDUCTION	170
LECTURE NO.24	MATHEMATICAL INDUCTION FOR DIVISIBILITY	179
LECTURE NO.25	METHODS OF PROOF	186
LECTURE NO.26	PROOF BY CONTRADICTION	193
LECTURE NO.27	ALGORITHM	201
LECTURE NO.28	DIVISION ALGORITHM	205
LECTURE NO.29	COMBINATORICS	209
LECTURE NO.30	PERMUTATIONS	217
LECTURE NO.31	COMBINATIONS	225
LECTURE NO.32	K-COMBINATIONS	231
LECTURE NO.33	TREE DIAGRAM	237
LECTURE NO.34	INCLUSION-EXCLUSION PRINCIPLE	245
LECTURE NO.35	PROBABILITY	250
LECTURE NO.36	LAWS OF PROBABILITY	257
LECTURE NO.37	CONDITIONAL PROBABILITY	267
LECTURE NO.38	RANDOM VARIABLE	274
LECTURE NO.39	INTRODUCTION TO GRAPHS	283
LECTURE NO.40	PATHS AND CIRCUITS	292
LECTURE NO.41	MATRIX REPRESENTATION OF GRAPHS	298
LECTURE NO.42	ISOMORPHISM OF GRAPHS	305
LECTURE NO.43	PLANAR GRAPHS	314
LECTURE NO.44	TREES	321
LECTURE NO.45	SPANNING TREES	329

Lecture No.1 Logic**Course Objective:**

1. Express statements with the precision of formal logic
2. Analyze arguments to test their validity
3. Apply the basic properties and operations related to sets
4. Apply to sets the basic properties and operations related to relations and function
5. Define terms recursively
6. Prove a formula using mathematical induction
7. Prove statements using direct and indirect methods
8. Compute probability of simple and conditional events
9. Identify and use the formulas of combinatorics in different problems
10. Illustrate the basic definitions of graph theory and properties of graphs
11. Relate each major topic in Discrete Mathematics to an application area in computing

1. Recommended Books:

1. Discrete Mathematics with Applications (second edition) by Susanna S. Epp
2. Discrete Mathematics and Its Applications (fourth edition) by Kenneth H. Rosen
1. Discrete Mathematics by Ross and Wright

MAIN TOPICS:

1. Logic
2. Sets & Operations on sets
3. Relations & Their Properties
4. Functions
5. Sequences & Series
6. Recurrence Relations
7. Mathematical Induction
8. Loop Invariants
9. Combinatorics
10. Probability
11. Graphs and Trees

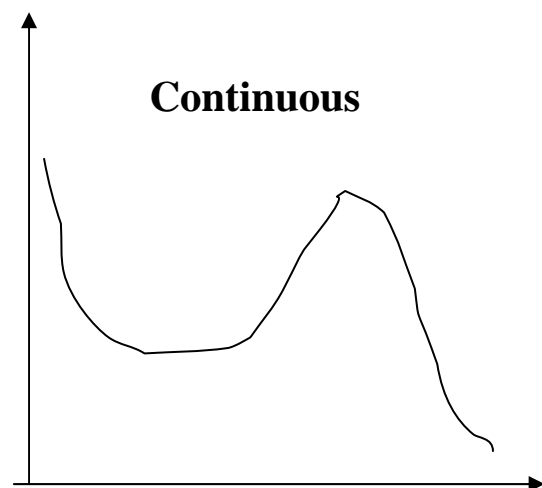
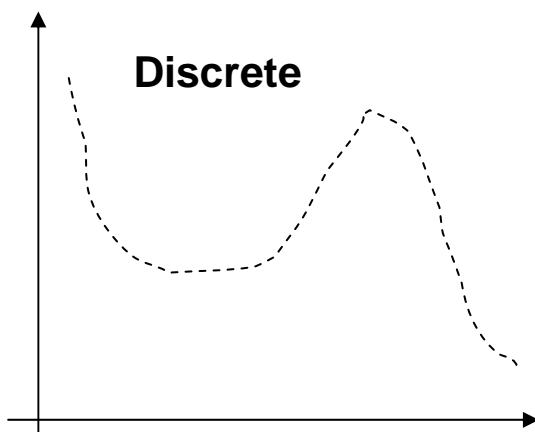

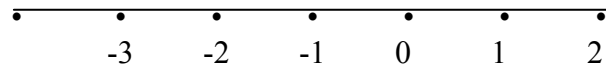
Set of Integers:**Set of Real Numbers:****What is Discrete Mathematics?:**

Discrete Mathematics concerns processes that consist of a sequence of individual steps.

LOGIC:

Logic is the study of the principles and methods that distinguishes between a valid and an invalid argument.

SIMPLE STATEMENT:

A statement is a declarative sentence that is either true or false but not both.

A statement is also referred to as a proposition

Example: $2+2 = 4$, It is Sunday today

If a proposition is true, we say that it has a **truth value** of "**true**".

If a proposition is false, its truth value is "**false**".

The truth values "**true**" and "**false**" are, respectively, denoted by the letters **T** and **F**.

EXAMPLES:

1. Grass is green.

$2.4 + 2 = 6$

$2.4 + 2 = 7$

3. There are four fingers in a hand.

are propositions

Not Propositions

- Close the door.
 - x is greater than 2.
 - He is very rich
- are not propositions.

Rule:

If the sentence is preceded by other sentences that make the pronoun or variable reference clear, then the sentence is a statement.

Example:

$x = 1$

$x > 2$

$x > 2$ is a statement with truth-value

FALSE.

Example

Bill Gates is an American

He is very rich

He is very rich is a statement with truth-value
TRUE.

UNDERSTANDING STATEMENTS:

- | | |
|--------------------------|-----------------|
| 1. $x + 2$ is positive. | Not a statement |
| 2. May I come in? | Not a statement |
| 3. Logic is interesting. | A statement |
| 4. It is hot today. | A statement |
| 5. $-1 > 0$ | A statement |
| 6. $x + y = 12$ | Not a statement |

COMPOUND STATEMENT:

Simple statements could be used to build a compound statement.

EXAMPLES:**LOGICAL CONNECTIVES**

1. “ $3 + 2 = 5$ ” and “Lahore is a city in Pakistan”
2. “The grass is green” or “ It is hot today”
3. “Discrete Mathematics is **not** difficult to me”

AND, OR, NOT are called LOGICAL CONNECTIVES.

SYMBOLIC REPRESENTATION:

Statements are symbolically represented by letters such as p, q, r, \dots

EXAMPLES:

p = “Islamabad is the capital of Pakistan”

q = “17 is divisible by 3”

CONNECTIV	MEANING	SYMBOL	CALLED
Negation	not	\sim	Tilde
Conjunction	and	\wedge	Hat
Disjunction	or	\vee	Vel
Conditional	if...then...	\rightarrow	Arrow
Biconditional	if and only if	\leftrightarrow	Double arrow

EXAMPLES:

p = “Islamabad is the capital of Pakistan”

q = “17 is divisible by 3”

$p \wedge q$ = “Islamabad is the capital of Pakistan and 17 is divisible by 3”

$p \vee q$ = “Islamabad is the capital of Pakistan or 17 is divisible by 3”

$\sim p$ = “It is not the case that Islamabad is the capital of Pakistan” or simply “Islamabad is not the capital of Pakistan”

TRANSLATING FROM ENGLISH TO SYMBOLS:

Let p = “It is hot”, and q = “It is sunny”

SENTENCE**SYMBOLIC FORM**

1. It is **not** hot.

$\sim p$

2. It is hot **and** sunny.

$p \wedge q$

3. It is hot **or** sunny.

$p \vee q$

4. It is **not** hot **but** sunny.

$\sim p \wedge q$

5. It is **neither** hot **nor** sunny.

$$\sim p \wedge \sim q$$

EXAMPLE:

Let h = "Zia is healthy"

w = "Zia is wealthy"

s = "Zia is wise"

Translate the compound statements to symbolic form:

1. Zia is healthy and wealthy but not wise. $(h \wedge w) \wedge (\sim s)$

2. Zia is not wealthy but he is healthy and wise. $\sim w \wedge (h \wedge s)$

3. Zia is neither healthy, wealthy nor wise. $\sim h \wedge \sim w \wedge \sim s$

TRANSLATING FROM SYMBOLS TO ENGLISH:

Let m = "Ali is good in Mathematics"

c = "Ali is a Computer Science student"

Translate the following statement forms into plain English:

1. $\sim c$ Ali is **not** a Computer Science student

2. $c \vee m$ Ali is a Computer Science student **or** good in Maths.

3. $m \wedge \sim c$ Ali is good in Maths **but not** a Computer Science student

A convenient method for analyzing a compound statement is to make a truth table for it.

A **truth table** specifies the truth value of a compound proposition for all possible truth values of its constituent propositions.

NEGATION (\sim):

If p is a statement variable, then negation of p , "**not p** ", is denoted as " **$\sim p$** "

It has opposite truth value from p i.e.,

if p is true, $\sim p$ is false; if p is false, $\sim p$ is true.

TRUTH TABLE FOR

$\sim p$

p	$\sim p$
T	F
F	T

CONJUNCTION (\wedge):

If p and q are statements, then the conjunction of p and q is " **p and q** ", denoted as " **$p \wedge q$** ".

It is true when, and only when, both p and q are true. If either p or q is false, or if both are false, $p \wedge q$ is false.

TRUTH TABLE FOR **$p \wedge q$**

p	q	$p \wedge q$
T	T	T
T	F	F
F	T	F
F	F	F

DISJUNCTION (\vee)**or INCLUSIVE OR**

If p & q are statements, then the disjunction of p and q is “ p or q ”, denoted as “ $p \vee q$ ”. It is true when at least one of p or q is true and is false only when both p and q are false.

TRUTH TABLE FOR **$p \vee q$**

p	q	$p \vee q$
T	T	T
T	F	T
F	T	T
F	F	F

Note it that in the table F is only in that row where both p and q have F and all other values are T. Thus for finding out the truth values for the disjunction of two statements we will only first search out where the both statements are false and write down the F in the corresponding row in the column of $p \vee q$ and in all other rows we will write T in the column of $p \vee q$.

Remark:

Note that for Conjunction of two statements we find the T in both the statements, but in disjunction we find F in both the statements. In other words we will fill T first in the column of conjunction and F in the column of disjunction.

SUMMARY

1. What is a statement?
2. How a compound statement is formed.
3. Logical connectives (negation, conjunction, disjunction).
4. How to construct a truth table for a statement form.

Lecture No.2

Truth Tables

Truth Tables

Truth Tables for:

1. $\sim p \wedge q$
2. $\sim p \wedge (q \vee \sim r)$
3. $(p \vee q) \wedge \sim (p \wedge q)$

Truth table for the statement form $\sim p \wedge q$

p	q	$\sim p$	$\sim p \wedge q$
T	T	F	F
T	F	F	F
F	T	T	T
F	F	T	F

Truth table for $\sim p \wedge (q \vee \sim r)$

p	q	r	$\sim r$	$q \vee \sim r$	$\sim p$	$\sim p \wedge (q \vee \sim r)$
T	T	T	F	T	F	F
T	T	F	T	T	F	F
T	F	T	F	F	F	F
T	F	F	T	T	F	F
F	T	T	F	T	T	T
F	T	F	T	T	T	T
F	F	T	F	F	T	F
F	F	F	T	T	T	T

Truth table for $(p \vee q) \wedge \sim (p \wedge q)$

p	q	$p \vee q$	$p \wedge q$	$\sim (p \wedge q)$	$(p \vee q) \wedge \sim (p \wedge q)$
T	T	T	T	F	F
T	F	T	F	T	T
F	T	T	F	T	T
F	F	F	F	T	F

Double Negative Property $\sim(\sim p) \equiv p$

p	$\sim p$	$\sim(\sim p)$
T	F	T
F	T	F

Example**“It is not true that I am not happy”**Solution:Let $p =$ “I am happy”then $\sim p =$ “I am not happy”and $\sim(\sim p) =$ “It is not true that I am not happy”Since $\sim(\sim p) \equiv p$

Hence the given statement is equivalent to:

“I am happy” $\sim(p \wedge q)$ and $\sim p \wedge \sim q$ are not logically equivalent

p	q	$\sim p$	$\sim q$	$p \wedge q$	$\sim(p \wedge q)$	$\sim p \wedge \sim q$
T	T	F	F	T	F	F
T	F	F	T	F	T	F
F	T	T	F	F	T	F
F	F	T	T	F	T	T

Different truth values in row 2 and row 3

DE MORGAN'S LAWS:1) The negation of an **and** statement is logically equivalent to the **or** statement in which each component is negated.Symbolically $\sim(p \wedge q) \equiv \sim p \vee \sim q$.2) The negation of an **or** statement is logically equivalent to the **and** statement in which each component is negated.Symbolically: $\sim(p \vee q) \equiv \sim p \wedge \sim q$. $\sim(p \vee q) \equiv \sim p \wedge \sim q$

p	q	$\sim p$	$\sim q$	$p \vee q$	$\sim(p \vee q)$	$\sim p \wedge \sim q$
T	T	F	F	T	F	F
T	F	F	T	T	F	F
F	T	T	F	T	F	F
F	F	T	T	F	T	T



Same truth values

Application:

Give negations for each of the following statements:

- The fan is slow **or** it is very hot.
- Akram is unfit **and** Saleem is injured.

Solution

- The fan is **not** slow **and** it is **not** very hot.
- Akram is **not** unfit **or** Saleem is **not** injured.

INEQUALITIES AND DEMORGAN'S LAWS:

Use DeMorgan's Laws to write the negation of

$$-1 < x \leq 4$$

for some particular real no. x

$$-1 < x \leq 4 \text{ means } x > -1 \text{ and } x \leq 4$$

By DeMorgan's Law, the negation is:

$$x > -1 \text{ or } x \leq 4 \text{ Which is equivalent to: } x \leq -1 \text{ or } x > 4$$

EXERCISE:

- $(p \wedge q) \wedge r \equiv p \wedge (q \wedge r)$
- Are the statements $(p \wedge q) \vee r$ and $p \wedge (q \vee r)$ logically equivalent?

TAUTOLOGY:

A tautology is a statement form that is always true regardless of the truth values of the statement variables.

A tautology is represented by the symbol "T"..

EXAMPLE: The statement form $p \vee \sim p$ is tautology

p	$\sim p$	$p \vee \sim p$
T	F	T
F	T	T

$$p \vee \sim p \equiv t$$

CONTRADICTION:

A contradiction is a statement form that is always false regardless of the truth values of the statement variables.

A contradiction is represented by the symbol “c”.

So if we have to prove that a given statement form is **CONTRADICTION** we will make the truth table for the statement form and if in the column of the given statement form all the entries are F, then we say that statement form is contradiction.

EXAMPLE:

The statement form $p \wedge \sim p$ is a contradiction.

p	$\sim p$	$p \wedge \sim p$
T	F	F
F	T	F

Since in the last column in the truth table we have F in all the entries so is a contradiction $p \wedge \sim p \equiv c$

REMARKS:

- Most statements are neither tautologies nor contradictions.
- The negation of a tautology is a contradiction and vice versa.
- In common usage we sometimes say that two statements are contradictory.

By this we mean that their conjunction is a contradiction: they cannot both be true.

LOGICAL EQUIVALENCE INVOLVING TAUTOLOGY

1. Show that $p \wedge t \equiv p$

p	t	$p \wedge t$
T	T	T
F	T	F

Since in the above table the entries in the first and last columns are identical so we have the corresponding statement forms are Logically Equivalent that is

$$p \wedge t \equiv p$$

LOGICAL EQUIVALENCE INVOLVING CONTRADICTION

Show that $p \wedge c \equiv c$

p	c	$p \wedge c$
T	F	F
F	F	F

Same truth values in the indicated columns so $p \wedge c \equiv c$

EXERCISE:

Use truth table to show that $(p \wedge q) \vee (\sim p \vee (p \wedge \sim q))$ is a tautology.

SOLUTION:

Since we have to show that the given statement form is Tautology so the column of the above proposition in the truth table will have all entries as T.

As clear from the table below

p	Q	$p \wedge q$	$\sim p$	$\sim q$	$p \wedge \sim q$	$\sim p \vee (p \wedge \sim q)$	$(p \wedge q) \vee (\sim p \vee (p \wedge \sim q))$
T	T	T	F	F	F	F	T
T	F	F	F	T	T	T	T
F	T	F	T	F	F	T	T
F	F	F	T	T	F	T	T

Hence $(p \wedge q) \vee (\sim p \vee (p \wedge \sim q)) \equiv t$

EXERCISE:

Use truth table to show that $(p \wedge \sim q) \wedge (\sim p \vee q)$ is a contradiction.

SOLUTION:

Since we have to show that the given statement form is Contradiction so its column in the truth table will have all entries as F.

As clear from the table below

p	q	$\sim q$	$p \wedge \sim q$	$\sim p$	$\sim p \vee q$	$(p \wedge \sim q) \wedge (\sim p \vee q)$
T	T	F	F	F	T	F
T	F	T	T	F	F	F
F	T	F	F	T	T	F
F	F	T	F	T	T	F

USAGE OF "OR" IN ENGLISH

In English language the word **or** is sometimes used in an inclusive sense (p or q or both).

Example: I shall buy a pen or a book.

In the above statement, if you buy a pen or a book in both cases the statement is true and if you buy (both) pen and book then statement is again true. Thus we say in the above statement we use or in inclusive sense.

The word or is sometimes used in an exclusive sense (p or q but not both). As in the below statement

Example: Tomorrow at 9, I'll be in Lahore or Islamabad.

Now in above statement we are using or in exclusive sense because both the statements are true then we have F for the statement.

While defining a disjunction the word or is used in its inclusive sense. Thus the symbol \vee means the "inclusive or"

EXCLUSIVE OR:

When or is used in its exclusive sense, the statement “p or q” means “p or q but not both” or “p or q and not p and q” which translates into symbols as:

$$(p \vee q) \wedge \sim (p \wedge q)$$

Which is abbreviated as:

$$p \oplus q$$

or **p XOR q**

TRUTH TABLE FOR EXCLUSIVE OR:

p	q	$p \vee q$	$p \wedge q$	$\sim (p \wedge q)$	$(p \vee q) \wedge \sim (p \wedge q)$
T	T	T	T	F	F
T	F	T	F	T	T
F	T	T	F	T	T
F	F	F	F	T	F

Note:

Basically

$$\begin{aligned} p \oplus q &\equiv (p \wedge \sim q) \vee (\sim p \wedge q) \\ &\equiv [p \wedge \sim q] \vee \sim p \wedge [(p \wedge \sim q) \vee q] \\ &\equiv (p \vee q) \wedge \sim (p \wedge q) \\ &\equiv (p \vee q) \wedge (\sim p \vee \sim q) \end{aligned}$$

Lecture No.3

Laws of Logic

APPLYING LAWS OF LOGIC

Using law of logic, simplify the statement form

$$p \vee [\sim(\sim p \wedge q)]$$

Solution:

$$\begin{aligned} p \vee [\sim(\sim p \wedge q)] &\equiv p \vee [\sim(\sim p) \vee (\sim q)] \\ &\equiv p \vee [p \vee (\sim q)] \\ &\equiv [p \vee p] \vee (\sim q) \\ &\equiv p \vee (\sim q) \end{aligned}$$

DeMorgan's Law
Double Negative Law
Associative Law for \vee
Indempotent Law

This is the simplified statement form.

EXAMPLE Using Laws of Logic, verify the logical equivalence

$$\begin{aligned} \sim(\sim p \wedge q) \wedge (p \vee q) &\equiv p \\ \sim(\sim p \wedge q) \wedge (p \vee q) &\equiv (\sim(\sim p) \vee \sim q) \wedge (p \vee q) && \text{DeMorgan's Law} \\ &\equiv (p \vee \sim q) \wedge (p \vee q) && \text{Double Negative Law} \\ &\equiv p \vee (\sim q \wedge q) && \text{Distributive Law} \\ &\equiv p \vee c && \text{Negation Law} \\ &\equiv p && \text{Identity Law} \end{aligned}$$

SIMPLIFYING A STATEMENT:

"You will get an A if you are hardworking and the sun shines, or you are hardworking and it rains."

Rephrase the condition more simply.

Solution:

$$\begin{aligned} \text{Let } p &= \text{"You are hardworking"} \\ q &= \text{"The sun shines"} \\ r &= \text{"It rains"} \end{aligned} \text{ .The condition is then } (p \wedge q) \vee (p \wedge r)$$

And using distributive law in reverse,

$$(p \wedge q) \vee (p \wedge r) \equiv p \wedge (q \vee r)$$

Putting $p \wedge (q \vee r)$ back into English, we can rephrase the given sentence as

"You will get an A if you are hardworking and the sun shines or it rains."

EXERCISE:

Use Logical Equivalence to rewrite each of the following sentences more simply.

1. It is not true that I am tired and you are smart.

{I am not tired or you are not smart.}

2. It is not true that I am tired or you are smart.

{I am not tired and you are not smart.}

3. I forgot my pen or my bag and I forgot my pen or my glasses.

{I forgot my pen or I forgot my bag and glasses.}

4. It is raining and I have forgotten my umbrella, or it is raining and I have forgotten my hat.

{It is raining and I have forgotten my umbrella or my hat.}

CONDITIONAL STATEMENTS:**Introduction**

Consider the statement:

"If you earn an A in Math, then I'll buy you a computer."

This statement is made up of two simpler statements:

p: "You earn an A in Math," and

q: "I will buy you a computer."

The original statement is then saying:

if p is true, then q is true, or, more simply, if p, then q.

We can also phrase this as p **implies** q, and we write **$p \rightarrow q$** .

CONDITIONAL STATEMENTS OR IMPLICATIONS:

If p and q are statement variables, the conditional of q by p is "If p then q" or "p implies q" and is denoted $p \rightarrow q$.

It is false when p is true and q is false; otherwise it is true. The arrow " \rightarrow " is the **conditional** operator, and in $p \rightarrow q$ the statement p is called the **hypothesis** (or **antecedent**) and q is called the conclusion (or consequent).

TRUTH TABLE:

p	q	$p \rightarrow q$
T	T	T
T	F	F
F	T	T
F	F	T

PRACTICE WITH CONDITIONAL STATEMENTS:

Determine the truth value of each of the following conditional statements:

1. "If $1 = 1$, then $3 = 3$." **TRUE**
2. "If $1 = 1$, then $2 = 3$." **FALSE**
3. "If $1 = 0$, then $3 = 3$." **TRUE**
4. "If $1 = 2$, then $2 = 3$." **TRUE**
5. "If $1 = 1$, then $1 = 2$ and $2 = 3$." **FALSE**
6. "If $1 = 3$ or $1 = 2$ then $3 = 3$." **TRUE**

ALTERNATIVE WAYS OF EXPRESSING IMPLICATIONS:

The implication **$p \rightarrow q$** could be expressed in many alternative ways as:

- "if p then q" • "not p unless q"
- "p implies q" • "q follows from p"
- "if p, q" • "q if p"
- "p only if q" • "q whenever p"
- "p is sufficient for q" • "q is necessary for p"

EXERCISE:

Write the following statements in the form "if p, then q" in English.

a) *Your guarantee is good only if you bought your CD less than 90 days ago.*

If your guarantee is good, then you must have bought your CD player less than 90 days ago.

b) *To get tenure as a professor, it is sufficient to be world-famous.*

If you are world-famous, then you will get tenure as a professor.

c) *That you get the job implies that you have the best credentials.*

If you get the job, then you have the best credentials.

d) *It is necessary to walk 8 miles to get to the top of the Peak.*

If you get to the top of the peak, then you must have walked 8 miles.

TRANSLATING ENGLISH SENTENCES TO SYMBOLS:

Let p and q be propositions:

p = "you get an A on the final exam"

q = "you do every exercise in this book"

r = "you get an A in this class"

Write the following propositions using p , q , and r and logical connectives.

1. To get an A in this class it is necessary for you to get an A on the final.

SOLUTION $p \rightarrow r$

2. You do every exercise in this book; You get an A on the final, implies, you get an A in the class.

SOLUTION $p \wedge q \rightarrow r$

3. Getting an A on the final and doing every exercise in this book is sufficient for getting an A in this class.

SOLUTION $p \wedge q \rightarrow r$

TRANSLATING SYMBOLIC PROPOSITIONS TO ENGLISH:

Let p , q , and r be the propositions:

p = "you have the flu"

q = "you miss the final exam"

r = "you pass the course"

Express the following propositions as an English sentence.

1. $p \rightarrow q$

If you have flu, then you will miss the final exam.

2. $\sim q \rightarrow r$

If you don't miss the final exam, you will pass the course.

3. $\sim p \wedge \sim q \rightarrow r$

If you neither have flu nor miss the final exam, then you will pass the course.

HIERARCHY OF OPERATIONS

FOR LOGICAL CONNECTIVES

\sim (negation)

\wedge (conjunction), \vee (disjunction)

\rightarrow (conditional)

Construct a truth table for the statement form $p \vee \sim q \rightarrow \sim p$

p	q	$\sim q$	$\sim p$	$p \vee \sim q$	$p \vee \sim q \rightarrow \sim p$
T	T	F	F	T	F
T	F	T	F	T	F
F	T	F	T	F	T
F	F	T	T	T	T

Construct a truth table for the statement form $(p \rightarrow q) \wedge (\sim p \rightarrow r)$

p	q	r	$p \rightarrow q$	$\sim p$	$\sim p \rightarrow r$	$(p \rightarrow q) \wedge (\sim p \rightarrow r)$
T	T	T	T	F	T	T
T	T	F	T	F	T	T
T	F	T	F	F	T	F
T	F	F	F	F	T	F
F	T	T	T	T	T	T
F	T	F	T	T	F	F
F	F	T	T	T	T	T
F	F	F	T	T	F	F

LOGICAL EQUIVALENCE INVOLVING IMPLICATION

Use truth table to show $p \rightarrow q \equiv \sim q \rightarrow \sim p$

p	q	$\sim q$	$\sim p$	$p \rightarrow q$	$\sim q \rightarrow \sim p$
T	T	F	F	T	T
T	F	T	F	F	F
F	T	F	T	T	T
F	F	T	T	T	T

same truth values

Hence the given two expressions are equivalent.

IMPLICATION LAW

$p \rightarrow q \equiv \sim p \vee q$

p	q	$p \rightarrow q$	$\sim p$	$\sim p \vee q$
T	T	T	F	T
T	F	F	F	F
F	T	T	T	T
F	F	T	T	T

same truth values

NEGATION OF A CONDITIONAL STATEMENT:Since $p \rightarrow q \equiv \sim p \vee q$ therefore

$$\begin{aligned} \sim(p \rightarrow q) &\equiv \sim(\sim p \vee q) \\ &\equiv \sim(\sim p) \wedge (\sim q) \text{ by De Morgan's law} \\ &\equiv p \wedge \sim q \text{ by the Double Negative law} \end{aligned}$$

Thus the negation of “**if p then q**” is logically equivalent to “**p and not q**”.

Accordingly, the negation of an if-then statement does not start with the word if.

EXAMPLES**Write negations of each of the following statements:**

1. If Ali lives in Pakistan then he lives in Lahore.
2. If my car is in the repair shop, then I cannot get to class.
3. If x is prime then x is odd **or** x is 2.
4. If n is divisible by 6, then n is divisible by 2 **and** n is divisible by 3.

SOLUTIONS:

1. Ali lives in Pakistan and he does not live in Lahore.
2. My car is in the repair shop and I can get to class.
3. x is prime but x is not odd **and** x is not 2.
4. n is divisible by 6 but n is not divisible by 2 **or** by 3.

INVERSE OF A CONDITIONAL STATEMENT:The inverse of the conditional statement $p \rightarrow q$ is $\sim p \rightarrow \sim q$

A conditional and its inverse are not equivalent as could be seen from the truth table.

p	q	$p \rightarrow q$	$\sim p$	$\sim q$	$\sim p \rightarrow \sim q$
T	T	T	F	F	T
T	F	F	F	T	T
F	T	T	T	F	F
F	F	T	T	T	T



different truth values in rows 2 and 3

WRITING INVERSE:

1. *If today is Friday, then $2 + 3 = 5$.*
If today is not Friday, then $2 + 3 \neq 5$.
2. *If it snows today, I will ski tomorrow.*
If it does not snow today I will not ski tomorrow.
3. *If P is a square, then P is a rectangle.*
If P is not a square then P is not a rectangle.
4. *If my car is in the repair shop, then I cannot get to class.*
If my car is not in the repair shop, then I shall get to the class.

CONVERSE OF A CONDITIONAL STATEMENT:The converse of the conditional statement $p \rightarrow q$ is $q \rightarrow p$

A conditional and its converse are not equivalent.

i.e., \rightarrow is not a commutative operator.

p	q	$p \rightarrow q$	$q \rightarrow p$
T	T	T	T
T	F	F	T
F	T	T	F
F	F	T	T

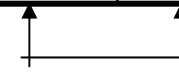
 not the same

WRITING CONVERSE:

1. *If today is Friday, then $2 + 3 = 5$.*

If $2 + 3 = 5$, then today is Friday.

2. *If it snows today, I will ski tomorrow.*

I will ski tomorrow only if it snows today.

3. *If P is a square, then P is a rectangle.*

If P is a rectangle then P is a square.

4. *If my car is in the repair shop, then I cannot get to class.*

If I cannot get to the class, then my car is in the repair shop.

CONTRAPOSITIVE OF A CONDITIONAL STATEMENT:

The contrapositive of the conditional statement $p \rightarrow q$ is $\sim q \rightarrow \sim p$

A conditional and its contrapositive are equivalent. Symbolically $p \rightarrow q \equiv \sim q \rightarrow \sim p$

1. *If today is Friday, then $2 + 3 = 5$.*

If $2 + 3 \neq 5$, then today is not Friday.

2. *If it snows today, I will ski tomorrow.*

I will not ski tomorrow only if it does not snow today.

3. *If P is a square, then P is a rectangle.*

If P is not a rectangle then P is not a square.

4. *If my car is in the repair shop, then I cannot get to class.*

If I get to the class, then my car is not in the repair shop.

Lecture No.4 Biconditional

BICONDITIONAL

If p and q are statement variables, the biconditional of p and q is “ p if, and only if, q ” and is denoted $p \leftrightarrow q$. *if and only if* abbreviated **iff**. The double headed arrow “ \leftrightarrow ” is the **biconditional operator**.
TRUTH TABLE FOR

$p \leftrightarrow q$.

p	q	$p \leftrightarrow q$
T	T	T
T	F	F
F	T	F
F	F	T

EXAMPLES:

True or false?

- “ $1+1 = 3$ if and only if earth is flat”
TRUE
- “Sky is blue iff $1 = 0$ ”
FALSE
- “Milk is white iff birds lay eggs”
TRUE
- “ 33 is divisible by 4 if and only if horse has four legs”
FALSE
- “ $x > 5$ iff $x^2 > 25$ ”
FALSE

$p \leftrightarrow q \equiv (p \rightarrow q) \wedge (q \rightarrow p)$

p	q	$p \leftrightarrow q$	$p \rightarrow q$	$q \rightarrow p$	$(p \rightarrow q) \wedge (q \rightarrow p)$
T	T	T	T	T	T
T	F	F	F	T	F
F	T	F	T	F	F
F	F	T	T	T	T



same truth values

REPHRASING BICONDITIONAL:

$p \leftrightarrow q$ is also expressed as:

“ p is necessary and sufficient for q ”

“if p then q, and conversely”

“p is equivalent to q”

EXERCISE:

Rephrase the following propositions in the form “p if and only if q” in English.

1. If it is hot outside you buy an ice cream cone, and if you buy an ice cream cone it is hot outside.

Sol You buy an ice cream cone if and only if it is hot outside.

2. For you to win the contest it is necessary and sufficient that you have the only winning ticket.

Sol You win the contest if and only if you hold the only winning ticket.

3. If you read the news paper every day, you will be informed and conversely.

Sol You will be informed if and only if you read the news paper every day.**4.It rains if it is a weekend day, and it is a weekend day if it rains.**

Sol It rains if and only if it is a weekend day.

5. The train runs late on exactly those days when I take it.

Sol The train runs late if and only if it is a day I take the train.

6. This number is divisible by 6 precisely when it is divisible by both 2 and 3.

Sol This number is divisible by 6 if and only if it is divisible by both 2 and 3.

TRUTH TABLE FOR

$$(p \rightarrow q) \leftrightarrow (\sim q \rightarrow \sim p)$$

p	q	$p \rightarrow q$	$\sim q$	$\sim p$	$\sim q \rightarrow \sim p$	$(p \rightarrow q) \leftrightarrow (\sim q \rightarrow \sim p)$
T	T	T	F	F	T	T
T	F	F	T	F	F	T
F	T	T	F	T	T	T
F	F	T	T	T	T	T

TRUTH TABLE FOR

$$(p \leftrightarrow q) \leftrightarrow (r \leftrightarrow q)$$

p	q	r	$p \leftrightarrow q$	$r \leftrightarrow q$	$(p \leftrightarrow q) \leftrightarrow (r \leftrightarrow q)$
T	T	T	T	T	T
T	T	F	T	F	F
T	F	T	F	F	T
T	F	F	F	T	F
F	T	T	F	T	F
F	T	F	F	F	T
F	F	T	T	F	F
F	F	F	T	T	T

TRUTH TABLE FOR

$$p \wedge \sim r \leftrightarrow q \vee r$$

Here $p \wedge \sim r \leftrightarrow q \vee r$ means $(p \wedge (\sim r)) \leftrightarrow (q \vee r)$

p	q	r	$\sim r$	$p \wedge \sim r$	$q \vee r$	$p \wedge \sim r \leftrightarrow q \vee r$
T	T	T	F	F	T	F
T	T	F	T	T	T	T
T	F	T	F	F	T	F
T	F	F	T	T	F	F
F	T	T	F	F	T	F
F	T	F	T	F	T	F
F	F	T	F	F	T	F
F	F	F	T	F	F	T

LOGICAL EQUIVALENCE**INVOLVING BICONDITIONAL**

Show that $\sim p \leftrightarrow q$ and $p \leftrightarrow \sim q$ are logically equivalent

p	q	$\sim p$	$\sim q$	$\sim p \leftrightarrow q$	$p \leftrightarrow \sim q$
T	T	F	F	F	F
T	F	F	T	T	T
F	T	T	F	T	T
F	F	T	T	F	F



same truth values

EXERCISE:

Show that $\sim(p \oplus q)$ and $p \leftrightarrow q$ are logically equivalent

p	q	$p \oplus q$	$\sim(p \oplus q)$	$p \leftrightarrow q$
T	T	F	T	T
T	F	T	F	F
F	T	T	F	F
F	F	F	T	T

↑—————↑
same truth values

LAWS OF LOGIC:

1. Commutative Law: $p \leftrightarrow q \equiv q \leftrightarrow p$
2. Implication Laws: $p \rightarrow q \equiv \sim p \vee q$
 $\equiv \sim(p \wedge \sim q)$
3. Exportation Law: $(p \wedge q) \rightarrow r \equiv p \rightarrow (q \rightarrow r)$
4. Equivalence: $p \leftrightarrow q \equiv (p \rightarrow q) \wedge (q \rightarrow p)$
5. Reductio ad absurdum $p \rightarrow q \equiv (p \wedge \sim q) \rightarrow c$

APPLICATION:

Rewrite the statement forms without using the symbols \rightarrow or \leftrightarrow

1. $p \wedge \sim q \rightarrow r$
2. $(p \rightarrow r) \leftrightarrow (q \rightarrow r)$

SOLUTION

1. $p \wedge \sim q \rightarrow r \equiv (p \wedge \sim q) \rightarrow r$ order of operations
 $\equiv \sim(p \wedge \sim q) \vee r$ implication law
2. $(p \rightarrow r) \leftrightarrow (q \rightarrow r) \equiv (\sim p \vee r) \leftrightarrow (\sim q \vee r)$ implication law
 $\equiv [(\sim p \vee r) \rightarrow (\sim q \vee r)] \wedge [(\sim q \vee r) \rightarrow (\sim p \vee r)]$ equivalence of biconditional
 $\equiv [\sim(\sim p \vee r) \vee (\sim q \vee r)] \wedge [\sim(\sim q \vee r) \vee (\sim p \vee r)]$ implication law

Rewrite the statement form $\sim p \vee q \rightarrow r \vee \sim q$ to a logically equivalent form that uses only \sim and \wedge

SOLUTION**STATEMENT****REASON**

- | | |
|---|--|
| $\sim p \vee q \rightarrow r \vee \sim q$ | Given statement form |
| $\equiv (\sim p \vee q) \rightarrow (r \vee \sim q)$ | Order of operations |
| $\equiv \sim[(\sim p \vee q) \wedge \sim(r \vee \sim q)]$ | Implication law $p \rightarrow q \equiv \sim(p \wedge \sim q)$ |
| $\equiv \sim[\sim(p \wedge \sim q) \wedge (\sim r \wedge q)]$ | De Morgan's law |

Show that $\sim(p \rightarrow q) \rightarrow p$ is a tautology without using truth tables.

SOLUTION

STATEMENT	REASON
$\sim(p \rightarrow q) \rightarrow p$	Given statement form
$\equiv \sim[\sim(p \wedge \sim q)] \rightarrow p$	Implication law $p \rightarrow q \equiv \sim(p \wedge \sim q)$
$\equiv (p \wedge \sim q) \rightarrow p$	Double negation law
$\equiv \sim(p \wedge \sim q) \vee p$	Implication law $p \rightarrow q \equiv \sim p \vee q$
$\equiv (\sim p \vee q) \vee p$	De Morgan's law
$\equiv (q \vee \sim p) \vee p$	Commutative law of
$\vee \equiv q \vee (\sim p \vee p)$	Associative law of
$\vee \equiv q \vee t$	Negation law
$\equiv t$	Universal bound law

EXERCISE:

Suppose that p and q are statements so that $p \rightarrow q$ is false. Find the truth values of each of the following:

1. $\sim p \rightarrow q$
2. $p \vee q$
3. $q \leftrightarrow p$

SOLUTION

1. TRUE
2. TRUE
3. FALSE

Lecture No.5 Argument

EXAMPLE

An interesting teacher keeps me awake. I stay awake in Discrete Mathematics class.
Therefore, my Discrete Mathematics teacher is interesting.

Is the above argument valid?

ARGUMENT:

An **argument** is a list of statements called **premises** (or **assumptions** or **hypotheses**) followed by a statement called the **conclusion**.

P₁ Premise

P₂ Premise

P₃ Premise

.....

P_n Premise

∴ C Conclusion

NOTE The symbol ∴ read “therefore,” is normally placed just before the conclusion.

VALID AND INVALID ARGUMENT:

An argument is **valid** if the conclusion is true when all the premises are true.

Alternatively, an argument is valid if conjunction of its premises imply conclusion. That is $(P_1 \wedge P_2 \wedge P_3 \wedge \dots \wedge P_n) \rightarrow C$ is a tautology.

An argument is **invalid** if the conclusion is false when all the premises are true.

Alternatively, an argument is invalid if conjunction of its premises does not imply conclusion.

EXAMPLE:

Show that the following argument form is valid:

$$\begin{array}{l} p \rightarrow q \\ p \\ \therefore q \end{array}$$

SOLUTION

premises	conclusion
↓	↓
↓	↓

p	q	$p \rightarrow q$	p	q
T	T	T	T	T
T	F	F	T	F
F	T	T	F	T
F	F	T	F	F

← critical row

EXAMPLE Show that the following argument form is invalid:

$$\begin{array}{l} p \rightarrow q \\ q \\ \therefore p \end{array}$$

SOLUTION

p	q	$p \rightarrow q$	q	p
T	T	T	T	T
T	F	F	F	T
F	T	T	T	F
F	F	T	F	F

premisses
conclusion

critical row

EXERCISE:

Use truth table to determine the argument form

$$\begin{aligned}
 & p \vee q \\
 & p \rightarrow \sim q \\
 & p \rightarrow r \\
 & \therefore r
 \end{aligned}$$

is valid or invalid.

p	q	r	$p \vee q$	$p \rightarrow \sim q$	$p \rightarrow r$	r
T	T	T	T	F	T	T
T	T	F	T	F	F	F
T	F	T	T	T	T	T
T	F	F	T	T	F	F
F	T	T	T	T	T	T
F	T	F	T	T	T	F
F	F	T	F	T	T	T
F	F	F	F	T	T	F

premisses
conclusion

Critical rows

The argument form is invalid

WORD PROBLEM

If Tariq is not on team A, then Hameed is on team B.

If Hameed is not on team B, then Tariq is on team A.

\therefore Tariq is not on team A or Hameed is not on team B.

SOLUTION

Let

t = Tariq is on team A

h = Hameed is on team B

Then the argument is

$\sim t \rightarrow h$

$\sim h \rightarrow t$

$\therefore \sim t \vee \sim h$

t	h	$\sim t \rightarrow h$	$\sim h \rightarrow t$	$\sim t \vee \sim h$
T	T	T	T	F
T	F	T	T	T
F	T	T	T	T
F	F	F	F	T

Argument is invalid. Because there are three critical rows (Remember that the critical rows are those rows where the premises have truth value T) and in the first critical row conclusion has truth value F. (Also remember that we say an argument is valid if in all critical rows conclusion has truth value T)

EXERCISE

If at least one of these two numbers is divisible by 6, then the product of these two numbers is divisible by 6.

Neither of these two numbers is divisible by 6.

\therefore The product of these two numbers is not divisible by 6.

SOLUTION

Let d = at least one of these two numbers is divisible by 6.

p = product of these two numbers is divisible by 6.

Then the argument become in these symbols

$d \rightarrow p$

$\sim d$

$\therefore \sim p$

We will made the truth table for premises and conclusion as given below

d	p	$d \rightarrow p$	$\sim d$	$\sim p$
T	T	T	F	F
T	F	F	F	T
F	T	T	T	F
F	F	T	T	T

The Argument is invalid.

EXERCISE

If I got an Eid bonus, I'll buy a stereo.

If I sell my motorcycle, I'll buy a stereo.

\therefore If I get an Eid bonus or I sell my motorcycle, then I'll buy a stereo.

SOLUTION:

Let

e = I got an Eid bonus

s = I'll buy a stereo

m = I sell my motorcycle

The argument is

$e \rightarrow s$

$m \rightarrow s$

$\therefore e \vee m \rightarrow s$

e	s	m	$e \rightarrow s$	$m \rightarrow s$	$e \vee m$	$e \vee m \rightarrow s$
T	T	T	T	T	T	T
T	T	F	T	T	T	T
T	F	T	F	F	T	F
T	F	F	F	T	T	F
F	T	T	T	T	T	T
F	T	F	T	T	F	T
F	F	T	T	F	T	F
F	F	F	T	T	F	T

The argument is valid. Because there are five critical rows

(Remember that the critical rows are those rows where the premises have truth value T) and in all critical row conclusion has truth value T. (Also remember that we say an argument is valid if in all critical rows conclusion has truth value T)

EXERCISE

An interesting teacher keeps me awake. I stay awake in Discrete Mathematics class.

Therefore, my Discrete Mathematics teacher is interesting.

Solution: t : my teacher is interesting a : I stay awake

m : I am in Discrete Mathematics class the argument to be tested is

$t \rightarrow a,$

$a \wedge m$

Therefore $m \wedge t$

t	a	m	$t \rightarrow a$	$a \wedge m$	$m \wedge t$
T	T	T	T	T	T
T	T	F	T	F	F
T	F	T	F	F	T
T	F	F	F	F	F
F	T	T	T	T	F
F	T	F	T	F	F
F	F	T	T	F	F
F	F	F	T	F	F

Argument is not valid

Lecture No.6

Applications of logic

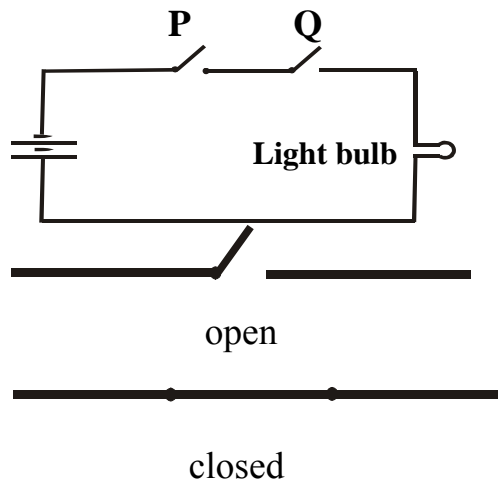
SWITCHES IN SERIES

Switches		Light Bulb
P	Q	State
Closed	Closed	On
Closed	Open	Off
Open	Closed	Off
Open	Open	Off

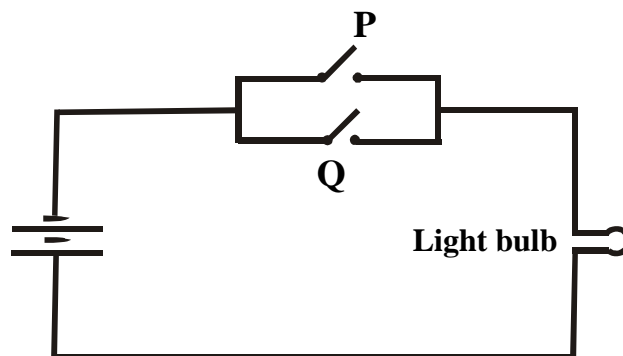
SWITCHES IN PARALLEL:

Switches		Light Bulb
P	Q	State
Closed	Closed	On
Closed	Open	On
Open	Closed	On
Open	Open	Off

SWITCHES IN SERIES:

Switches		Light Bulb
P	Q	State
Closed	Closed	On
Closed	Open	Off
Open	Closed	Off
Open	Open	Off

P	Q	$P \wedge Q$
T	T	T
T	F	F
F	T	F
F	F	F

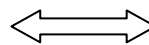

SWITCHES IN PARALLEL:

Switches		Light Bulb
P	Q	State
Closed	Closed	On
Closed	Open	On
Open	Closed	On
Open	Open	Off

P	Q	$P \vee Q$
T	T	T
T	F	T
F	T	T
F	F	F

1.NOT-gate

A NOT-gate (or inverter) is a circuit with one input and one output signal. If the input signal is 1, the output signal is 0. Conversely, if the input signal is 0, then the output signal is 1.

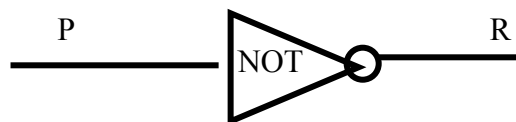

Input	Output
P	R
1	0
0	1

2.AND-gate

An AND-gate is a circuit with two input signals and one output signal. If both input signals are 1, the output signal is 1. Otherwise the output signal is 0. Symbolic representation & Input/Output Table

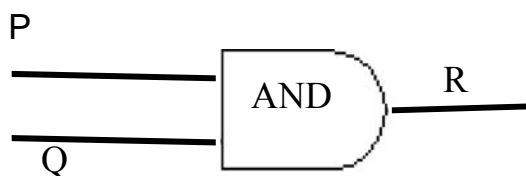

Input		Output
P	Q	R
1	1	1
1	0	0
0	1	0
0	0	0

3. OR-gate

An OR-gate is a circuit with two input signals and one output signal.

If both input signals are 0, then the output signal is 0. Otherwise, the output signal is 1.

Symbolic representation & Input/Output Table

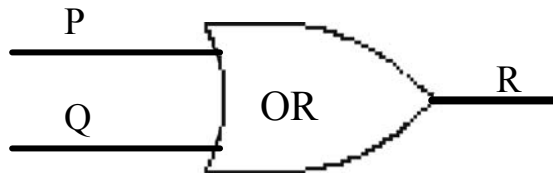

Input		Output
P	Q	R
1	1	1
1	0	1
0	1	1
0	0	0

COMBINATIONAL CIRCUIT:

A Combinational Circuit is a compound circuit consisting of the basic logic gates such as NOT, AND, OR.

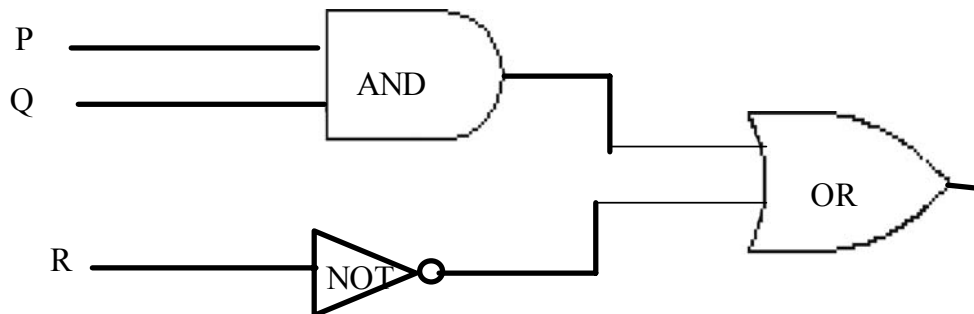

DETERMINING OUTPUT FOR A GIVEN INPUT:

Indicate the output of the circuit below when the input signals are $P = 1$, $Q = 0$ and $R = 0$

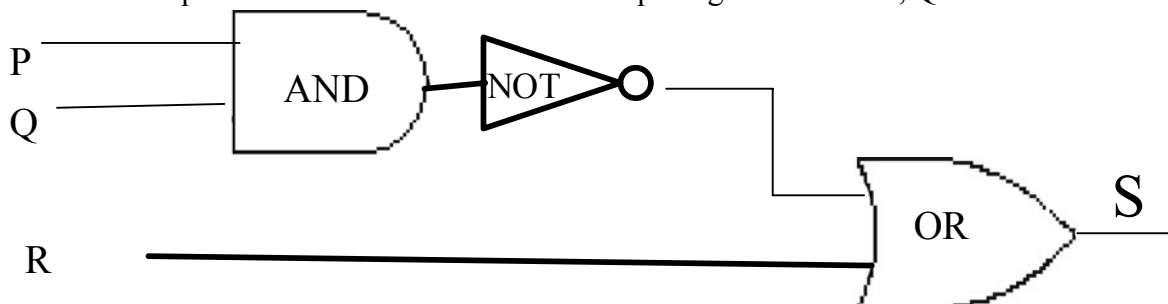

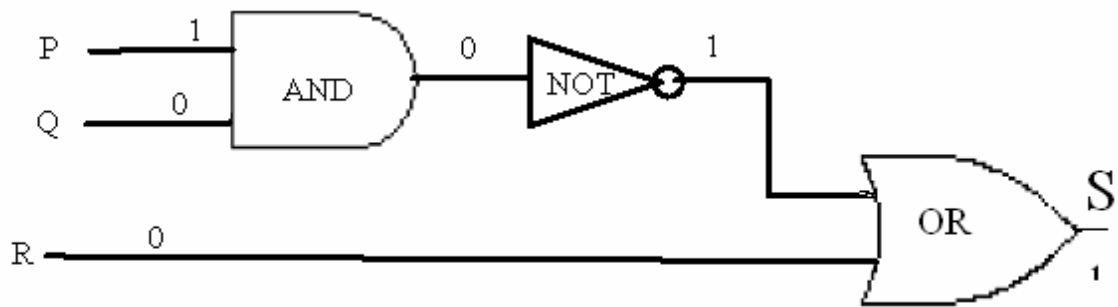
SOLUTION:**Output S = 1****CONSTRUCTING THE INPUT/OUTPUT TABLE FOR A CIRCUIT**

Construct the input/output table for the following circuit.

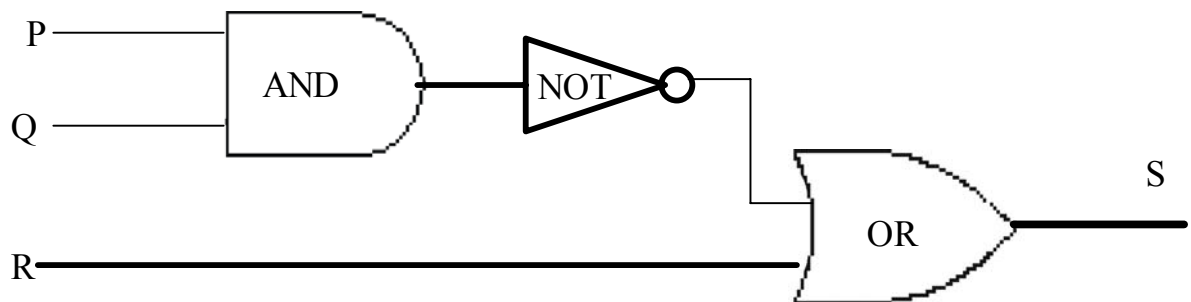
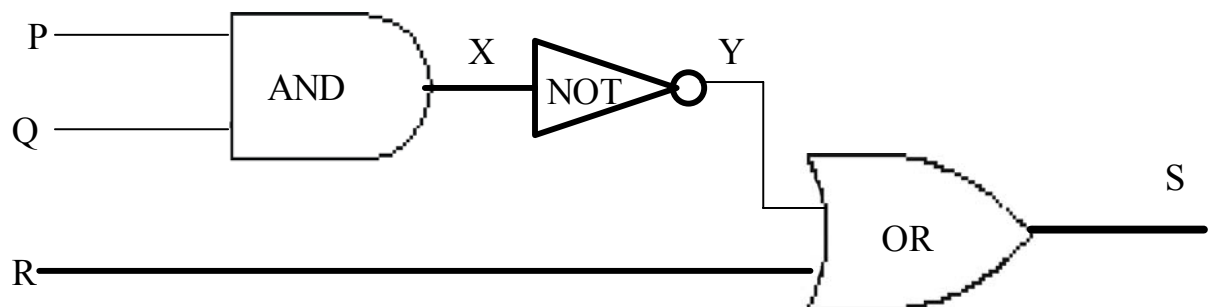
**LABELING INTERMEDIATE OUTPUTS:**

P	Q	R	X	Y	S
1	1	1	1	0	1
1	1	0	1	0	0
1	0	1	0	1	1
1	0	0	0	1	1
0	1	1	0	1	1
0	1	0	0	1	1
0	0	1	0	1	1
0	0	0	0	1	1

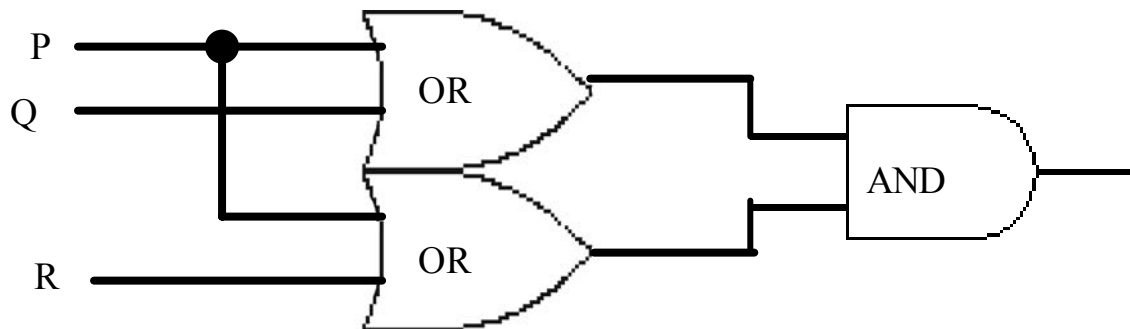
FINDING A BOOLEAN EXPRESSION FOR A CIRCUIT**SOLUTION:**

Trace through the circuit from left to right, writing down the output of each logic gate.

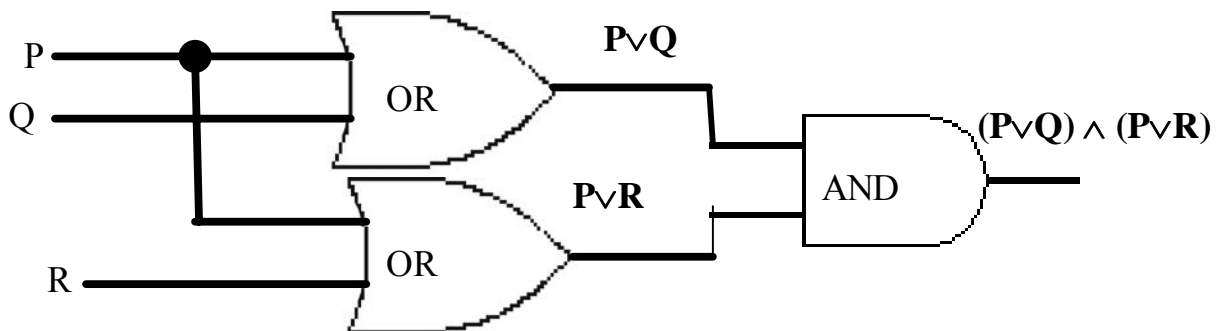

Hence $(P \vee Q) \wedge (P \vee R)$ is the Boolean expression for this circuit.

CIRCUIT CORRESPONDING TO A BOOLEAN EXPRESSION**EXERCISE**

Construct circuit for the Boolean expression $(P \wedge Q) \vee \sim R$

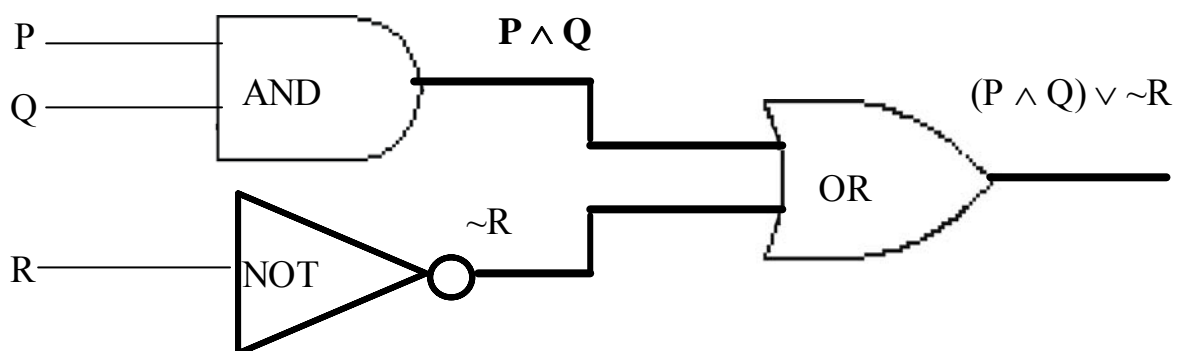
SOLUTION

CIRCUIT FOR INPUT/OUTPUT TABLE:

INPUTS			OUTPU
P	Q	R	S
1	1	1	0
1	1	0	1
1	0	1	0
1	0	0	0
0	1	1	1
0	1	0	0
0	0	1	0
0	0	0	0

SOLUTION:

INPUTS			OUTPUT	
P	Q	R	S	
1	1	1	0	
1	1	0	1	→ $P \wedge Q \wedge \sim R$
1	0	1	0	
1	0	0	0	
0	1	1	1	→ $\sim P \wedge Q \wedge R$
0	1	0	0	
0	0	1	0	
0	0	0	0	

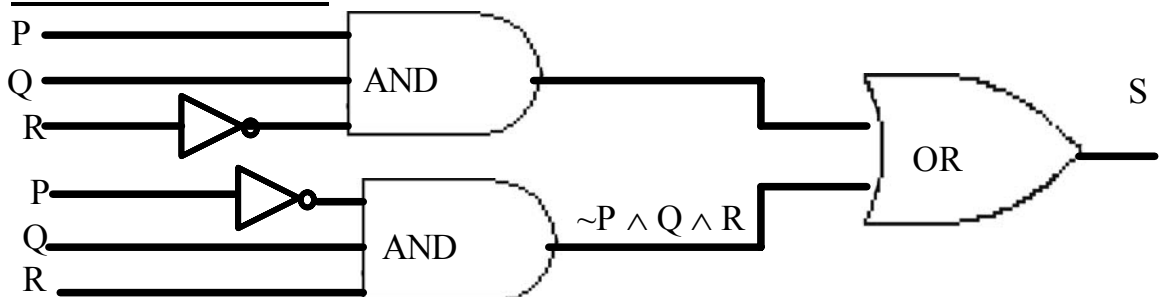
CIRCUIT DIAGRAM:

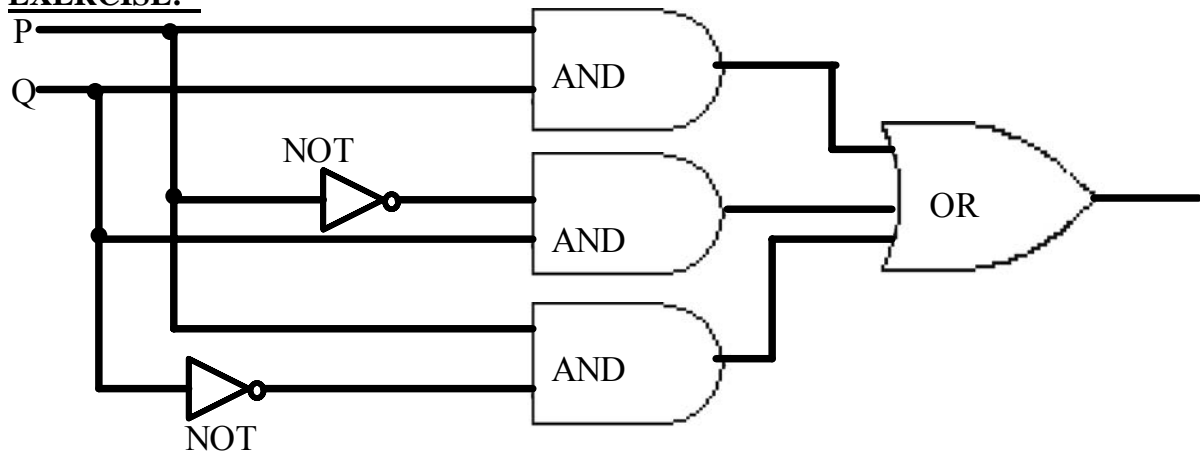
EXERCISE:**SOLUTION:**

We find the Boolean expressions for the circuits and show that they are logically equivalent, when regarded as statement forms.

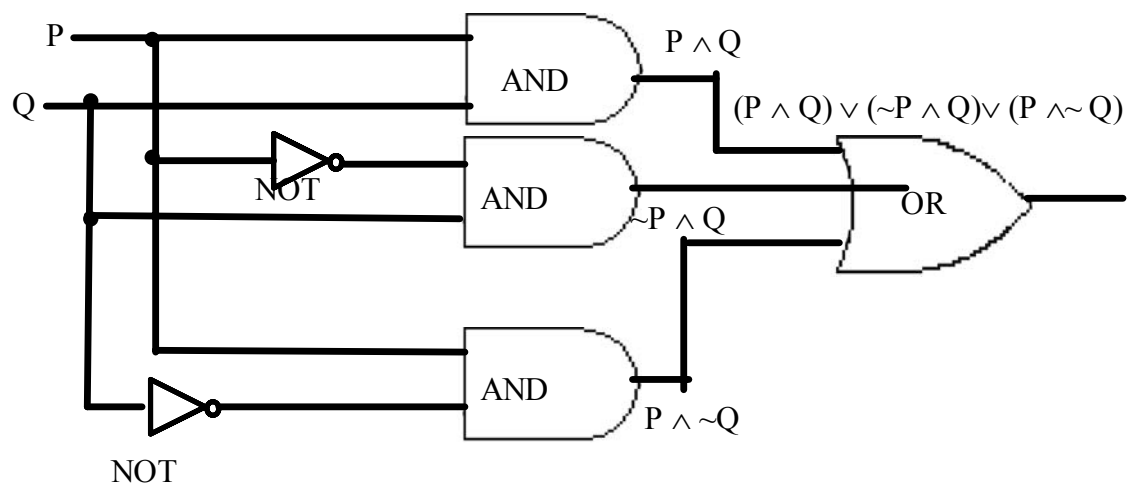
**STATEMENT**

$$\begin{aligned}
 & (P \wedge Q) \vee (\sim P \wedge Q) \wedge (P \wedge \sim Q) \\
 \equiv & (P \wedge Q) \wedge (\sim P \wedge Q) \wedge (P \wedge \sim Q) \\
 \equiv & (P \wedge \sim P) \wedge Q \wedge (P \wedge \sim Q) \\
 \equiv & t \wedge Q \wedge (P \wedge \sim Q) \\
 \equiv & Q \wedge (P \wedge \sim Q) \\
 \equiv & (Q \wedge P) \wedge (Q \wedge \sim Q) \\
 \equiv & (Q \wedge P) \wedge t \\
 \equiv & (Q \vee P) \vee t \\
 \equiv & Q \vee P \\
 \equiv & P \vee Q
 \end{aligned}$$

Thus $(P \wedge Q) \wedge (\sim P \wedge Q) \wedge (P \wedge \sim Q) \equiv P \wedge Q$

Accordingly, the two circuits are equivalent

REASON

Distributive law

Negation law

Identity law

Distributive law

Negation law

identity law

Commutative law

Lecture No.7 Set theory

A well defined collection of {distinct} objects is called a set.

- The objects are called the elements or members of the set.
- Sets are denoted by capital letters A, B, C ..., X, Y, Z.
- The elements of a set are represented by lower case letters a, b, c, ... , x, y, z.
- If an object x is a member of a set A we write $x \in A$, which reads "x belongs to A" or "x is in A" or "x is an element of A", otherwise we write $x \notin A$, which reads "x does not belong to A" or "x is not in A" or "x is not an element of A".

TABULAR FORM

Listing all the elements of a set, separated by commas and enclosed within braces or curly brackets {}.

EXAMPLES

In the following examples we write the sets in Tabular Form.

$A = \{1, 2, 3, 4, 5\}$ is the set of first five **Natural Numbers**.

$B = \{2, 4, 6, 8, \dots, 50\}$ is the set of **Even numbers** up to 50.

$C = \{1, 3, 5, 7, 9, \dots\}$ is the set of **positive odd numbers**.

NOTE

The symbol "... " is called an ellipsis. It is a short for "and so forth."

DESCRIPTIVE FORM:

Stating in words the elements of a set.

EXAMPLES

Now we will write the same examples which we write in Tabular Form, in the Descriptive Form.

A = set of first five Natural Numbers. (is the Descriptive Form)

B = set of positive even integers less or equal to fifty.

(is the Descriptive Form)

$C = \{1, 3, 5, 7, 9, \dots\}$ (is the Descriptive Form)

C = set of positive odd integers. (is the Descriptive Form)

SET BUILDER FORM:

Writing in symbolic form the common characteristics shared by all the elements of the set.

EXAMPLES:

Now we will write the same examples which we write in Tabular as well as Descriptive Form, in Set Builder Form .

$A = \{x \in \mathbb{N} / x \leq 5\}$ (is the Set Builder Form)

$B = \{x \in \mathbb{E} / 0 < x \leq 50\}$ (is the Set Builder Form)

$C = \{x \in \mathbb{O} / 0 < x \}$ (is the Set Builder Form)

SETS OF NUMBERS:

1. Set of Natural Numbers

$N = \{1, 2, 3, \dots\}$

2. Set of Whole Numbers

$W = \{0, 1, 2, 3, \dots\}$

3. Set of Integers

$$Z = \{\dots, -3, -2, -1, 0, +1, +2, +3, \dots\}$$

$$= \{0, \pm 1, \pm 2, \pm 3, \dots\}$$

{“Z” stands for the first letter of the German word for integer: Zahlen.}

4. Set of Even Integers

$$E = \{0, \pm 2, \pm 4, \pm 6, \dots\}$$

5. Set of Odd Integers

$$O = \{\pm 1, \pm 3, \pm 5, \dots\}$$

6. Set of Prime Numbers

$$P = \{2, 3, 5, 7, 11, 13, 17, 19, \dots\}$$

7. Set of Rational Numbers (or Quotient of Integers)

$$Q = \{x \mid x = \frac{p}{q}; p, q \in \mathbb{Z}, q \neq 0\}$$

8. Set of Irrational Numbers

$$\bar{Q} = Q' = \{x \mid x \text{ is not rational}\}$$

For example, $\sqrt{2}$, $\sqrt{3}$, π , e , etc.

9. Set of Real Numbers

$$R = Q \cup Q'$$

10. Set of Complex Numbers

$$C = \{z \mid z = x + iy; x, y \in \mathbb{R}\}$$

SUBSET:

If A & B are two sets, A is called a subset of B, written $A \subseteq B$, if, and only if, any element of A is also an element of B.

Symbolically:

$$A \subseteq B \Leftrightarrow \text{if } x \in A \text{ then } x \in B$$

REMARK:

1. When $A \subseteq B$, then B is called a superset of A.
2. When A is not subset of B, then there exist at least one $x \in A$ such that $x \notin B$.
3. Every set is a subset of itself.

EXAMPLES:

Let

$$A = \{1, 3, 5\} \quad B = \{1, 2, 3, 4, 5\}$$

$$C = \{1, 2, 3, 4\} \quad D = \{3, 1, 5\}$$

Then

$A \subseteq B$ (Because every element of A is in B)

$C \subseteq B$ (Because every element of C is also an element of B)

$A \subseteq D$ (Because every element of A is also an element of D and also note that every element of D is in A so $D \subseteq A$)

and A is not subset of C .

(Because there is an element 5 of A which is not in C)

EXAMPLE:

The set of integers “Z” is a subset of the set of Rational Number “Q”, since every integer ‘n’ could be written as:

$$n = \frac{n}{1} \in Q$$

Hence $Z \subseteq Q$.

PROPER SUBSET:

Let A and B be sets. A is a proper subset of B, if, and only if, every element of A is in B but there is at least one element of B that is not in A, and is denoted as $A \subset B$.

EXAMPLE:

$$\text{Let } A = \{1, 3, 5\} \quad B = \{1, 2, 3, 5\}$$

then $A \subset B$ (Because there is an element 2 of B which is not in A).

EQUAL SETS:

Two sets A and B are equal if, and only if, every element of A is in B and every element of B is in A and is denoted $A = B$.

Symbolically:

$$A = B \text{ iff } A \subseteq B \text{ and } B \subseteq A$$

EXAMPLE:

$$\begin{aligned} \text{Let } A &= \{1, 2, 3, 6\} & B &= \text{the set of positive divisors of 6} \\ C &= \{3, 1, 6, 2\} & D &= \{1, 2, 2, 3, 6, 6, 6\} \end{aligned}$$

Then A, B, C, and D are all equal sets.

NULL SET:

A set which contains no element is called a **null set**, or an **empty set** or a **void set**. It is denoted by the Greek letter \emptyset (phi) or $\{ \}$.

EXAMPLE

$A = \{x \mid x \text{ is a person taller than 10 feet}\} = \emptyset$ (Because there does not exist any human being which is taller then 10 feet)

$B = \{x \mid x^2 = 4, x \text{ is odd}\} = \emptyset$ (Because we know that there does not exist any odd whose square is 4)

REMARK

\emptyset is regarded as a subset of every set.

EXERCISE:

Determine whether each of the following statements is true or false.

a. $x \in \{x\}$

TRUE

(Because x is the member of the singleton set $\{x\}$)

b. $\{x\} \subseteq \{x\}$

TRUE

(Because Every set is the subset of itself.

Note that every Set has necessarily two subsets \emptyset and the Set itself, these two subset are known as Improper subsets and any other subset is called Proper Subset)

c. $\{x\} \in \{x\}$

FALSE

(Because $\{x\}$ is not the member of $\{x\}$) Similarly other

d. $\{x\} \in \{\{x\}\}$

TRUE

e. $\emptyset \subseteq \{x\}$

TRUE

f. $\emptyset \in \{x\}$

FALSE

UNIVERSAL SET:

The set of all elements under consideration is called the Universal Set.
The Universal Set is usually denoted by U .

VENN DIAGRAM:

A Venn diagram is a graphical representation of sets by regions in the plane.
The Universal Set is represented by the interior of a rectangle, and the other sets are represented by disks lying within the rectangle.

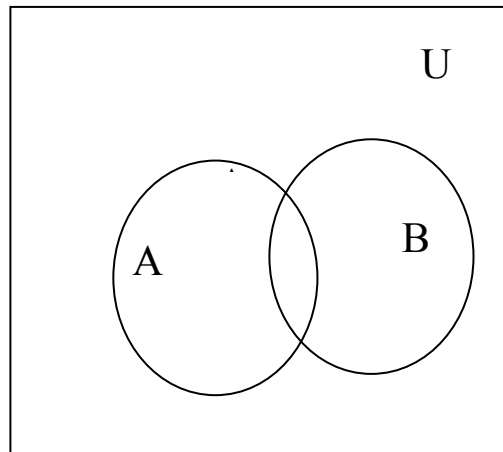
**FINITE AND INFINITE SETS:**

A set S is said to be **finite** if it contains exactly m distinct elements where m denotes some non negative integer.

In such case we write $|S| = m$ or $n(S) = m$

A set is said to be **infinite** if it is not finite.

EXAMPLES:

1. The set S of letters of English alphabets is finite and $|S| = 26$
2. The null set \emptyset has no elements, is finite and $|\emptyset| = 0$
3. The set of positive integers $\{1, 2, 3, \dots\}$ is infinite.

EXERCISE:

Determine which of the following sets are finite/infinite.

- | | |
|---|-----------------|
| 1. $A = \{\text{month in the year}\}$ | FINITE |
| 2. $B = \{\text{even integers}\}$ | INFINITE |
| 3. $C = \{\text{positive integers less than 1}\}$ | FINITE |
| 4. $D = \{\text{animals living on the earth}\}$ | FINITE |
| 5. $E = \{\text{lines parallel to x-axis}\}$ | INFINITE |
| 6. $F = \{x \in \mathbf{R} \mid x^{100} + 29x^{50} - 1 = 0\}$ | FINITE |
| 7. $G = \{\text{circles through origin}\}$ | INFINITE |

MEMBERSHIP TABLE:

A table displaying the membership of elements in sets. To indicate that an element is in a set, a 1 is used; to indicate that an element is not in a set, a 0 is used.

Membership tables can be used to prove set identities.

A	A^c
1	0
0	1

The above table is the Member ship table for Complement of A. now in the above table note that if an element is the member of A then it can't be the member of A^c thus where in the table we have 1 for A in that row we have 0 in A^c

Lecture No.8 Venn diagram

UNION:

Let A and B be subsets of a universal set U. The union of sets A and B is the set of all elements in U that belong to A or to B or to both, and is denoted $A \cup B$.

Symbolically:

$$A \cup B = \{x \in U \mid x \in A \text{ or } x \in B\}$$

EMAMPLE:

Let $U = \{a, b, c, d, e, f, g\}$

$A = \{a, c, e, g\}$, $B = \{d, e, f, g\}$

Then $A \cup B = \{x \in U \mid x \in A \text{ or } x \in B\}$
 $= \{a, c, d, e, f, g\}$

VENN DIAGRAM FOR UNION:

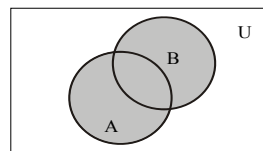

$A \cup B$ is shaded

REMARK:

1. $A \cup B = B \cup A$ that is union is commutative you can prove this very easily only by using definition.

2. $A \subseteq A \cup B$ and $B \subseteq A \cup B$

The above remark of subset is easily seen by the definition of union.

MEMBERSHIP TABLE FOR UNION:

A	B	$A \cup B$
1	1	1
1	0	1
0	1	1
0	0	0

REMARK:

This membership table is similar to the truth table for logical connective, disjunction (\vee).

INTERSECTION:

Let A and B subsets of a universal set U. The intersection of sets

A and B is the set of all elements in U that belong to both A and B and is denoted

$A \cap B$.

Symbolically:

$$A \cap B = \{x \in U \mid x \in A \text{ and } x \in B\}$$

EXMAPLE:

Let $U = \{a, b, c, d, e, f, g\}$
 $A = \{a, c, e, g\}$, $B = \{d, e, f, g\}$
 Then $A \cap B = \{e, g\}$

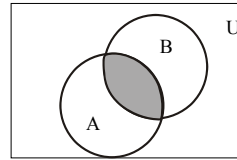

A ∩ B is shaded

VENN DIAGRAM FOR INTERSECTION:**REMARK:**

1. $A \cap B = B \cap A$
2. $A \cap B \subseteq A$ and $A \cap B \subseteq B$
3. If $A \cap B = \phi$, then A & B are called disjoint sets.

MEMBERSHIP TABLE FOR INTERSECTION:

A	B	$A \cap B$
1	1	1
1	0	0
0	1	0
0	0	0

REMARK:

This membership table is similar to the truth table for logical connective, conjunction (\wedge).

DIFFERENCE:

Let A and B be subsets of a universal set U. The difference of "A and B" (or relative complement of B in A) is the set of all elements in U that belong to A but not to B, and is denoted $A - B$ or $A \setminus B$.

Symbolically:

$$A - B = \{x \in U \mid x \in A \text{ and } x \notin B\}$$

EXAMPLE:

Let $U = \{a, b, c, d, e, f, g\}$
 $A = \{a, c, e, g\}$, $B = \{d, e, f, g\}$
 Then $A - B = \{a, c\}$

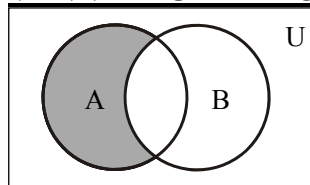
VENN DIAGRAM FOR SET DIFFERENCE:

A-B is shaded

REMARK:

1. $A - B \neq B - A$ that is set difference is not commutative.
2. $A - B \subseteq A$
3. $A - B, A \cap B$ and $B - A$ are mutually disjoint sets.

MEMBERSHIP TABLE FOR SET DIFFERENCE:

A	B	A - B
1	1	0
1	0	1
0	1	0
0	0	0

REMARK:

The membership table is similar to the truth table for $\sim(p \rightarrow q)$.

COMPLEMENT:

Let A be a subset of universal set U. The complement of A is the set of all element in U that do not belong to A, and is denoted A^c , \bar{A} or A^c

Symbolically:

$$A^c = \{x \in U \mid x \notin A\}$$

EXAMPLE:

Let $U = \{a, b, c, d, e, f, g\}$

$A = \{a, c, e, g\}$

Then $A^c = \{b, d, f\}$

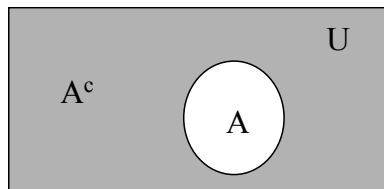
VENN DIAGRAM FOR COMPLEMENT:

A^c is shaded

REMARK :

1. $A^c = U - A$
2. $A \cap A^c = \phi$
3. $A \cup A^c = U$

MEMBERSHIP TABLE FOR COMPLEMENT:

A	A^c
1	0
0	1

REMARK

This membership table is similar to the truth table for logical connective negation (\sim)

EXERCISE:

Let $U = \{1, 2, 3, \dots, 10\}$, $X = \{1, 2, 3, 4, 5\}$

$Y = \{y \mid y = 2x, x \in X\}$, $Z = \{z \mid z^2 - 9z + 14 = 0\}$

Enumerate:

- | | | |
|----------------|-----------------|-----------------|
| (1) $X \cap Y$ | (2) $Y \cup Z$ | (3) $X - Z$ |
| (4) Y^c | (5) $X^c - Z^c$ | (6) $(X - Z)^c$ |

Firstly we enumerate the given sets.

Given

$$U = \{1, 2, 3, \dots, 10\},$$

$$X = \{1, 2, 3, 4, 5\}$$

$$Y = \{y \mid y = 2x, x \in X\} = \{2, 4, 6, 8, 10\}$$

$$Z = \{z \mid z^2 - 9z + 14 = 0\} = \{2, 7\}$$

- (1) $X \cap Y = \{1, 2, 3, 4, 5\} \cap \{2, 4, 6, 8, 10\}$
 $= \{2, 4\}$
- (2) $Y \cup Z = \{2, 4, 6, 8, 10\} \cup \{2, 7\}$
 $= \{2, 4, 6, 7, 8, 10\}$
- (3) $X - Z = \{1, 2, 3, 4, 5\} - \{2, 7\}$
 $= \{1, 3, 4, 5\}$
- (4) $Y^c = U - Y = \{1, 2, 3, \dots, 10\} - \{2, 4, 6, 8, 10\}$
 $= \{1, 3, 5, 7, 9\}$
- (5) $X^c - Z^c = \{6, 7, 8, 9, 10\} - \{1, 3, 4, 5, 6, 8, 9, 10\}$
 $= \{7\}$
- (6) $(X - Z)^c = U - (X - Z)$
 $= \{1, 2, 3, \dots, 10\} - \{1, 3, 4, 5\}$
 $= \{2, 6, 7, 8, 9, 10\}$

NOTE $(X - Z)^c \neq X^c - Z^c$

EXERCISE:

Given the following universal set U and its two subsets P and Q , where

$$U = \{x \mid x \in \mathbb{Z}, 0 \leq x \leq 10\}$$

$$P = \{x \mid x \text{ is a prime number}\}$$

$$Q = \{x \mid x^2 < 70\}$$

- (i) Draw a Venn diagram for the above
- (ii) List the elements in $P^c \cap Q$

SOLUTION:

First we write the sets in Tabular form.

$$U = \{x \mid x \in \mathbb{Z}, 0 \leq x \leq 10\}$$

Since it is the set of integers that are greater than or equal to 0 and less than or equal to 10. So we have

$$U = \{0, 1, 2, 3, \dots, 10\}$$

$$P = \{x \mid x \text{ is a prime number}\}$$

It is the set of prime numbers between 0 and 10. Remember Prime numbers are those numbers which have only two distinct divisors.

$$P = \{2, 3, 5, 7\}$$

$$Q = \{x \mid x^2 < 70\}$$

The set Q contains the elements between 0 and 10 which has their square less or equal to 70.

$$Q = \{0, 1, 2, 3, 4, 5, 6, 7, 8\}$$

Thus we write the sets in Tabular form.

VENN DIAGRAM:

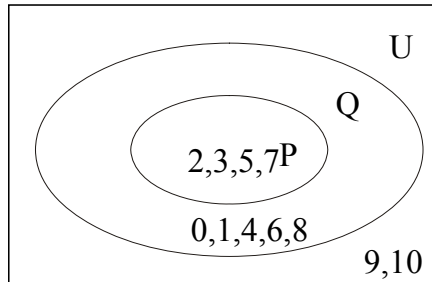

(i) $P^c \cap Q = ?$

$$\begin{aligned} P^c &= U - P = \{0, 1, 2, 3, \dots, 10\} - \{2, 3, 5, 7\} \\ &= \{0, 1, 4, 6, 8, 9, 10\} \end{aligned}$$

and

$$\begin{aligned} P^c \cap Q &= \{0, 1, 4, 6, 8, 9, 10\} \cap \{0, 1, 2, 3, 4, 5, 6, 7, 8\} \\ &= \{0, 1, 4, 6, 8\} \end{aligned}$$

EXERCISE:

Let

$$U = \{1, 2, 3, 4, 5\}, \quad C = \{1, 3\}$$

and A and B are non empty sets. Find A in each of the following:

- (i) $A \cup B = U$, $A \cap B = \phi$ and $B = \{1\}$
 (ii) $A \subset B$ and $A \cup B = \{4, 5\}$
 (iii) $A \cap B = \{3\}$, $A \cup B = \{2, 3, 4\}$ and $B \cup C = \{1, 2, 3\}$
 (iv) A and B are disjoint, B and C are disjoint, and the union of A and B is the set $\{1, 2\}$.

(i) $A \cup B = U$, $A \cap B = \phi$ and $B = \{1\}$

SOLUTION

$$\text{Since } A \cup B = U = \{1, 2, 3, 4, 5\}$$

$$\text{and } A \cap B = \phi,$$

$$\text{Therefore } A = B^c = \{1\}^c = \{2, 3, 4, 5\}$$

(i) $A \subset B$ and $A \cup B = \{4, 5\}$ also $C = \{1, 3\}$

SOLUTION

$$\text{When } A \subset B, \text{ then } A \cup B = B = \{4, 5\}$$

Also A being a proper subset of B implies

$$A = \{4\} \quad \text{or} \quad A = \{5\}$$

(iii) $A \cap B = \{3\}$, $A \cup B = \{2, 3, 4\}$ and $B \cup C = \{1, 2, 3\}$
 Also $C = \{1, 3\}$

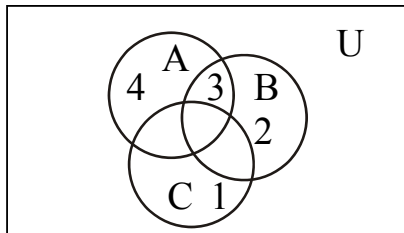
SOLUTION

Since we have 3 in the intersection of A and B as well as in C so we place 3 in common part shared by the three sets in the Venn diagram. Now since 1 is in the union of B and C it means that 1 may be in C or may be in B, but 1 cannot be in B because if 1 is in the B then it must be in $A \cup B$ but 1 is not there, thus we place 1 in the part of C which is not shared by any other set. Same is the reason for 4 and we place it in the set which is not shared by any other set. Now 2 will be in B, 2 cannot be in A because $A \cap B = \{3\}$, and is not in C. So $A = \{3, 4\}$ and $B = \{2, 3\}$

$$(i) \quad A \cap B = \phi, \quad B \cap C = \phi, \quad A \cup B = \{1, 2\}.$$

$$\text{Also } C = \{1, 3\}$$

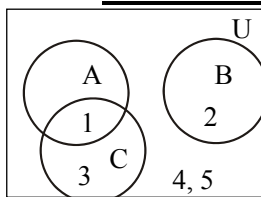
SOLUTION

$$A = \{1\}$$

EXERCISE:

Use a Venn diagram to represent the following:

- (i) $(A \cap B) \cap C^c$
- (ii) $A^c \cup (B \cup C)$
- (iii) $(A - B) \cap C$
- (iv) $(A \cap B^c) \cup C^c$

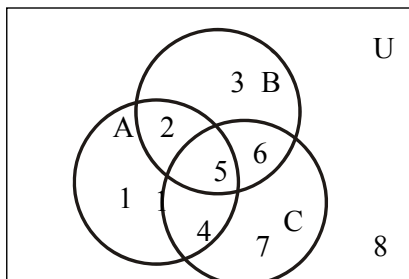

$$(1) \quad (A \cap B) \cap C^c$$

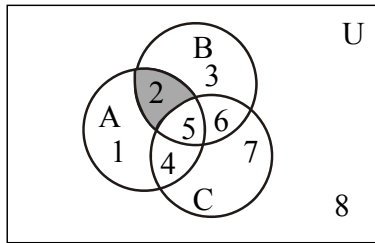

$(A \cap B) \cap C^c$ is shaded

(ii) $A^c \cup (B \cup C)$ is shaded.

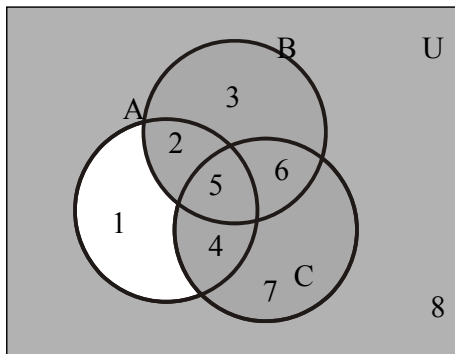

(iii) $(A - B) \cap C$

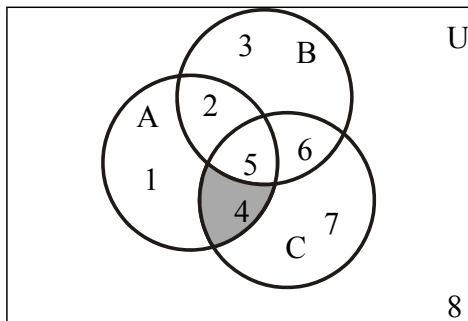

$(A - B) \cap C$ is shaded

(iii) $(A \cap B^c) \cup C^c$ is shaded.

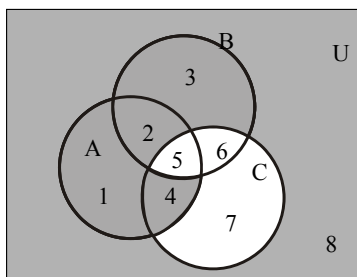

PROVING SET IDENTITIES BY VENN DIAGRAMS:

Prove the following using Venn Diagrams:

- (i) $A - (A - B) = A \cap B$
 (ii) $(A \cap B)^c = A^c \cup B^c$
 (iii) $A - B = A \cap B^c$

SOLUTION (i)

$$A - (A - B) = A \cap B$$

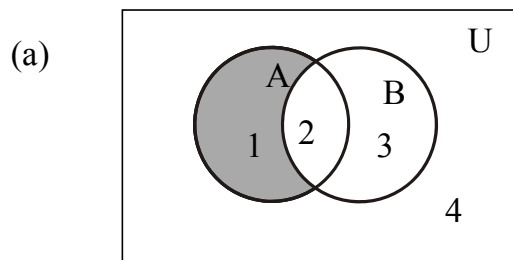

$$\begin{aligned} A &= \{ 1, 2 \} \\ B &= \{ 2, 3 \} \\ A - B &= \{ 1 \} \end{aligned}$$

$A - B$ is shaded

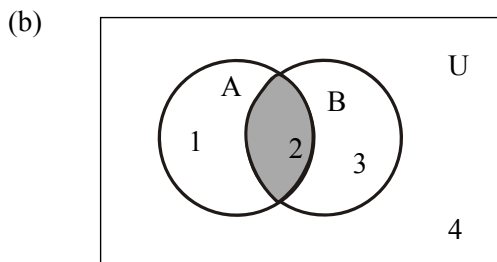

$$\begin{aligned} A &= \{ 1, 2 \} \\ A - B &= \{ 1 \} \\ A - (A - B) &= \{ 2 \} \end{aligned}$$

$A - (A - B)$ is shaded

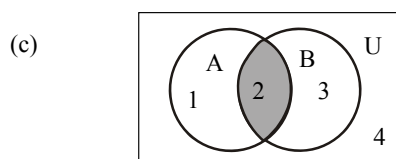

$A \cap B$ is shaded

$$\begin{aligned} A &= \{ 1, 2 \} \\ B &= \{ 2, 3 \} \\ A \cap B &= \{ 2 \} \end{aligned}$$

RESULT: $A - (A - B) = A \cap B$

SOLUTION (ii)

$$(A \cap B)^c = A^c \cup B^c$$

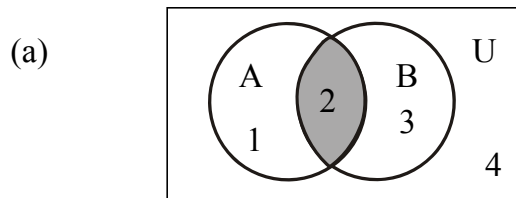

$$A \cap B$$

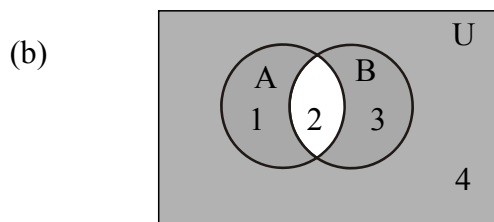

$$(A \cap B)^c$$

(c)

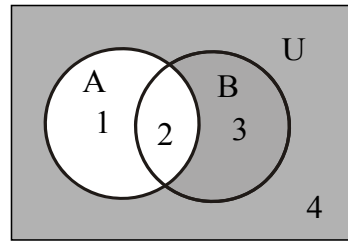
 A^c is shaded.

(d)

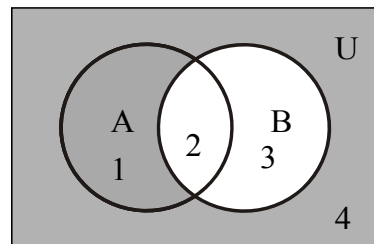
 B^c is shaded.

(e)

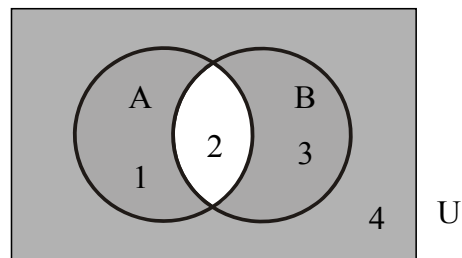
 $A^c \cup B^c$ is shaded.

Now diagrams (b) and (e) are same hence

$$\mathbf{RESULT:} \quad (A \cap B)^c = A^c \cup B^c$$

SOLUTION (iii)

$$\mathbf{A - B = A \cap B^c}$$

(a)

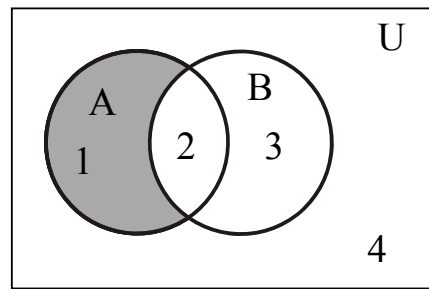
 $A - B$ is shaded.

(b)

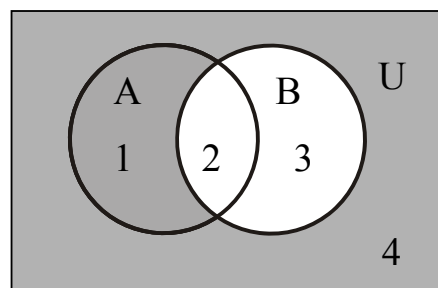
 B^c is shaded.

(c)

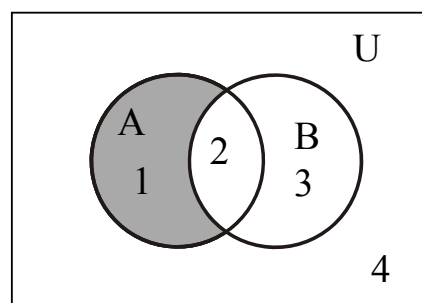
 $A \cap B^c$ is shaded

From diagrams (a) and (b) we can say

RESULT: $A - B = A \cap B^c$ **PROVING SET IDENTITIES BY MEMBERSHIP TABLE:**

Prove the following using Membership Table:

- (i) $A - (A - B) = A \cap B$
- (ii) $(A \cap B)^c = A^c \cup B^c$
- (iii) $A - B = A \cap B^c$

SOLUTION (i)

$$\mathbf{A - (A - B) = A \cap B}$$

A	B	A-B	A-(A-B)	A∩B
1	1	0	1	1
1	0	1	0	0
0	1	0	0	0
0	0	0	0	0

Since the last two columns of the above table are same hence the corresponding set expressions are same. That is

$$\mathbf{A - (A - B) = A \cap B}$$

SOLUTION (ii)

$$\mathbf{(A \cap B)^c = A^c \cup B^c}$$

A	B	A∩B	(A∩B) ^c	A ^c	B ^c	A ^c ∪ B ^c
1	1	1	0	0	0	0
1	0	0	1	0	1	1
0	1	0	1	1	0	1
0	0	0	1	1	1	1

Since the fourth and last columns of the above table are same hence the corresponding set expressions are same. That is

$$\mathbf{(A \cap B)^c = A^c \cup B^c}$$

SOLUTION (iii)

A	B	A - B	B ^c	A ∩ B ^c
1	1	0	0	0
1	0	1	1	1
0	1	0	0	0
0	0	0	1	0

Lecture No.9 Set identities

SET IDENTITIES:

Let A, B, C be subsets of a universal set U.

1. Idempotent Laws
 - a. $A \cup A = A$ b. $A \cap A = A$
2. Commutative Laws
 - a. $A \cup B = B \cup A$ b. $A \cap B = B \cap A$
3. Associative Laws
 - a. $A \cup (B \cap C) = (A \cup B) \cap C$
 - b. $A \cap (B \cup C) = (A \cap B) \cup C$
4. Distributive Laws
 - a. $A \cup (B \cap C) = (A \cup B) \cap (A \cup C)$
 - b. $A \cap (B \cup C) = (A \cap B) \cup (A \cap C)$
5. Identity Laws
 - a. $A \cup \emptyset = A$ b. $A \cap \emptyset = \emptyset$
 - c. $A \cup U = U$ d. $A \cap U = A$
6. Complement Laws
 - a. $A \cup A^c = U$ b. $A \cap A^c = \emptyset$
 - c. $U^c = \emptyset$ d. $\emptyset^c = U$
8. Double Complement Law

$$(A^c)^c = A$$
9. DeMorgan's Laws
 - a. $(A \cup B)^c = A^c \cap B^c$ b. $(A \cap B)^c = A^c \cup B^c$
10. Alternative Representation for Set Difference

$$A - B = A \cap B^c$$
11. Subset Laws
 - a. $A \cup B \subseteq C$ iff $A \subseteq C$ and $B \subseteq C$
 - b. $C \subseteq A \cap B$ iff $C \subseteq A$ and $C \subseteq B$
12. Absorption Laws
 - a. $A \cup (A \cap B) = A$ b. $A \cap (A \cup B) = A$

EXERCISE:

1. $A \subseteq A \cup B$
2. $A - B \subseteq A$
3. If $A \subseteq B$ and $B \subseteq C$ then $A \subseteq C$
4. $A \subseteq B$ if, and only if, $B^c \subseteq A^c$

1. Prove that $A \subseteq A \cup B$

SOLUTION

Here in order to prove the identity you should remember the definition of Subset of a set. We will take the arbitrary element of a set then show that, that element is the member of the other then the first set is the subset of the other. So

Let x be an arbitrary element of A, that is $x \in A$.

$$\Rightarrow x \in A \text{ or } x \in B$$

$\Rightarrow x \in A \cup B$
 But x is an arbitrary element of A .
 $\therefore A \subseteq A \cup B$ (proved)

1. Prove that $A - B \subseteq A$

SOLUTION

Let $x \in A - B$
 $\Rightarrow x \in A$ and $x \notin B$ (by definition of $A - B$)
 $\Rightarrow x \in A$ (in particular)
 But x is an arbitrary element of $A - B$
 $\therefore A - B \subseteq A$ (proved)

1. Prove that if $A \subseteq B$ and $B \subseteq C$, then $A \subseteq C$

SOLUTION

Suppose that $A \subseteq B$ and $B \subseteq C$
 Consider $x \in A$
 $\Rightarrow x \in B$ (as $A \subseteq B$)
 $\Rightarrow x \in C$ (as $B \subseteq C$)
 But x is an arbitrary element of A
 $\therefore A \subseteq C$ (proved)

1. Prove that $A \subseteq B$ iff $B^c \subseteq A^c$

SOLUTION:

Suppose $A \subseteq B$ {To prove $B^c \subseteq A^c$ }
 Let $x \in B^c$
 $\Rightarrow x \notin B$ (by definition of B^c)
 $\Rightarrow x \notin A$
 $\Rightarrow x \in A^c$ (by definition of A^c)

Now we know that implication and its contrapositivity are logically equivalent and the contrapositive statement of "if $x \in A$ then $x \in B$ " is: "if $x \notin B$ then $x \notin A$ " which is the definition of the $A \subseteq B$. Thus if we show for any two sets A and B , if $x \notin B$ then $x \notin A$ it means that

$A \subseteq B$. Hence
 But x is an arbitrary element of B^c
 $\therefore B^c \subseteq A^c$

Conversely,

Suppose $B^c \subseteq A^c$ {To prove $A \subseteq B$ }
 Let $x \in A$
 $\Rightarrow x \notin A^c$ (by definition of A^c)
 $\Rightarrow x \notin B^c$ ($\because B^c \subseteq A^c$)
 $\Rightarrow x \in B$ (by definition of B^c)
 But x is an arbitrary element of A .
 $\therefore A \subseteq B$ (proved)

EXERCISE:

Let A and B be subsets of a universal set U .
 Prove that $A - B = A \cap B^c$.

SOLUTIONLet $x \in A - B$

$$\Rightarrow x \in A \text{ and } x \notin B \quad (\text{definition of set difference})$$

$$\Rightarrow x \in A \text{ and } x \in B^c \quad (\text{definition of complement})$$

$$\Rightarrow x \in A \cap B^c \quad (\text{definition of intersection})$$

But x is an arbitrary element of $A - B$ so we can write

$$\therefore A - B \subseteq A \cap B^c \dots\dots\dots(1)$$

Conversely,let $y \in A \cap B^c$

$$\Rightarrow y \in A \text{ and } y \in B^c \quad (\text{definition of intersection})$$

$$\Rightarrow y \in A \text{ and } y \notin B \quad (\text{definition of complement})$$

$$\Rightarrow y \in A - B \quad (\text{definition of set difference})$$

But y is an arbitrary element of $A \cap B^c$

$$\therefore A \cap B^c \subseteq A - B \dots\dots\dots(2)$$

From (1) and (2) it follows that

$$A - B = A \cap B^c \quad (\text{as required})$$

EXERCISE:Prove the DeMorgan's Law: $(A \cup B)^c = A^c \cap B^c$ **PROOF**Let $x \in (A \cup B)^c$

$$\Rightarrow x \notin A \cup B \quad (\text{definition of complement})$$

$$x \notin A \text{ and } x \notin B \quad (\text{DeMorgan's Law of Logic})$$

$$\Rightarrow x \in A^c \text{ and } x \in B^c \quad (\text{definition of complement})$$

$$\Rightarrow x \in A^c \cap B^c \quad (\text{definition of intersection})$$

But x is an **arbitrary** element of $(A \cup B)^c$ so we have proved that

$$\therefore (A \cup B)^c \subseteq A^c \cap B^c \dots\dots\dots(1)$$

Conversely

let $y \in A^c \cap B^c$

$$\Rightarrow y \in A^c \text{ and } y \in B^c \quad (\text{definition of intersection})$$

$$\Rightarrow y \notin A \text{ and } y \notin B \quad (\text{definition of complement})$$

$$\Rightarrow y \notin A \cup B \quad (\text{DeMorgan's Law of Logic})$$

$$\Rightarrow y \in (A \cup B)^c \quad (\text{definition of complement})$$

But y is an arbitrary element of $A^c \cap B^c$

$$\therefore A^c \cap B^c \subseteq (A \cup B)^c \dots\dots\dots(2)$$

From (1) and (2) we have

$$(A \cup B)^c = A^c \cap B^c$$

Which is the Demorgan's Law.

EXERCISE:Prove the associative law: $A \cap (B \cap C) = (A \cap B) \cap C$ **PROOF:**Consider $x \in A \cap (B \cap C)$

$$\Rightarrow x \in A \text{ and } x \in B \cap C \quad (\text{definition of intersection})$$

$$\Rightarrow x \in A \text{ and } x \in B \text{ and } x \in C \quad (\text{definition of intersection})$$

$$\Rightarrow x \in A \cap B \text{ and } x \in C \quad (\text{definition of intersection})$$

$$\Rightarrow x \in (A \cap B) \cap C \quad (\text{definition of intersection})$$

But x is an arbitrary element of $A \cap (B \cap C)$

$$\therefore A \cap (B \cap C) \subseteq (A \cap B) \cap C \dots\dots(1)$$

Conversely

let $y \in (A \cap B) \cap C$

$$\Rightarrow y \in A \cap B \text{ and } y \in C \quad (\text{definition of intersection})$$

$$\Rightarrow y \in A \text{ and } y \in B \text{ and } y \in C \quad (\text{definition of intersection})$$

$$\Rightarrow y \in A \text{ and } y \in B \cap C \quad (\text{definition of intersection})$$

$$\Rightarrow y \in A \cap (B \cap C) \quad (\text{definition of intersection})$$

But y is an arbitrary element of $(A \cap B) \cap C$

$$\therefore (A \cap B) \cap C \subseteq A \cap (B \cap C) \dots\dots\dots(2)$$

From (1) & (2), we conclude that

$$A \cap (B \cap C) = (A \cap B) \cap C \quad (\text{proved})$$

EXERCISE:

Prove the distributive law: $A \cup (B \cap C) = (A \cup B) \cap (A \cup C)$

PROOF:

Let $x \in A \cup (B \cap C)$

$$\Rightarrow x \in A \text{ or } x \in B \cap C \quad (\text{definition of union})$$

Now since we have $x \in A$ or $x \in B \cap C$ it means that either x is in A or in $A \cap B$ it is in the $A \cup (B \cap C)$ so in order to show that

$A \cup (B \cap C)$ is the subset of $(A \cup B) \cap (A \cup C)$ we will consider both the cases when x is in A or x is in $B \cap C$ hence we will consider the two cases.

CASE I:

(when $x \in A$)

$$\Rightarrow x \in A \cup B \text{ and } x \in A \cup C \quad (\text{definition of union})$$

Hence,

$$x \in (A \cup B) \cap (A \cup C) \quad (\text{definition of intersection})$$

CASE II:

(when $x \in B \cap C$)

We have $x \in B$ and $x \in C$ (definition of intersection)

Now $x \in B \Rightarrow x \in A \cup B$ (definition of union)

and $x \in C \Rightarrow x \in A \cup C$ (definition of union)

Thus $x \in A \cup B$ and $x \in A \cup C$

$$\Rightarrow x \in (A \cup B) \cap (A \cup C)$$

In both of the cases $x \in (A \cup B) \cap (A \cup C)$

Accordingly,

$$A \cup (B \cap C) \subseteq (A \cup B) \cap (A \cup C) \dots\dots\dots(1)$$

Conversely,

Suppose $x \in (A \cup B) \cap (A \cup C)$

$$\Rightarrow x \in (A \cup B) \text{ and } x \in (A \cup C) \quad (\text{definition of intersection})$$

Consider the two cases $x \in A$ and $x \notin A$

CASE I: (when $x \in A$)

We have $x \in A \cup (B \cap C)$ (definition of union)

CASE II: (when $x \notin A$)

Since $x \in A \cup B$ and $x \notin A$, therefore $x \in B$

Also, since $x \in A \cup C$ and $x \notin A$, therefore $x \in C$. Thus $x \in B$ and $x \in C$
That is, $x \in B \cap C$

$$\Rightarrow x \in A \cup (B \cap C) \quad (\text{definition of union})$$

Hence in both cases

$$x \in A \cup (B \cap C)$$

$$\therefore (A \cup B) \cap C \subseteq A \cup (B \cap C) \dots \dots (2)$$

By (1) and (2), it follows that

$$A \cup (B \cap C) = (A \cup B) \cap (A \cup C) \quad (\text{proved})$$

EXERCISE:

For any sets A and B if $A \subseteq B$ then

$$(a) A \cap B = A \quad (b) A \cup B = B$$

SOLUTION:

$$(a) \text{ Let } x \in A \cap B$$

$$\Rightarrow x \in A \text{ and } x \in B$$

$$\Rightarrow x \in A \quad (\text{in particular})$$

$$\text{Hence } A \cap B \subseteq A \dots \dots (1)$$

Conversely,

$$\text{let } x \in A.$$

$$\text{Then } x \in B \quad (\text{since } A \subseteq B)$$

$$\text{Now } x \in A \text{ and } x \in B, \text{ therefore } x \in A \cap B$$

$$\text{Hence, } A \subseteq A \cap B \dots \dots (2)$$

From (1) and (2) it follows that

$$A = A \cap B \quad (\text{proved})$$

(b) Prove that $A \cup B = B$ when $A \subseteq B$

SOLUTION:

Suppose that $A \subseteq B$. Consider $x \in A \cup B$.

CASE I (when $x \in A$)

$$\text{Since } A \subseteq B, x \in A \Rightarrow x \in B$$

CASE II (when $x \notin A$)

$$\text{Since } x \in A \cup B, \text{ we have } x \in B$$

Thus $x \in B$ in both the cases, and we have

$$A \cup B \subseteq B \dots \dots (1)$$

Conversely

$$\text{let } x \in B. \text{ Then clearly, } x \in A \cup B$$

$$\text{Hence } B \subseteq A \cup B \dots \dots (2)$$

Combining (1) and (2), we deduce that

$$A \cup B = B \quad (\text{proved})$$

USING SET IDENTITIES:

For all subsets A and B of a universal set U, prove that

$$(A - B) \cup (A \cap B) = A$$

PROOF:

$$\text{LHS} = (A - B) \cup (A \cap B)$$

$$= (A \cap B^c) \cup (A \cap B) \quad (\text{Alternative representation for set difference})$$

$$\begin{aligned}
 &= A \cap (B^c \cup B) && \text{Distributive Law} \\
 &= A \cap U && \text{Complement Law} \\
 &= A && \text{Identity Law} \\
 &= \text{RHS} && \text{(proved)}
 \end{aligned}$$

The result can also be seen by Venn diagram.

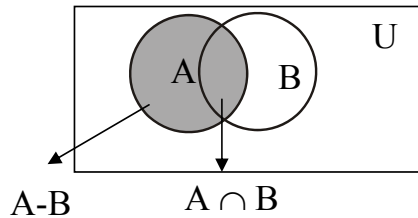

EXERCISE:

For any two sets A and B prove that $A - (A - B) = A \cap B$

SOLUTION

$$\begin{aligned}
 \text{LHS} &= A - (A - B) \\
 &= A - (A \cap B^c) && \text{Alternative representation for set difference} \\
 &= A \cap (A \cap B^c)^c && \text{Alternative representation for set difference} \\
 &= A \cap (A^c \cup (B^c)^c) && \text{DeMorgan's Law} \\
 &= A \cap (A^c \cup B) && \text{Double Complement Law} \\
 &= (A \cap A^c) \cup (A \cap B) && \text{Distributive Law} \\
 &= \emptyset \cup (A \cap B) && \text{Complement Law} \\
 &= A \cap B && \text{Identity Law} \\
 &= \text{RHS} && \text{(proved)}
 \end{aligned}$$

EXERCISE:

For all set A, B, and C prove that $(A - B) - C = (A - C) - B$

SOLUTION

$$\begin{aligned}
 \text{LHS} &= (A - B) - C \\
 &= (A \cap B^c) - C && \text{Alternative representation of set difference} \\
 &= (A \cap B^c) \cap C^c && \text{Alternative representation of set difference} \\
 &= A \cap (B^c \cap C^c) && \text{Associative Law} \\
 &= A \cap (C^c \cap B^c) && \text{Commutative Law} \\
 &= (A \cap C^c) \cap B^c && \text{Associative Law} \\
 &= (A - C) \cap B^c && \text{Alternative representation of set difference} \\
 &= (A - C) - B && \text{Alternative representation of set difference} \\
 &= \text{RHS} && \text{(proved)}
 \end{aligned}$$

EXERCISE:

Simplify $(B^c \cup (B^c - A))^c$

SOLUTION

$$\begin{aligned}
 (B^c \cup (B^c - A))^c &= (B^c \cup (B^c \cap A^c))^c \\
 &\text{Alternative representation for set difference} \\
 &= (B^c)^c \cap (B^c \cap A^c)^c && \text{DeMorgan's Law} \\
 &= B \cap ((B^c)^c \cup (A^c)^c) && \text{DeMorgan's Law} \\
 &= B \cap (B \cup A) && \text{Double Complement Law}
 \end{aligned}$$

$$= B$$

Absorption Law

is the simplified form of the given expression.

PROVING SET IDENTITIES BY MEMBERSHIP TABLE:

Prove the following using Membership Table:

- (i) $A - (A - B) = A \cap B$
 (ii) $(A \cap B)^c = A^c \cup B^c$
 (iii) $A - B = A \cap B^c$
 $A - (A - B) = A \cap B$

A	B	A-B	A-(A-B)	A∩B
1	1	0	1	1
1	0	1	0	0
0	1	0	0	0
0	0	0	0	0

$$(A \cap B)^c = A^c \cup B^c$$

A	B	A ∩ B	(A ∩ B) ^c	A ^c	B ^c	A ^c ∪ B ^c
1	1	1	0	0	0	0
1	0	0	1	0	1	1
0	1	0	1	1	0	1
0	0	0	1	1	1	1

SOLUTION (iii):

A	B	A - B	B ^c	A ∩ B ^c
1	1	0	0	0
1	0	1	1	1
0	1	0	0	0
0	0	0	1	0

Lecture No.10 Applications of Venn diagram

Exercise:

A number of computer users are surveyed to find out if they have a printer, modem or scanner. Draw separate Venn diagrams and shade the areas, which represent the following configurations.

- (i) modem and printer but no scanner
- (ii) scanner but no printer and no modem
- (iii) scanner or printer but no modem.
- (iv) no modem and no printer.

SOLUTION

Let

P represent the set of computer users having printer.

M represent the set of computer users having modem.

S represent the set of computer users having scanner.

SOLUTION (i)

Modem and printer but no Scanner is shaded.

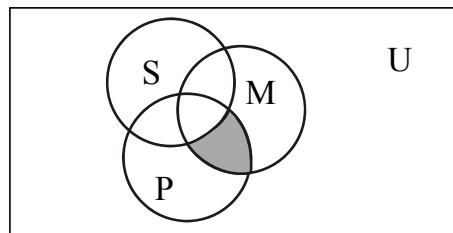

SOLUTION (ii)

Scanner but no printer and no modem is shaded.

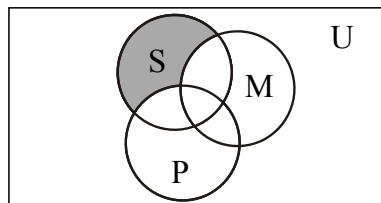

SOLUTION (iii)

scanner or printer but no modem is shaded.

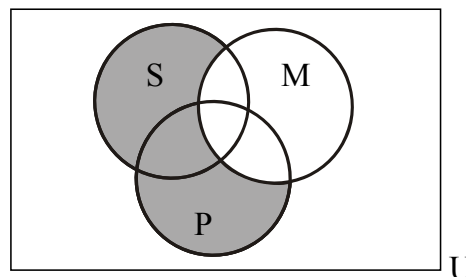

SOLUTION (iv)

no modem and no printer is shaded.

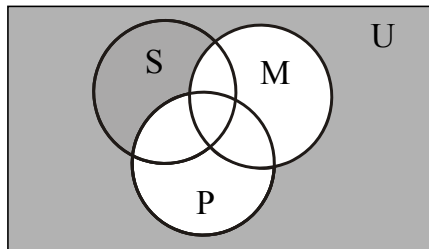
**EXERCISE:**

Of **21 typists** in an office, **5** use all **manual typewriters (M)**, **electronic typewriters (E)** and **word processors (W)**; **9** use **E** and **W**; **7** use **M** and **W**; **6** use **M** and **E**; but **no one** uses **M** only.

- (i) Represent this information in a Venn Diagram.
- (ii) If the same number of typists use electronic as use word processors, then
 1. (a) How many use word processors only,
 2. (b) How many use electronic typewriters?

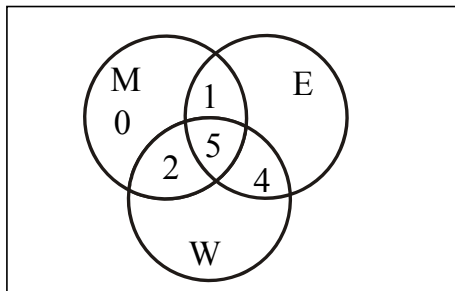
SOLUTION (i)**SOLUTION (ii-a)**

Let the number of typists using electronic typewriters (E) only be x , and the number of typists using word processors (W) only be y .

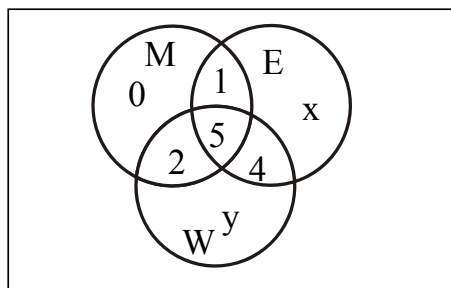

Total number of typists using E = Total Number of typists using W

$$1 + 5 + 4 + x = 2 + 5 + 4 + y$$

or, $x - y = 1$ (1)
 Also, total number of typists = 21
 $\Rightarrow 0 + x + y + 1 + 2 + 4 + 5 = 21$
 or, $x + y = 9$ (2)
 Solving (1) & (2), we get
 $x = 5, y = 4$
 \therefore Number of typists using word processor only is $y = 4$

(ii)-(b) How many typists use electronic typewriters?

SOLUTION:

Typists using electronic typewriters = No. of elements in E
 $= 1 + 5 + 4 + x$
 $= 1 + 5 + 4 + 5$
 $= 15$

EXERCISE

In a school, 100 students have access to three software packages, A, B and C
 28 did not use any software
 8 used only packages A
 26 used only packages B
 7 used only packages C
 10 used all three packages
 13 used both A and B

- (i) Draw a Venn diagram with all sets enumerated as far as possible. Label the two subsets which cannot be enumerated as x and y, in any order.
- (ii) If twice as many students used package B as package A, write down a pair of simultaneous equations in x and y.
- (iii) Solve these equations to find x and y.
- (iv) How many students used package C?

SOLUTION(i)

Venn Diagram with all sets enumerated.

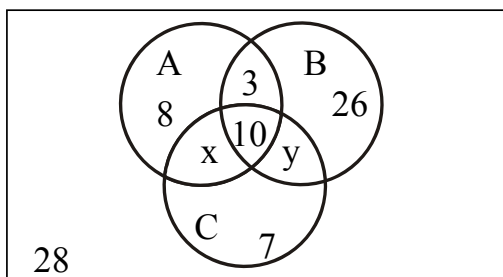

(ii) If twice as many students used package B as package A, write down a pair of simultaneous equations in x and y.

SOLUTION:

We are given

students using package B = 2 (# students using package A)

Now the number of students which used package B and A are clear from the diagrams given below. So we have the following equation

$$\begin{aligned} \Rightarrow 3 + 10 + 26 + y &= 2(8 + 3 + 10 + x) \\ \Rightarrow 39 + y &= 42 + 2x \\ \text{or } y &= 2x + 3 \dots\dots\dots(1) \end{aligned}$$

Also, total number of students = 100.

$$\begin{aligned} \text{Hence, } 8 + 3 + 26 + 10 + 7 + 28 + x + y &= 100 \\ \text{or } 82 + x + y &= 100 \end{aligned}$$

$$\text{or } x + y = 18 \dots\dots\dots(2)$$

(iii) Solving simultaneous equations for x and y.

SOLUTION:

$$\begin{aligned} y &= 2x + 3 \dots\dots\dots(1) \\ x + y &= 18 \dots\dots\dots(2) \end{aligned}$$

Using (1) in (2), we get,

$$\begin{aligned} x + (2x + 3) &= 18 \\ \text{or } 3x + 3 &= 18 \\ \text{or } 3x &= 15 \\ \Rightarrow x &= 5 \end{aligned}$$

Consequently $y = 13$

How many students used package C?

SOLUTION:

$$\begin{aligned} \text{No. of students using package C} &= x + y + 10 + 7 \\ &= 5 + 13 + 10 + 7 \\ &= 35 \end{aligned}$$

EXAMPLE:

Use diagrams to show the validity of the following argument:

All human beings are mortal

Zeus is not mortal

\therefore Zeus is not a human being

SOLUTION:

The premise "All human beings are mortal" is pictured by placing a disk labeled "human beings" inside a disk labeled "mortals". We place the disk of human beings inside the disk of mortals because there are things which are mortal but not human beings so the set of human beings is subset of set of mortals.

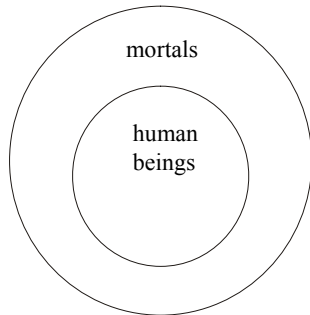

The second premise “Zeus is not mortal” could be pictured by placing a dot labeled “Zeus” outside the disk labeled “mortals”

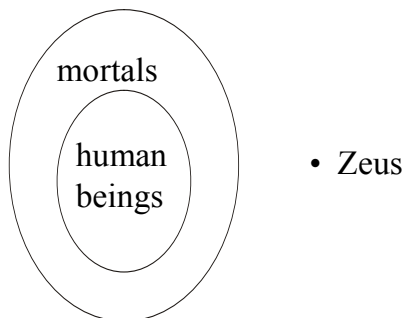

Argument is valid.

EXAMPLE:

Use a diagram to show the invalidity of the following argument:

All human beings are mortal.

Farhan is mortal

∴ Farhan is a human being

SOLUTION:

The first premise “All human beings are mortal” is pictured as:

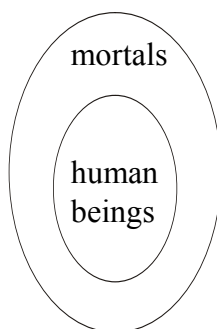

The second premise “Farhan is mortal” is represented by a dot labeled “Farhan” inside the mortal disk in either of the following two ways:

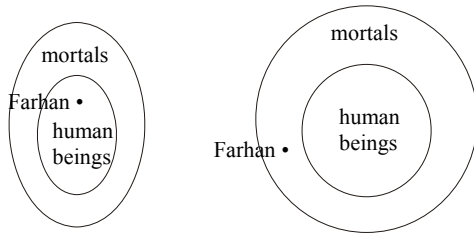

argument is invalid.

EXAMPLE

Use diagrams to test the following argument for validity:

No polynomial functions have horizontal asymptotes.

This function has a horizontal asymptote.

\therefore This function is not polynomial.

SOLUTION

The premise “No polynomial functions have horizontal asymptotes” can be represented diagrammatically by two **disjoint** disks labeled “polynomial functions” and “functions with horizontal tangents.”

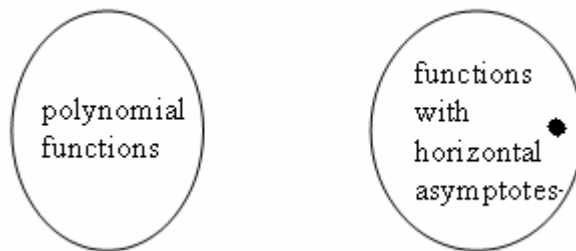

The argument is valid.

EXERCISE:

Use a diagram to show that the following argument can have true premises and a false conclusion.

All dogs are carnivorous.

Jack is not a dog.

\therefore Jack is not carnivorous

SOLUTION:

The premise “All dogs are carnivorous” is pictured by placing a disk labeled “dogs” inside a disk labeled “carnivorous”. \therefore

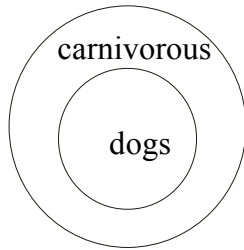

The second premise “Jack is not a dog” could be represented by placing a dot outside the disk labeled “dogs” but inside the disk labeled “carnivorous” to make the conclusion “Jack is not carnivorous” false.

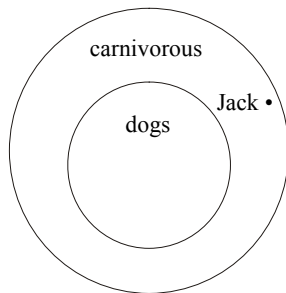

EXERCISE:

Indicate by drawing diagrams, whether the argument is valid or invalid.

No college cafeteria food is good.

No good food is wasted.

∴ No college cafeteria food is wasted.

SOLUTION

The premise “No college food is good” could be represented by two disjoint disks shown below.

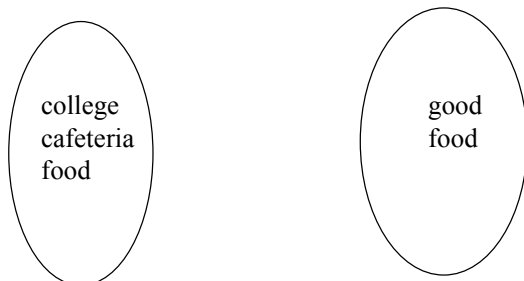

The next premise “No good food is wasted” introduces another disk labeled “wasted food” that does not overlap the disk labeled “good food”, but may intersect with the disk labeled “college cafeteria food.”

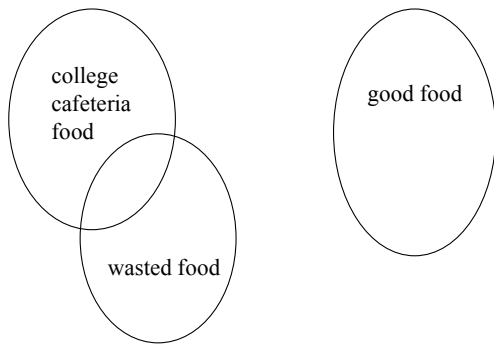

Argument is **invalid**

PARTITION OF A SET

A set may be divided up into its disjoint subsets. Such division is called a partition.

More precisely,

A partition of a set A is a collection of non- empty subsets $\{A_1, A_2, \dots, A_n\}$ of A , such that

1. $A = A_1 \cup A_2 \cup \dots \cup A_n$
2. A_1, A_2, \dots, A_n are mutually disjoint (or pair wise disjoint),
i.e., $\forall i, j = 1, 2, \dots, n \ A_i \cap A_j = \emptyset$ whenever $i \neq j$

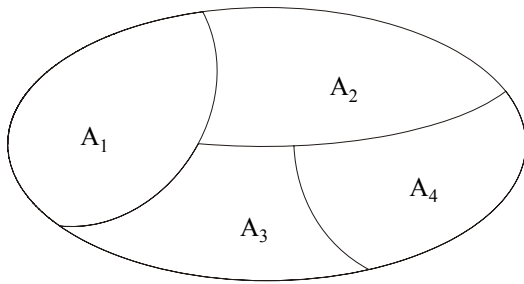

A partition of a set

POWER SET:

The power set of a set A is the set of all subsets of A , denoted $P(A)$.

EXAMPLE:

Let $A = \{1, 2\}$, then
 $P(A) = \{\emptyset, \{1\}, \{2\}, \{1, 2\}\}$

REMARK:

If A has n elements then $P(A)$ has 2^n elements.

EXERCISE

- a. Find $P(\emptyset)$ b. Find $P(P(\emptyset))$ c. Find $P(P(P(\emptyset)))$

SOLUTION:

a. Since \emptyset contains no element, therefore $P(\emptyset)$ will contain $2^0 = 1$ element.
 $P(\emptyset) = \{\emptyset\}$

- a. Since $P(\emptyset)$ contains one element, namely \emptyset , therefore $P(P(\emptyset))$ will contain $2^1 = 2$ elements

$$P(P(\emptyset)) = \{\emptyset, \{\emptyset\}\}$$

- a. Since $P(P(\emptyset))$ contains two elements, namely \emptyset and $\{\emptyset\}$, so $P(P(P(\emptyset)))$ will contain $2^2 = 4$ elements.

$$P(P(P(\emptyset))) = \{\emptyset, \{\emptyset\}, \{\{\emptyset\}\}, \{\emptyset, \{\emptyset\}\}\}$$

Lecture No.11 Relations

ORDERED PAIR:

An ordered pair (a, b) consists of two elements “a” and “b” in which “a” is the first element and “b” is the second element.

The ordered pairs (a, b) and (c, d) are equal if, and only if, $a = c$ and $b = d$.

Note that (a, b) and (b, a) are not equal unless $a = b$.

EXERCISE:

Find x and y given $(2x, x + y) = (6, 2)$

SOLUTION:

Two ordered pairs are equal if and only if the corresponding components are equal. Hence, we obtain the equations:

$$2x = 6 \dots\dots\dots(1)$$

and $x + y = 2 \dots\dots\dots(2)$

Solving equation (1) we get $x = 3$ and when substituted in (2) we get $y = -1$.

ORDERED n-TUPLE:

The ordered n -tuple, (a_1, a_2, \dots, a_n) consists of elements a_1, a_2, \dots, a_n together with the ordering: first a_1 , second a_2 , and so forth up to a_n . In particular, an ordered 2-tuple is called an ordered pair, and an ordered 3-tuple is called an ordered triple.

Two ordered n -tuples (a_1, a_2, \dots, a_n) and (b_1, b_2, \dots, b_n) are equal if and only if each corresponding pair of their elements is equal, i.e., $a_i = b_i$, for all $i = 1, 2, \dots, n$.

CARTESIAN PRODUCT OF TWO SETS:

Let A and B be sets. The Cartesian product of A and B , denoted $A \times B$ (read “A cross B”) is the set of all ordered pairs (a, b) , where a is in A and b is in B .

Symbolically:

$$A \times B = \{(a, b) \mid a \in A \text{ and } b \in B\}$$

NOTE

If set A has m elements and set B has n elements then $A \times B$ has $m \times n$ elements.

EXAMPLE:

Let $A = \{1, 2\}$, $B = \{a, b, c\}$ then

$$A \times B = \{(1, a), (1, b), (1, c), (2, a), (2, b), (2, c)\}$$

$$B \times A = \{(a, 1), (a, 2), (b, 1), (b, 2), (c, 1), (c, 2)\}$$

$$A \times A = \{(1, 1), (1, 2), (2, 1), (2, 2)\}$$

$$B \times B = \{(a, a), (a, b), (a, c), (b, a), (b, b), (b, c), (c, a), (c, b), (c, c)\}$$

REMARK:

1. $A \times B \neq B \times A$ for non-empty and unequal sets A and B .
2. $A \times \phi = \phi \times A = \phi$
3. $|A \times B| = |A| \times |B|$

CARTESIAN PRODUCT OF MORE THAN TWO SETS:

The Cartesian product of sets A_1, A_2, \dots, A_n , denoted $A_1 \times A_2 \times \dots \times A_n$, is the set of all ordered n -tuples (a_1, a_2, \dots, a_n) where $a_1 \in A_1, a_2 \in A_2, \dots, a_n \in A_n$.

Symbolically:

$$A_1 \times A_2 \times \dots \times A_n = \{(a_1, a_2, \dots, a_n) \mid a_i \in A_i, \text{ for } i=1, 2, \dots, n\}$$

BINARY RELATION:

Let A and B be sets. A (binary) relation R from A to B is a subset of $A \times B$.

When $(a, b) \in R$, we say a is related to b by R, written $a R b$.

Otherwise if $(a, b) \notin R$, we write $a \not R b$.

EXAMPLE:

$$\text{Let } A = \{1, 2\}, \quad B = \{1, 2, 3\}$$

$$\text{Then } A \times B = \{(1, 1), (1, 2), (1, 3), (2, 1), (2, 2), (2, 3)\}$$

Let

$$R_1 = \{(1, 1), (1, 3), (2, 2)\}$$

$$R_2 = \{(1, 2), (2, 1), (2, 2), (2, 3)\}$$

$$R_3 = \{(1, 1)\}$$

$$R_4 = A \times B$$

$$R_5 = \emptyset$$

All being subsets of $A \times B$ are relations from A to B.

DOMAIN OF A RELATION:

The domain of a relation R from A to B is the set of all first elements of the ordered pairs which belong to R denoted $\text{Dom}(R)$.

Symbolically:

$$\text{Dom}(R) = \{a \in A \mid (a, b) \in R\}$$

RANGE OF A RELATION:

The range of A relation R from A to B is the set of all second elements of the ordered pairs which belong to R denoted $\text{Ran}(R)$.

Symbolically:

$$\text{Ran}(R) = \{b \in B \mid (a, b) \in R\}$$

EXERCISE:

$$\text{Let } A = \{1, 2\}, \quad B = \{1, 2, 3\},$$

Define a binary relation R from A to B as follows:

$$R = \{(a, b) \in A \times B \mid a < b\}$$

Then

- Find the ordered pairs in R.
- Find the Domain and Range of R.
- Is $1R3$, $2R2$?

SOLUTION:

$$\text{Given } A = \{1, 2\}, \quad B = \{1, 2, 3\},$$

$$A \times B = \{(1, 1), (1, 2), (1, 3), (2, 1), (2, 2), (2, 3)\}$$

- $R = \{(a, b) \in A \times B \mid a < b\}$
 $R = \{(1, 2), (1, 3), (2, 3)\}$
- $\text{Dom}(R) = \{1, 2\}$ and $\text{Ran}(R) = \{2, 3\}$
 - Since $(1, 3) \in R$ so $1R3$
 But $(2, 2) \notin R$ so 2 is not related with 3.

EXAMPLE:

Let $A = \{\text{eggs, milk, corn}\}$ and $B = \{\text{cows, goats, hens}\}$
 Define a relation R from A to B by $(a, b) \in R$ iff a is produced by b .
 Then $R = \{(\text{eggs, hens}), (\text{milk, cows}), (\text{milk, goats})\}$
 Thus, with respect to this relation $\text{eggs } R \text{ hens}$, $\text{milk } R \text{ cows}$, etc.

EXERCISE :

Find all binary relations from $\{0,1\}$ to $\{1\}$

SOLUTION:

Let $A = \{0,1\}$ & $B = \{1\}$
 Then $A \times B = \{(0,1), (1,1)\}$
 All binary relations from A to B are in fact all subsets of $A \times B$, which are:

$$R_1 = \emptyset$$

$$R_2 = \{(0,1)\}$$

$$R_3 = \{(1,1)\}$$

$$R_4 = \{(0,1), (1,1)\} = A \times B$$

REMARK:

If $|A| = m$ and $|B| = n$

Then as we know that the number of elements in $A \times B$ are $m \times n$. Now as we know that the total number of and the total number of relations from A to B are $2^{m \times n}$.

RELATION ON A SET:

A relation on the set A is a relation from A to A .
 In other words, a relation on a set A is a subset of $A \times A$.

EXAMPLE: :

Let $A = \{1, 2, 3, 4\}$
 Define a relation R on A as
 $(a,b) \in R$ iff a divides b {symbolically written as $a | b$ }
 Then $R = \{(1,1), (1,2), (1,3), (1,4), (2,2), (2,4), (3,3), (4,4)\}$

REMARK:

For any set A

1. $A \times A$ is known as the universal relation.
2. \emptyset is known as the empty relation.

EXERCISE:

Define a binary relation E on the set of the integers Z , as follows:

for all $m, n \in Z$, $m E n \Leftrightarrow m - n$ is even.

- a. Is $0E0$? Is $5E2$? Is $(6,6) \in E$? Is $(-1,7) \in E$?
- b. Prove that for any even integer n , $nE0$.

SOLUTION

- $E = \{(m,n) \in Z \times Z \mid m - n \text{ is even}\}$
- a. (i) $(0,0) \in Z \times Z$ and $0-0 = 0$ is even
 Therefore $0E0$.

- (ii) $(5,2) \in Z \times Z$ but $5-2 = 3$ is not even
 so $5 \notin 2$
- (iii) $(6,6) \in E$ since $6-6 = 0$ is an even integer.
- (iv) $(-1,7) \in E$ since $(-1) - 7 = -8$ is an even integer.
- a. For any even integer, n , we have
 $n - 0 = n$, an even integer
 so $(n, 0) \in E$ or equivalently $n \in E 0$

COORDINATE DIAGRAM (GRAPH) OF A RELATION:

Let $A = \{1, 2, 3\}$ and $B = \{x, y\}$

Let R be a relation from A to B defined as

$$R = \{(1, y), (2, x), (2, y), (3, x)\}$$

The relation may be represented in a coordinate diagram as follows:

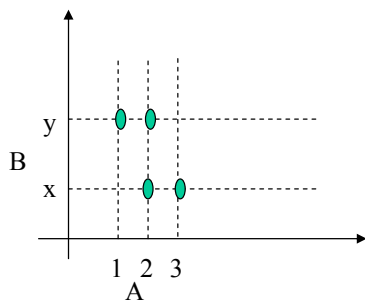

EXAMPLE:

Draw the graph of the binary relation C from R to R defined as follows:

$$\text{for all } (x, y) \in R \times R, (x, y) \in C \Leftrightarrow x^2 + y^2 = 1$$

SOLUTION

All ordered pairs (x, y) in relation C satisfies the equation $x^2 + y^2 = 1$, which when solved for y gives

Clearly y is real, whenever $-1 \leq x \leq 1$

Similarly x is real, whenever $-1 \leq y \leq 1$

Hence the graph is limited in the range $-1 \leq x \leq 1$ and $-1 \leq y \leq 1$

The graph of relation is

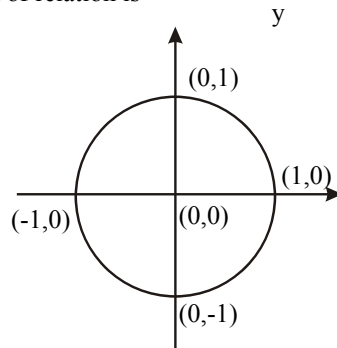

ARROW DIAGRAM OF A RELATION:

Let

$$A = \{1, 2, 3\}, B = \{x, y\}$$

$$\text{and } R = \{(1,y), (2,x), (2,y), (3,x)\}$$

be a relation from A to B.

The arrow diagram of R is:

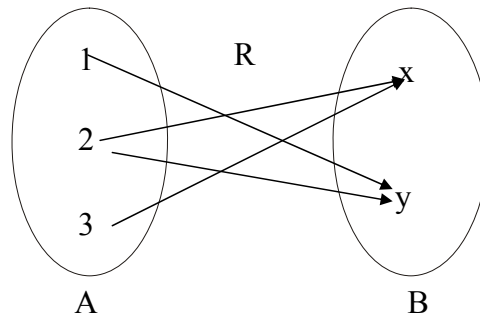
**DIRECTED GRAPH OF A RELATION:**

Let $A = \{0, 1, 2, 3\}$

$$\text{and } R = \{(0,0), (1,3), (2,1), (2,2), (3,0), (3,1)\}$$

be a binary relation on A.

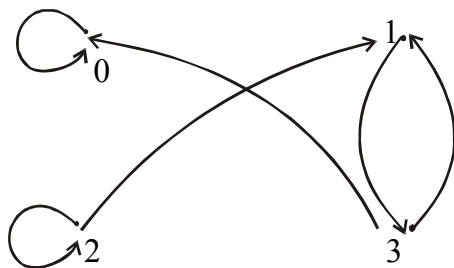
**DIRECTED GRAPH****MATRIX REPRESENTATION OF A RELATION**

Let $A = \{a_1, a_2, \dots, a_n\}$ and $B = \{b_1, b_2, \dots, b_m\}$. Let R be a relation from A to B. Define the $n \times m$ order matrix M by

$$m(i, j) = \begin{cases} 1 & \text{if } (a_i, b_j) \in R \\ 0 & \text{if } (a_i, b_j) \notin R \end{cases}$$

for $i=1, 2, \dots, n$ and $j=1, 2, \dots, m$

EXAMPLE:

Let $A = \{1, 2, 3\}$ and $B = \{x, y\}$

Let R be a relation from A to B defined as

$$R = \{(1,y), (2,x), (2,y), (3,x)\}$$

$$M = \begin{matrix} & \begin{matrix} x & y \end{matrix} \\ \begin{matrix} 1 \\ 2 \\ 3 \end{matrix} & \begin{bmatrix} 0 & 1 \\ 1 & 1 \\ 1 & 0 \end{bmatrix}_{3 \times 2} \end{matrix}$$

EXAMPLE:

For the relation matrix.

$$M = \begin{matrix} & \begin{matrix} 1 & 2 & 3 \end{matrix} \\ \begin{matrix} 1 \\ 2 \\ 3 \end{matrix} & \begin{bmatrix} 1 & 0 & 1 \\ 1 & 0 & 0 \\ 0 & 1 & 1 \end{bmatrix} \end{matrix}$$

1. List the set of ordered pairs represented by M .
2. Draw the directed graph of the relation.

SOLUTION:

The relation corresponding to the given Matrix is

$$\bullet R = \{(1,1), (1,3), (2,1), (3,1), (3,2), (3,3)\}$$

And its Directed graph is given below

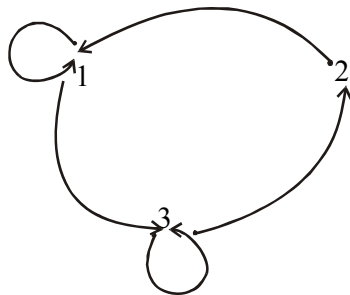
**EXERCISE:**

Let $A = \{2, 4\}$ and $B = \{6, 8, 10\}$ and define relations R and S from A to B as follows:

$$\text{for all } (x,y) \in A \times B, \quad x R y \Leftrightarrow x \mid y$$

$$\text{for all } (x,y) \in A \times B, \quad x S y \Leftrightarrow y - 4 = x$$

State explicitly which ordered pairs are in $A \times B$, R , S , $R \cup S$ and $R \cap S$.

SOLUTION

$$A \times B = \{(2,6), (2,8), (2,10), (4,6), (4,8), (4,10)\}$$

$$R = \{(2,6), (2,8), (2,10), (4,8)\}$$

$$S = \{(2,6), (4,8)\}$$

$$R \cup S = \{(2,6), (2,8), (2,10), (4,8)\} = R$$

$$R \cap S = \{(2,6), (4,8)\} = S$$

Lecture No.12 Types of relations

REFLEXIVE RELATION:

Let R be a relation on a set A . R is reflexive if, and only if, for all $a \in A$, $(a, a) \in R$. Or equivalently aRa .

That is, each element of A is related to itself.

REMARK

R is not reflexive iff there is an element “ a ” in A such that $(a, a) \notin R$. That is, some element “ a ” of A is not related to itself.

EXAMPLE:

Let $A = \{1, 2, 3, 4\}$ and define relations R_1, R_2, R_3, R_4 on

A as follows:

$$R_1 = \{(1, 1), (3, 3), (2, 2), (4, 4)\}$$

$$R_2 = \{(1, 1), (1, 4), (2, 2), (3, 3), (4, 3)\}$$

$$R_3 = \{(1, 1), (1, 2), (2, 1), (2, 2), (3, 3), (4, 4)\}$$

$$R_4 = \{(1, 3), (2, 2), (2, 4), (3, 1), (4, 4)\}$$

Then,

R_1 is reflexive, since $(a, a) \in R_1$ for all $a \in A$.

R_2 is not reflexive, because $(4, 4) \notin R_2$.

R_3 is reflexive, since $(a, a) \in R_3$ for all $a \in A$.

R_4 is not reflexive, because $(1, 1) \notin R_4, (3, 3) \notin R_4$

DIRECTED GRAPH OF A REFLEXIVE RELATION:

The directed graph of every reflexive relation includes an arrow from every point to the point itself (i.e., a loop).

EXAMPLE :

Let $A = \{1, 2, 3, 4\}$ and define relations $R_1, R_2, R_3,$ and

R_4 on A by

$$R_1 = \{(1, 1), (3, 3), (2, 2), (4, 4)\}$$

$$R_2 = \{(1, 1), (1, 4), (2, 2), (3, 3), (4, 3)\}$$

$$R_3 = \{(1, 1), (1, 2), (2, 1), (2, 2), (3, 3), (4, 4)\}$$

$$R_4 = \{(1, 3), (2, 2), (2, 4),$$

$(3, 1), (4, 4)\}$

Then their directed graphs are

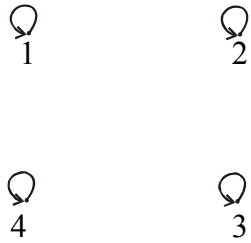

R_1 is reflexive because at every point of the set A we have a loop in the graph.

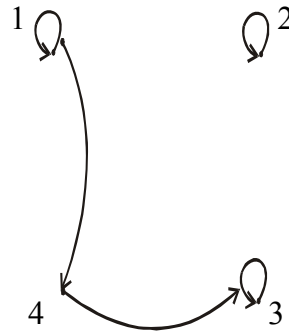

R_2 is not reflexive, as there is no loop at 4.

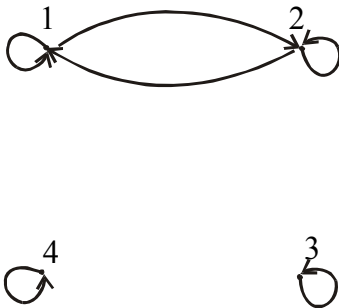

R_3 is reflexive

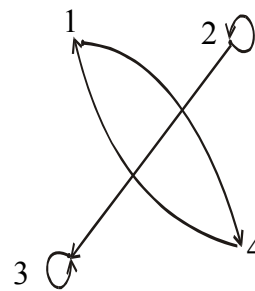

R_4 is not reflexive, as there are no loops at 1 and 3.

MATRIX REPRESENTATION OF A REFLEXIVE RELATION:

Let $A = \{a_1, a_2, \dots, a_n\}$. A Relation R on A is reflexive if and only if

$(a_i, a_i) \in R \forall i=1,2, \dots, n$.

Accordingly, R is **reflexive** if all the elements on the **main diagonal** of the matrix M representing R are equal to 1.

EXAMPLE:

The relation $R = \{(1,1), (1,3), (2,2), (3,2), (3,3)\}$ on $A = \{1,2,3\}$ represented by the following matrix M , is reflexive.

$$M = \begin{matrix} & \begin{matrix} 1 & 2 & 3 \end{matrix} \\ \begin{matrix} 1 \\ 2 \\ 3 \end{matrix} & \begin{bmatrix} 1 & 0 & 1 \\ 0 & 1 & 0 \\ 0 & 1 & 1 \end{bmatrix} \end{matrix}$$

SYMMETRIC RELATION

Let R be a relation on a set A . R is symmetric if, and only if, for all $a, b \in A$, if $(a, b) \in R$ then $(b, a) \in R$.

That is, if aRb then bRa .

REMARK

R is not symmetric iff there are elements a and b in A such that $(a, b) \in R$ but $(b, a) \notin R$.

EXAMPLE

Let $A = \{1, 2, 3, 4\}$ and define relations $R_1, R_2, R_3,$ and R_4 on A as follows.

$$R_1 = \{(1, 1), (1, 3), (2, 4), (3, 1), (4, 2)\}$$

$$R_2 = \{(1, 1), (2, 2), (3, 3), (4, 4)\}$$

$$R_3 = \{(2, 2), (2, 3), (3, 4)\}$$

$$R_4 = \{(1, 1), (2, 2), (3, 3), (4, 3), (4, 4)\}$$

Then R_1 is symmetric because for every ordered pair (a, b) in R_1 we have (b, a) in R_1 for example we have $(1, 3)$ in R_1 then we have $(3, 1)$ in R_1 similarly all other ordered pairs can be checked.

R_2 is also symmetric symmetric we say it is vacuously true.

R_3 is not symmetric, because $(2, 3) \in R_3$ but $(3, 2) \notin R_3$.

R_4 is not symmetric because $(4, 3) \in R_4$ but $(3, 4) \notin R_4$.

DIRECTED GRAPH OF A SYMMETRIC RELATION

For a symmetric directed graph whenever there is an arrow going from one point of the graph to a second, there is an arrow going from the second point back to the first.

EXAMPLE

Let $A = \{1, 2, 3, 4\}$ and define relations $R_1, R_2, R_3,$ and R_4 on A by the directed graphs:

$$R_1 = \{(1, 1), (1, 3), (2, 4), (3, 1), (4, 2)\}$$

$$R_2 = \{(1, 1), (2, 2), (3, 3), (4, 4)\}$$

$$R_3 = \{(2, 2), (2, 3), (3, 4)\}$$

$$R_4 = \{(1, 1), (2, 2), (3, 3), (4, 3), (4, 4)\}$$

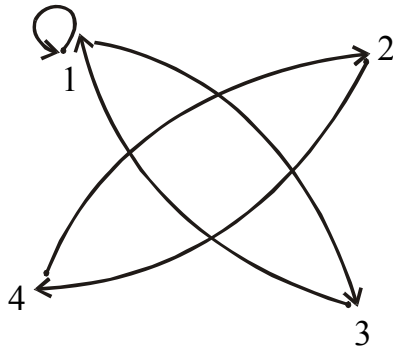

R_1 is symmetric

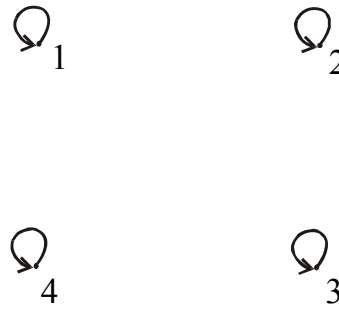

R_2 is symmetric

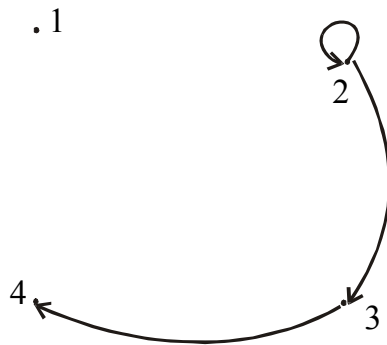

R_3 is not symmetric since there are arrows from 2 to 3 and from 3 to 4 but not conversely

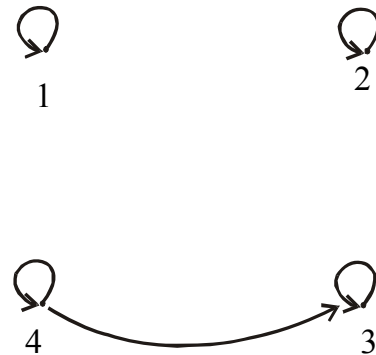

R_4 is not symmetric since there is an arrow from 4 to 3 but no arrow from 3 to 4

MATRIX REPRESENTATION OF A SYMMETRIC RELATION

Let

$$A = \{a_1, a_2, \dots, a_n\}.$$

A relation R on A is symmetric if and only if for all $a_i, a_j \in A$, if $(a_i, a_j) \in R$ then $(a_j, a_i) \in R$.

Accordingly, R is symmetric if the elements in the i th row are the same as the elements in the i th column of the matrix M representing R . More precisely, M is a symmetric matrix. i.e. $M = M^t$

EXAMPLE

The relation $R = \{(1,3), (2,2), (3,1), (3,3)\}$ on $A = \{1,2,3\}$ represented by the following matrix M is symmetric.

$$M = \begin{matrix} & \begin{matrix} 1 & 2 & 3 \end{matrix} \\ \begin{matrix} 1 \\ 2 \\ 3 \end{matrix} & \begin{bmatrix} 0 & 0 & 1 \\ 0 & 1 & 0 \\ 1 & 0 & 1 \end{bmatrix} \end{matrix}$$

TRANSITIVE RELATION

Let R be a relation on a set A . R is transitive if and only if for all $a, b, c \in A$, if $(a, b) \in R$ and $(b, c) \in R$ then $(a, c) \in R$. That is, if aRb and bRc then aRc .

In words, if any one element is related to a second and that second element is related to a third, then the first is related to the third. Note that the “first”, “second” and “third” elements need not to be distinct.

REMARK

R is not transitive iff there are elements a, b, c in A such that $(a,b) \in R$ and $(b,c) \in R$ but $(a,c) \notin R$.

EXAMPLE

Let $A = \{1, 2, 3, 4\}$ and define relations R_1 , R_2 and R_3 on A as follows:

$$R_1 = \{(1, 1), (1, 2), (1, 3), (2, 3)\}$$

$$R_2 = \{(1, 2), (1, 4), (2, 3), (3, 4)\}$$

$$R_3 = \{(2, 1), (2, 4), (2, 3), (3,4)\}$$

Then R_1 is transitive because $(1, 1), (1, 2)$ are in R then to be transitive relation $(1,2)$ must be there and it belongs to R . Similarly for other order pairs.

R_2 is not transitive since $(1,2)$ and $(2,3) \in R_2$ but $(1,3) \notin R_2$.

R_3 is transitive.

DIRECTED GRAPH OF A TRANSITIVE RELATION

For a transitive directed graph, whenever there is an arrow going from one point to the second, and from the second to the third, there is an arrow going directly from the first to the third.

EXAMPLE

Let $A = \{1, 2, 3, 4\}$ and define relations R_1 , R_2 and R_3 on A by the directed graphs:

$$R_1 = \{(1, 1), (1, 2), (1, 3), (2, 3)\}$$

$$R_2 = \{(1, 2), (1, 4), (2, 3), (3, 4)\}$$

$$R_3 = \{(2, 1), (2, 4), (2, 3), (3, 4)\}$$

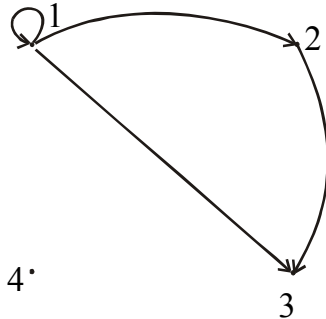

R_1 is transitive

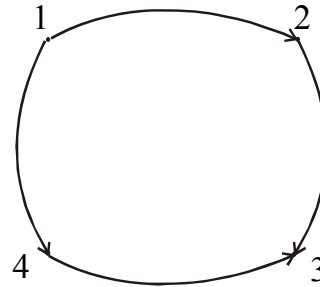

R_2 is not transitive since there is an arrow from 1 to 2 and from 2 to 3 but no arrow from 1 to 3 directly

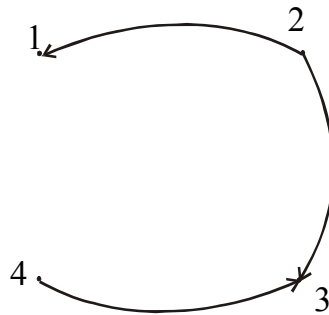

R_3 is transitive

EXERCISE:

Let $A = \{1, 2, 3, 4\}$ and define the null relation \emptyset and universal relation $A \times A$ on A . Test these relations for reflexive, symmetric and transitive properties.

SOLUTION:

Reflexive:

- (i) \emptyset is not reflexive since $(1,1), (2,2), (3,3), (4,4) \notin \emptyset$.
- (ii) $A \times A$ is reflexive since $(a,a) \in A \times A$ for all $a \in A$.

Symmetric

- (i) For the null relation \emptyset on A to be symmetric, it must satisfy the implication:

if $(a,b) \in \emptyset$ then $(a, b) \in \emptyset$.

Since $(a, b) \in \emptyset$ is never true, the implication is vacuously true or true by default. Hence \emptyset is symmetric.

(ii) The universal relation $A \times A$ is symmetric, for it contains all ordered pairs of elements of A . Thus,

if $(a, b) \in A \times A$ then $(b, a) \in A \times A$ for all a, b in A .

Transitive

(i) The null relation \emptyset on A is transitive, because the implication.

if $(a, b) \in \emptyset$ and $(b, c) \in \emptyset$ then $(a, c) \in \emptyset$ is true by default, since the condition $(a, b) \in \emptyset$ is always false.

(i) The universal relation $A \times A$ is transitive for it contains all ordered pairs of elements of A .

Accordingly, if $(a, b) \in A \times A$ and $(b, c) \in A \times A$ then $(a, c) \in A \times A$ as well.

EXERCISE:

Let $A = \{0, 1, 2\}$ and

$R = \{(0,2), (1,1), (2,0)\}$ be a relation on A .

1. Is R reflexive? Symmetric? Transitive?
2. Which ordered pairs are needed in R to make it a reflexive and transitive relation.

SOLUTION:

1. R is not reflexive, since $0 \in A$ but $(0, 0) \notin R$ and also $2 \in A$ but $(2, 2) \notin R$.

R is clearly symmetric.

R is not transitive, since $(0, 2) \in R$ & $(2, 0) \in R$ but $(0, 0) \notin R$.

2. For R to be reflexive, it must contain ordered pairs $(0,0)$ and $(2,2)$.

For R to be transitive,

we note $(0,2)$ and $(2,0) \in R$ but $(0,0) \notin R$.

Also $(2,0)$ and $(0,2) \in R$ but $(2,2) \notin R$.

Hence $(0,0)$ and $(2,2)$. Are needed in R to make it a transitive relation.

EXERCISE:

Define a relation L on the set of real numbers \mathbf{R} be defined as follows:

for all $x, y \in \mathbf{R}$, $x L y \Leftrightarrow x < y$.

- a. Is L reflexive?
- b. Is L symmetric?
- c. Is L transitive?

SOLUTION:

- a. L is not reflexive, because $x \not\prec x$ for any real number x .
(e.g. $1 \not\prec 1$)

- b. L is not symmetric, because for all $x, y \in \mathbf{R}$, if $x < y$ then $y \not\prec x$
(e.g. $0 < 1$ but $1 \not\prec 0$)

- c. L is transitive, because for all, $x, y, z \in \mathbf{R}$, if $x < y$ and $y < z$, then $x < z$.

(by transitive law of order of real numbers).

EXERCISE:

Define a relation R on the set of positive integers Z^+ as follows:

for all $a, b \in Z^+$, $a R b$ iff $a \times b$ is odd.

Determine whether the relation is

- a. reflexive b. symmetric c. transitive

SOLUTION:

Firstly, recall that the product of two positive integers is odd if and only if both of them are odd.

a. reflexive

R is not reflexive, because $2 \in Z^+$ but $2 R 2$ for $2 \times 2 = 4$ which is not odd.

b. symmetric

R is symmetric, because
if $a R b$ then $a \times b$ is odd or equivalently $b \times a$ is odd
($b \times a = a \times b$) $\Rightarrow b R a$.

c. transitive

R is transitive, because if $a R b$ then $a \times b$ is odd
 \Rightarrow both "a" and "b" are odd. Also $b R c$ means $b \times c$ is odd
 \Rightarrow both "b" and "c" are odd.

Now if $a R b$ and $b R c$, then all of a, b, c are odd and so $a \times c$ is odd. Consequently $a R c$.

EXERCISE:

Let "D" be the "divides" relation on Z defined as:

for all $m, n \in Z$, $m D n \Leftrightarrow m|n$

Determine whether D is reflexive, symmetric or transitive. Justify your answer.

SOLUTION:

Reflexive

Let $m \in Z$, since every integer divides itself so $m|m$
 $\forall m \in Z$ therefore $m D m \quad \forall m \in Z$
Accordingly D is reflexive

Symmetric

Let $m, n \in Z$ and suppose $m D n$.
By definition of D , this means $m|n$ (i.e. = an integer)
Clearly, then it is not necessary that $n|m$ = an integer.
Accordingly, if $m D n$ then $n D m$, $\forall m, n \in Z$
Hence D is not symmetric.

Transitive

Let $m, n, p \in Z$ and suppose $m D n$ and $n D p$.
Now $m D n \Rightarrow m|n \Rightarrow \frac{n}{m} = \text{an integer}$.
Also $n D p \Rightarrow n|p \Rightarrow \frac{p}{n} = \text{an integer}$.

We note $\frac{p}{m} = \left(\frac{p}{n}\right) * \left(\frac{n}{m}\right) = (\text{an int}) * (\text{an int})$

$= \text{an int}$
 $\Rightarrow m|p$ and so mDp
 Thus if mDn and nDp then $mDp \forall m, n, p \in Z$
 Hence D is transitive.

EXERCISE:

Let A be the set of people living in the world today. A binary relation R is defined on A as follows:
 for all $p, q \in A$, $pRq \Leftrightarrow p$ has the same first name as q .
 Determine whether the relation R is reflexive, symmetric and/or transitive.

SOLUTION:**a. Reflexive**

Since every person has the same first name as his/her self.
 Hence for all $p \in A$, pRp . Thus, R is reflexive.

b. Symmetric:

Let $p, q \in A$ and suppose pRq .
 $\Leftrightarrow p$ has the same first name as q .
 $\Leftrightarrow q$ has the same first name as p .
 $\Leftrightarrow qRp$
 Thus if pRq then $qRp \forall p, q \in A$.
 $\Rightarrow R$ is symmetric.

a. Transitive

Let $p, q, s \in A$ and suppose pRq and qRr .
 Now $pRq \Leftrightarrow p$ has the same first name as q
 and $qRr \Leftrightarrow q$ has the same first name as r .
 Consequently, p has the same first name as r .
 $\Leftrightarrow pRr$
 Thus, if pRq and qRr then $pRr, \forall p, q, r \in A$.
 Hence R is transitive.

EQUIVALENCE RELATION:

Let A be a non-empty set and R a binary relation on A . R is an equivalence relation if, and only if, R is reflexive, symmetric, and transitive.

EXAMPLE:

Let $A = \{1, 2, 3, 4\}$ and
 $R = \{(1,1), (2,2), (2,4), (3,3), (4,2), (4,4)\}$
 be a binary relation on A .

Note that R is reflexive, symmetric and transitive, hence an equivalence relation.

CONGRUENCES:

Let m and n be integers and d be a positive integer. The notation

$m \equiv n \pmod{d}$ means that

$d \mid (m - n)$ { d divides m minus n }. There exists an integer k such that
 $(m - n) = d \cdot k$

$$\begin{aligned}(m - n) + (n - p) &= 3r + 3s \\ \Rightarrow m - p &= 3(r + s), \text{ where } r + s \in \mathbb{Z} \\ \Rightarrow 3 &|(m - p) \\ \Rightarrow m &\equiv p \pmod{3} \Leftrightarrow m R p\end{aligned}$$

Hence R is transitive. R being reflexive, symmetric and transitive, is an equivalence relation.

Lecture No.13 Matrix representation of relations

EXERCISE:

Suppose R and S are binary relations on a set A.

- If R and S are reflexive, is $R \cap S$ reflexive?
- If R and S are symmetric, is $R \cap S$ symmetric?
- If R and S are transitive, is $R \cap S$ transitive?

SOLUTION:

a. $R \cap S$ is reflexive:

Suppose R and S are reflexive.

Then by definition of reflexive relation

$$\forall a \in A (a,a) \in R \text{ and } (a,a) \in S$$

$$\Rightarrow \forall a \in A (a,a) \in R \cap S$$

(by definition of intersection)

Accordingly, $R \cap S$ is reflexive.

b. $R \cap S$ is symmetric.

Suppose R and S are symmetric.

To prove $R \cap S$ is symmetric we need to show that

$$\forall a, b \in A, \text{ if } (a,b) \in R \cap S \text{ then } (b,a) \in R \cap S.$$

Suppose $(a,b) \in R \cap S$.

$$\Rightarrow (a,b) \in R \text{ and } (a,b) \in S$$

(by the definition of Intersection of two sets)

Since R is symmetric, therefore if $(a,b) \in R$ then

$(b,a) \in R$. Similarly S is symmetric, so if $(a,b) \in S$ then $(b,a) \in S$.

Thus $(b,a) \in R$ and $(b,a) \in S$

$$\Rightarrow (b,a) \in R \cap S \quad (\text{by definition of intersection})$$

Accordingly, $R \cap S$ is symmetric.

c. $R \cap S$ is transitive.

Suppose R and S are transitive.

To prove $R \cap S$ is transitive we must show that

$$\forall a,b,c, \in A, \text{ if } (a,b) \in R \cap S \text{ and } (b,c) \in R \cap S$$

then $(a,c) \in R \cap S$.

Suppose $(a,b) \in R \cap S$ and $(b,c) \in R \cap S$

$$\Rightarrow (a,b) \in R \text{ and } (a,b) \in S \text{ and } (b,c) \in R \text{ and } (b,c) \in S$$

Since R is transitive, therefore

if $(a,b) \in R$ and $(b,c) \in R$ then $(a,c) \in R$.

Also S is transitive, so $(a,c) \in S$

Hence we conclude that $(a,c) \in R$ and $(a,c) \in S$

and so $(a,c) \in R \cap S$ (by definition of intersection)

Accordingly, $R \cap S$ is transitive.

EXAMPLE:

Let $A = \{1,2,3,4\}$
 and let R and S be transitive binary relations on A defined as:
 $R = \{(1,2), (1,3), (2,2), (3,3), (4,2), (4,3)\}$
 and $S = \{(2,1), (2,4), (3,3)\}$
 Then $R \cup S = \{(1,2), (1,3), (2,1), (2,2), (2,4), (3,3), (4,2), (4,3)\}$
 We note $(1,2)$ and $(2,1) \in R \cup S$, but $(1,1) \notin R \cup S$
 Hence $R \cup S$ is not transitive.

IRREFLEXIVE RELATION:

Let R be a binary relation on a set A . R is irreflexive iff for all $a \in A, (a,a) \notin R$.
 That is, R is irreflexive if no element in A is related to itself by R .

REMARK:

R is not irreflexive iff there is an element $a \in A$ such that $(a,a) \in R$.

EXAMPLE:

Let $A = \{1,2,3,4\}$ and define the following relations on A :
 $R_1 = \{(1,3), (1,4), (2,3), (2,4), (3,1), (3,4)\}$
 $R_2 = \{(1,1), (1,2), (2,1), (2,2), (3,3), (4,4)\}$
 $R_3 = \{(1,2), (2,3), (3,3), (3,4)\}$
 Then R_1 is irreflexive since no element of A is related to itself in R_1 . i.e.
 $(1,1) \notin R_1, (2,2) \notin R_1, (3,3) \notin R_1, (4,4) \notin R_1$
 R_2 is not irreflexive, since all elements of A are related to themselves in R_2
 R_3 is not irreflexive since $(3,3) \in R_3$. Note that R_3 is not reflexive.

NOTE:

A relation may be neither reflexive nor irreflexive.

DIRECTED GRAPH OF AN IRREFLEXIVE RELATION:

Let R be an **irreflexive** relation on a set A . Then by definition, no element of A is related to itself by R . Accordingly, there is no loop at each point of A in the directed graph of R .

EXAMPLE:

Let $A = \{1,2,3\}$
 and $R = \{(1,3), (2,1), (2,3), (3,2)\}$ be represented by the directed graph.

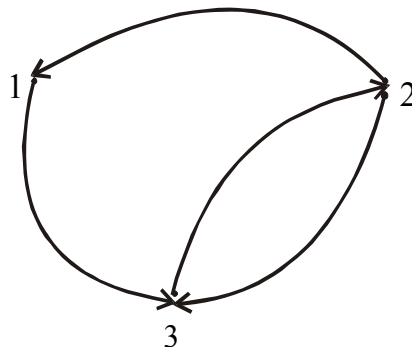
**MATRIX REPRESENTATION OF AN IRREFLEXIVE RELATION**

Let R be an irreflexive relation on a set A . Then by definition, no element of A is related to itself by R .

DIRECTED GRAPH OF AN ANTISYMMETRIC RELATION:

Let R be an anti-symmetric relation on a set A . Then by definition, no two distinct elements of A are related to each other.

Accordingly, there is no pair of arrows between two distinct elements of A in the directed graph of R .

EXAMPLE:

Let $A = \{1,2,3\}$ And R be the relation defined on A is $R = \{(1,1), (1,2), (2,3), (3,1)\}$. Thus R is represented by the directed graph as

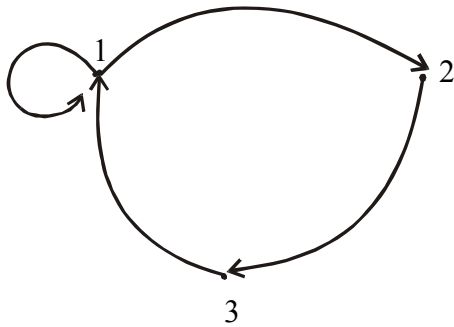

R is anti-symmetric, since there is no pair of arrows between two distinct points in A .

MATRIX REPRESENTATION OF AN ANTISYMMETRIC RELATION:

Let R be an anti-symmetric relation on a set

$A = \{a_1, a_2, \dots, a_n\}$. Then if $(a_i, a_j) \in R$ for $i \neq j$ then $(a_j, a_i) \notin R$.

Thus in the matrix representation of R there is a 1 in the i th row and j th column iff the j th row and i th column contains 0 vice versa.

EXAMPLE:

Let $A = \{1,2,3\}$ and a relation $R = \{(1,1), (1,2), (2,3), (3,1)\}$ on A be represented by the matrix.

$$M = \begin{matrix} & \begin{matrix} 1 & 2 & 3 \end{matrix} \\ \begin{matrix} 1 \\ 2 \\ 3 \end{matrix} & \begin{bmatrix} 1 & 1 & 0 \\ 0 & 0 & 1 \\ 1 & 0 & 0 \end{bmatrix} \end{matrix}$$

Then R is anti-symmetric as clear by the form of matrix M

PARTIAL ORDER RELATION:

Let R be a binary relation defined on a set A . R is a partial order relation, if and only if, R is **reflexive**, **antisymmetric**, and **transitive**. The set A together with a partial ordering R is called a **partially ordered set** or **poset**.

EXAMPLE:

Let R be the set of real numbers and define the "less than or equal to", on R as follows:

$$\text{for all real numbers } x \text{ and } y \text{ in } R. x \leq y \Leftrightarrow x < y \text{ or } x = y$$

Show that \leq is a partial order relation.

SOLUTION:

\leq is reflexive

For \leq to be reflexive means that $x \leq x$ for all $x \in R$

But $x \leq x$ means that $x < x$ or $x = x$ and $x = x$ is always true.

Hence under this relation every element is related to itself.

\leq is anti-symmetric.

For \leq to be anti-symmetric means that

$\forall x, y \in \mathbb{R}$, if $x \leq y$ and $y \leq x$, then $x = y$.

This follows from the definition of \leq and the trichotomy property, which says that

“given any real numbers x and y , exactly one of the following holds:

$x < y$ or $x = y$ or $x > y$ ”

 \leq is transitive

For \leq to be transitive means that

$\forall x, y, z \in \mathbb{R}$, if $x \leq y$ and $y \leq z$ then $x \leq z$.

This follows from the definition of \leq and the transitive property of order of real numbers, which says that “given any real numbers x , y and z ,

if $x < y$ and $y < z$ then $x < z$ ”

Thus \leq being reflexive, anti-symmetric and transitive is a partial order relation on \mathbb{R} .

EXERCISE:

Let A be a non-empty set and $P(A)$ the power set of A .

Define the “subset” relation, \subseteq , as follows:

for all $X, Y \in P(A)$, $X \subseteq Y \Leftrightarrow \forall x$, iff $x \in X$ then $x \in Y$.

Show that \subseteq is a partial order relation.

SOLUTION:**1. \subseteq is reflexive**

Let $X \in P(A)$. Since every set is a subset of itself, therefore

$X \subseteq X$, $\forall X \in P(A)$.

Accordingly \subseteq is reflexive.

2. \subseteq is anti-symmetric

Let $X, Y \in P(A)$ and suppose $X \subseteq Y$ and $Y \subseteq X$. Then by definition of equality of two sets it follows that $X = Y$.

Accordingly, \subseteq is anti-symmetric.

3. \subseteq is transitive

Let $X, Y, Z \in P(A)$ and suppose $X \subseteq Y$ and $Y \subseteq Z$. Then by the transitive property of subsets “if $U \subseteq V$ and $V \subseteq W$ then $U \subseteq W$ ” it follows $X \subseteq Z$.

Accordingly \subseteq is transitive.

EXERCISE:

Let “ $|$ ” be the “divides” relation on a set A of positive integers. That is, for all $a, b \in A$, $a|b \Leftrightarrow b = k \cdot a$ for some integer k .

Prove that $|$ is a partial order relation on A .

SOLUTION:**1. “ $|$ ” is reflexive.** [We must show that, $\forall a \in A$, $a|a$]

Suppose $a \in A$. Then $a = 1 \cdot a$ and so $a|a$ by definition of divisibility.

2. “ $|$ ” is anti-symmetric

[We must show that for all $a, b \in A$, if $a|b$ and $b|a$ then $a=b$]

Suppose $a|b$ and $b|a$

By definition of divides there are integers k_1 , and k_2 such that

$$b = k_1 \cdot a \quad \text{and} \quad a = k_2 \cdot b$$

Now $b = k_1 \cdot a$

$$= k_1 \cdot (k_2 \cdot b) \quad (\text{by substitution})$$

$$= (k_1 \cdot k_2) \cdot b$$

Dividing both sides by b gives

$$1 = k_1 \cdot k_2$$

Since $a, b \in A$, where A is the set of positive integers, so the equations

$$b = k_1 \cdot a \quad \text{and} \quad a = k_2 \cdot b$$

implies that k_1 and k_2 are both positive integers. Now the equation

$$k_1 \cdot k_2 = 1$$

can hold only when $k_1 = k_2 = 1$

Thus $a = k_2 \cdot b = 1 \cdot b = b$ i.e., $a = b$

3. “|” is transitive

[We must show that $\forall a, b, c \in A$ if $a|b$ and $b|c$ then $a|c$]

Suppose $a|b$ and $b|c$

By definition of divides, there are integers k_1 and k_2 such that

$$b = k_1 \cdot a \quad \text{and} \quad c = k_2 \cdot b$$

Now $c = k_2 \cdot b$

$$= k_2 \cdot (k_1 \cdot a) \quad (\text{by substitution})$$

$$= (k_2 \cdot k_1) \cdot a \quad (\text{by associative law under multiplication})$$

$$= k_3 \cdot a \quad \text{where } k_3 = k_2 \cdot k_1 \text{ is an integer}$$

$$\Rightarrow a|c \quad \text{by definition of divides}$$

Thus “|” is a partial order relation on A .

EXERCISE:

Let “ R ” be the relation defined on the set of integers Z as follows:

$$\text{for all } a, b \in Z, aRb \text{ iff } b = a^r \text{ for some positive integer } r.$$

Show that R is a partial order on Z .

SOLUTION:

1. Since for every integer “ a ” there exist a positive integer 1 such that

$$a = a^1 \quad \forall a \in Z$$

Thus R is reflexive.

2. Let $a, b \in Z$ and suppose aRb and bRa . Then there are positive integers r and s such that

$$b = a^r \quad \text{and} \quad a = b^s$$

$$\begin{aligned} \text{Now, } a &= b^s \\ &= (a^r)^s && \text{by substitution} \\ &= a^{rs} \end{aligned}$$

$$\Rightarrow rs = 1$$

Since r and s are positive integers, so this equation can hold if, and only if, $r = 1$ and $s = 1$

$$\text{and then } a = b^s = b^1 = b \quad \text{i.e., } a = b$$

Thus R is anti-symmetric.

3. Let $a, b, c \in Z$ and suppose aRb and bRc .

Then there are positive integers r and s such that

$$b = a^r \quad \text{and} \quad c = b^s$$

Now $c = b^r$

$$= (a^r)^s \quad (\text{by substitution})$$

$$= a^{rs} = a^t \quad (\text{where } t = rs \text{ is also a positive integer})$$

Hence by definition of R , aRc . Therefore, R is transitive.

Accordingly, R is a **partial order** relation on Z .

Lecture No.14 Inverse of relations

INVERSE OF A RELATION:

Let R be a relation from A to B . The inverse relation R^{-1} from B to A is defined as:

$$R^{-1} = \{(b,a) \in B \times A \mid (a,b) \in R\}$$

More simply, the inverse relation R^{-1} of R is obtained by interchanging the elements of all the ordered pairs in R .

EXAMPLE:

Let $A = \{2, 3, 4\}$ and $B = \{2, 6, 8\}$ and let R be the “divides” relation from A to B . i.e. for all $(a,b) \in A \times B$, $a R b \Leftrightarrow a \mid b$ (a divides b)
Then $R = \{(2,2), (2,6), (2,8), (3,6), (4,8)\}$ and $R^{-1} = \{(2,2), (6,2), (8,2), (6,3), (8,4)\}$
In words, R^{-1} may be defined as:

for all $(b,a) \in B \times A$, $b R^{-1} a \Leftrightarrow b$ is a multiple of a .

ARROW DIAGRAM OF AN INVERSE RELATION:

The relation $R = \{(2,2), (2,6), (2,8), (3,6), (4,8)\}$ is represented by the arrow diagram.

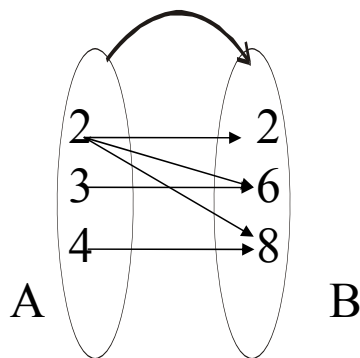

Then inverse of the above relation can be obtained simply changing the directions of the arrows and hence the diagram is

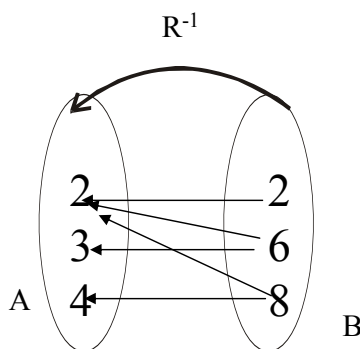

MATRIX REPRESENTATION OF INVERSE RELATION:

The relation $R = \{(2, 2), (2, 6), (2, 8), (3, 6), (4, 8)\}$ from $A = \{2, 3, 4\}$ to

$B = \{2, 6, 8\}$ is defined by the matrix M below:

$$M = \begin{matrix} & \begin{matrix} 2 & 6 & 8 \end{matrix} \\ \begin{matrix} 2 \\ 3 \\ 4 \end{matrix} & \begin{bmatrix} 1 & 1 & 1 \\ 0 & 1 & 0 \\ 0 & 0 & 1 \end{bmatrix} \end{matrix} \qquad M^t = \begin{matrix} & \begin{matrix} 2 & 3 & 4 \end{matrix} \\ \begin{matrix} 2 \\ 6 \\ 8 \end{matrix} & \begin{bmatrix} 1 & 0 & 0 \\ 1 & 1 & 0 \\ 1 & 0 & 1 \end{bmatrix} \end{matrix}$$

The matrix representation of inverse relation R^{-1} is obtained by simply taking its transpose. (i.e., changing rows by columns and columns by rows). Hence R^{-1} is represented by M^t as shown.

EXERCISE:

Let R be a binary relation on a set A . Prove that:

- (i) If R is reflexive, then R^{-1} is reflexive.
- (ii) If R is symmetric, then R^{-1} is symmetric.
- (iii) If R is transitive, then R^{-1} is transitive.
- (iv) If R is antisymmetric, then R^{-1} is antisymmetric.

SOLUTION (i)

if R is reflexive, then R^{-1} is reflexive.

Suppose that the relation R on A is reflexive. By definition, $\forall a \in A, (a, a) \in R$. Since R^{-1} consists of exactly those ordered pairs which are obtained by interchanging the first and second element of ordered pairs in R , therefore, if $(a, a) \in R$ then $(a, a) \in R^{-1}$. Accordingly, $\forall a \in A, (a, a) \in R^{-1}$. Hence R^{-1} is reflexive as well.

SOLUTION (ii)

Suppose that the relation R on A is symmetric.

Let $(a, b) \in R^{-1}$ for $a, b \in A$. By definition of R^{-1} , $(b, a) \in R$. Since R is symmetric, therefore $(a, b) \in R$. But then by definition of R^{-1} , $(b, a) \in R^{-1}$.

We have thus shown that for all $a, b \in A$, if $(a, b) \in R^{-1}$ then $(b, a) \in R^{-1}$.

Accordingly R^{-1} is symmetric.

SOLUTION (iii)

Prove that if R is transitive, then R^{-1} is transitive.

Suppose that the relation R on A is transitive. Let $(a, b) \in R^{-1}$ and $(b, c) \in R^{-1}$. Then by definition of R^{-1} , $(b, a) \in R$ and $(c, b) \in R$. Now R is transitive, therefore if $(c, b) \in R$ and $(b, a) \in R$ then $(c, a) \in R$.

Again by definition of R^{-1} , we have $(a, c) \in R^{-1}$. We have thus shown that for all $a, b, c \in A$, if $(a, b) \in R^{-1}$ and $(b, c) \in R^{-1}$ then $(a, c) \in R^{-1}$.

Accordingly R^{-1} is transitive.

SOLUTION (iv)

Prove that if R is anti-symmetric. Then R^{-1} is anti-symmetric.

Suppose that relation R on A is anti-symmetric. Let $(a, b) \in R^{-1}$ and $(b, a) \in R^{-1}$. Then by definition of R^{-1} , $(b, a) \in R$ and $(a, b) \in R$. Since R is antisymmetric, so if $(a, b) \in R$ and $(b, a) \in R$ then $a = b$. Thus we have shown that if $(a, b) \in R^{-1}$ and $(b, a) \in R^{-1}$ then $a = b$.

Accordingly R^{-1} is antisymmetric.

EXERCISE:

Show that the relation R on a set A is symmetric if, and only if, $R = R^{-1}$.

SOLUTION:

Suppose the relation R on A is symmetric.

Let $(a,b) \in R$. Since R is symmetric, so $(b,a) \in R$. But by definition of R^{-1} if $(b,a) \in R$ then $(a,b) \in R^{-1}$. Since (a,b) is an arbitrary element of R , so

$$R \subseteq R^{-1} \dots\dots\dots(1)$$

Next, let $(c,d) \in R^{-1}$. By definition of R^{-1} $(d,c) \in R$. Since R is symmetric, so $(c,d) \in R$. Thus we have shown that if $(c,d) \in R^{-1}$ then $(c,d) \in R$. Hence

$$R^{-1} \subseteq R \dots\dots\dots(2)$$

By (1) and (2) it follows that $R = R^{-1}$.

Conversely

suppose $R = R^{-1}$.

We have to show that R is symmetric. Let $(a,b) \in R$.

Now by definition of R^{-1} $(b,a) \in R^{-1}$. Since $R = R^{-1}$, so $(b,a) \in R = R^{-1}$.

Thus we have shown that if $(a,b) \in R$ then $(b,a) \in R$.

Accordingly R is symmetric.

COMPLEMENTRY RELATION:

Let R be a relation from a set A to a set B . The complementary relation \bar{R} of R is the set of all those ordered pairs in $A \times B$ that do not belong to R .

Symbolically:

$$\bar{R} = A \times B - R = \{(a,b) \in A \times B \mid (a,b) \notin R\}$$

EXAMPLE:

Let $A = \{1,2,3\}$ and

$R = \{(1,1), (1,3), (2,2), (2,3), (3,1)\}$ be a relation on A

Then $\bar{R} = \{(1,2), (2,1), (3,2), (3,3)\}$

EXERCISE:

Let R be the relation $\bar{R} = \{(a,b) \mid a < b\}$ on the set of integers. Find

a) \bar{R} b) R^{-1}

SOLUTION:

$$\begin{aligned} \text{a) } \bar{R} &= Z \times Z - R = \{(a,b) \mid a \not< b\} \\ &= \{(a,b) \mid a \geq b\} \end{aligned}$$

$$\text{b) } R^{-1} = \{(a,b) \mid a > b\}$$

EXERCISE:

Let R be a relation on a set A . Prove that R is reflexive iff \bar{R} is irreflexive

SOLUTION:

Suppose R is reflexive. Then by definition, for all $a \in A$, $(a,a) \in R$.

But then by definition of the complementary relation $(a,a) \notin \bar{R}$, $\forall a \in A$.

Accordingly \bar{R} is irreflexive.

Conversely

if \bar{R} is irreflexive, then $(a,a) \notin \bar{R}$, $\forall a \in A$.

Hence by definition of \bar{R} , it follows that $(a,a) \in R$, $\forall a \in A$.

Accordingly R is reflexive.

EXERCISE:

Suppose that R is a symmetric relation on a set A . Is \bar{R} also symmetric.

SOLUTION:

Let $(a,b) \in \bar{R}$. Then by definition of \bar{R} , $(a,b) \notin R$. Since R is symmetric, so

if $(a,b) \notin R$ then $(b,a) \notin R$.

{for $(b,a) \in R$ and $(a,b) \notin R$ will contradict the symmetry property of R }

Now $(b,a) \notin R \Rightarrow (b,a) \in \bar{R}$. Hence if $(a,b) \in \bar{R}$ then $(b,a) \in \bar{R}$

Thus \bar{R} is also symmetric.

COMPOSITE RELATION:

Let R be a relation from a set A to a set B and S a relation from B to a set C . The composite of R and S denoted SoR is the relation from A to C , consisting of ordered pairs (a,c) where $a \in A$, $c \in C$, and for which there exists an element $b \in B$ such that $(a,b) \in R$ and $(b,c) \in S$.

Symbolically:

$$SoR = \{(a,c) | a \in A, c \in C, \exists b \in B, (a,b) \in R \text{ and } (b,c) \in S\}$$

EXAMPLE:

Define $R = \{(a,1), (a,4), (b,3), (c,1), (c,4)\}$ as a relation from A to B and $S = \{(1,x), (2,x), (3,y), (3,z)\}$ be a relation from B to C .

Hence

$$SoR = \{(a,x), (b,y), (b,z), (c,x)\}$$

COMPOSITE RELATION FROM ARROW DIAGRAM:

Let $A = \{a,b,c\}$, $B = \{1,2,3,4\}$ and $C = \{x,y,z\}$. Define relation R from A to B and S from B to C by the following arrow diagram.

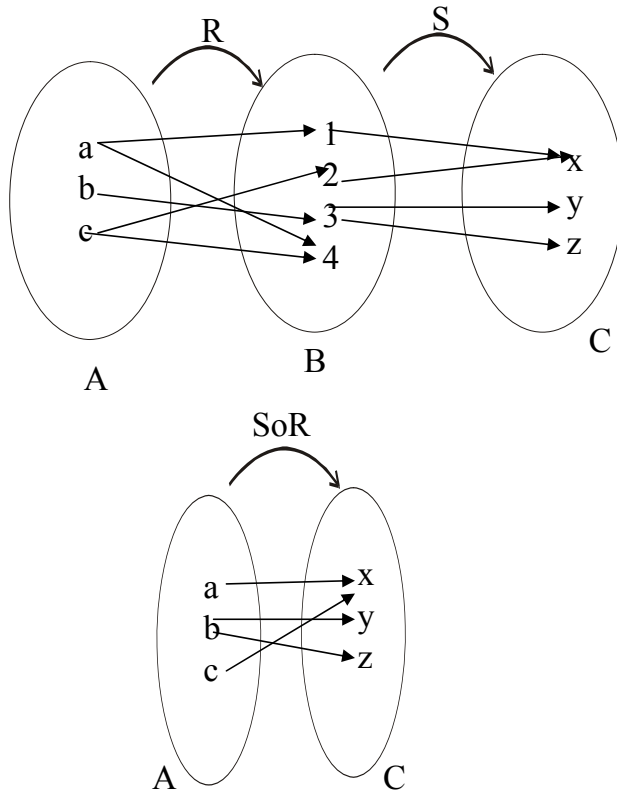

MATRIX REPRESENTATION OF COMPOSITE RELATION:

The matrix representation of the composite relation can be found using the Boolean product of the matrices for the relations. Thus if M_R and M_S are the matrices for relations R (from A to B) and S (from B to C), then

$$M_{SoR} = M_R \circ M_S$$

is the matrix for the composite relation SoR from A to C .

	BOOLEAN ADDITION		BOOLEAN MULTIPLICATION
a.	$1 + 1 = 1$	a.	$1 \cdot 1 = 1$
b.	$1 + 0 = 1$	b.	$1 \cdot 0 = 0$
c.	$0 + 0 = 0$	c.	$0 \cdot 0 = 0$

EXERCISE:

Find the matrix representing the relations SoR and RoS where the matrices representing R and S are

$$M_R = \begin{bmatrix} 1 & 0 & 1 \\ 1 & 1 & 0 \\ 0 & 0 & 0 \end{bmatrix} \quad M_S = \begin{bmatrix} 0 & 1 & 0 \\ 0 & 0 & 1 \\ 1 & 0 & 1 \end{bmatrix}$$

SOLUTION:

The matrix representation for SoR is

$$\begin{aligned}
 M_{SOR} = M_R O M_S &= \begin{bmatrix} 1 & 0 & 1 \\ 1 & 1 & 0 \\ 0 & 0 & 0 \end{bmatrix} \begin{bmatrix} 0 & 1 & 0 \\ 0 & 0 & 1 \\ 1 & 0 & 1 \end{bmatrix} \\
 &= \begin{bmatrix} 1 & 1 & 1 \\ 0 & 1 & 1 \\ 0 & 0 & 0 \end{bmatrix}
 \end{aligned}$$

The matrix representation for RoS is

$$\begin{aligned}
 M_{ROS} = M_S O M_R &= \begin{bmatrix} 0 & 1 & 0 \\ 0 & 0 & 1 \\ 1 & 0 & 1 \end{bmatrix} \begin{bmatrix} 1 & 0 & 1 \\ 1 & 1 & 0 \\ 0 & 0 & 0 \end{bmatrix} \\
 &= \begin{bmatrix} 1 & 1 & 0 \\ 0 & 0 & 0 \\ 1 & 0 & 1 \end{bmatrix}
 \end{aligned}$$

EXERCISE:

Let R and S be reflexive relations on a set A. Prove SoR is reflexive.

SOLUTION:

Since R and S are reflexive relations on A, so
 $\forall a \in A, (a,a) \in R$ and $(a,a) \in S$
 and by definition of the composite relation SoR, it is clear that
 $(a,a) \in \text{SoR} \forall a \in A$.
 Accordingly SoR is also reflexive.

Lecture No.15 Functions

RELATIONS AND FUNCTIONS:

A function **F** from a set **X** to a set **Y** is a relation from **X** to **Y** that satisfies the following two properties

1. For every element x in X , there is an element y in Y such that $(x,y) \in F$.
In other words every element of X is the first element of some ordered pair of F .
2. For all elements x in X and y and z in Y , if $(x,y) \in F$ and $(x,z) \in F$, then $y = z$
In other words no two distinct ordered pairs in F have the same first element.

EXERCISE:

Which of the relations define functions from $X = \{2,4,5\}$ to $Y = \{1,2,4,6\}$.

- a. $R_1 = \{(2,4), (4,1)\}$
- b. $R_2 = \{(2,4), (4,1), (4,2), (5,6)\}$
- c. $R_3 = \{(2,4), (4,1), (5,6)\}$

SOLUTION :

- a. R_1 is not a function, because $5 \in X$ does not appear as the first element in any ordered pair in R_1 .
- b. R_2 is not a function, because the ordered pairs $(4,1)$ and $(4,2)$ have the same first element but different second elements.
- c. R_3 defines a function because it satisfy both the conditions of the function that is every element of X is the first element of some order pair and there is no pair which has the same first order pair but different second order pair.

EXERCISE:

Let $A = \{4,5,6\}$ and $B = \{5,6\}$ and define binary relations R and S from A to B as follows:

for all $(x,y) \in A \times B$, $(x,y) \in R \Leftrightarrow x \geq y$
for all $(x,y) \in A \times B$, $xSy \Leftrightarrow 2|(x-y)$

- a. Represent R and S as a set of ordered pairs.
- b. Indicate whether R or S is a function

SOLUTION:

Since we are given the relation R contains those order pairs of $A \times B$ which has their first element greater or equal to the second Hence R contains the order pairs.

$$R = \{(5,5), (6,5), (6,6)\}$$

Similarly S is such a relation which consists of those order pairs for which the difference of first and second elements difference divisible by 2.

$$\text{Hence } S = \{(4,6), (5,5), (6,6)\}$$

- b. R is not a function because $4 \in A$ is not related to any element of B .

S clearly defines a function since each element of A is related to a unique element of B .

FUNCTION:

A function f from a set X to a set Y is a **relationship** between elements of X and elements of Y such that **each** element of X is related to a **unique** element of Y , and is denoted $f: X \rightarrow Y$. The set X is called the domain of f and Y is called the co-domain of f .

NOTE: The unique element y of Y that is related to x by f is denoted $f(x)$ and is called f of x , or the value of f at x , or the image of x under f

ARROW DIAGRAM OF A FUNCTION:

The definition of a function implies that the arrow diagram for a function f has the following two properties:

1. Every element of X has an arrow coming out of it
2. No two elements of X has two arrows coming out of it that point to two different elements of Y .

EXAMPLE:

Let $X = \{a,b,c\}$ and $Y = \{1,2,3,4\}$.

Define a function f from X to Y by the arrow diagram.

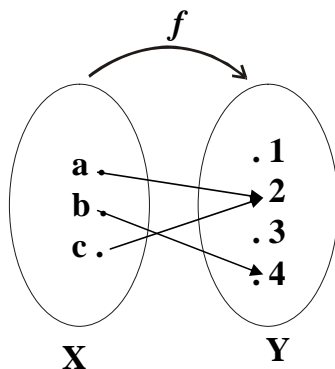

You can easily note that the above diagram satisfy the two conditions of a function hence a graph of the function.

Note that $f(a) = 2$, $f(b) = 4$, and $f(c) = 2$

FUNCTIONS AND NONFUNCTIONS:

Which of the arrow diagrams define functions from $X = \{2,4,5\}$ to $Y = \{1,2,4,6\}$.

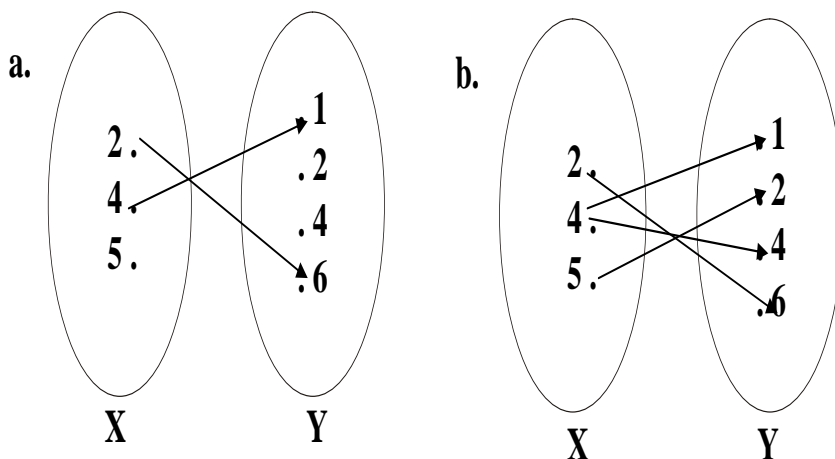

The relation given in the diagram (a) is **Not a function** because there is no arrow coming out of $5 \in X$ to any element of Y .

The relation in the diagram (b) is **Not a function**, because there are two arrows coming out of $4 \in X$. i.e., $4 \in X$ is not related to a unique element of Y .

RANGE OF A FUNCTION:

Let $f: X \rightarrow Y$. The range of f consists of those elements of Y that are image of elements of X .

Symbolically: **Range** of $f = \{y \in Y \mid y = f(x), \text{ for some } x \in X\}$

NOTE:

1. The range of a function f is always a subset of the co-domain of f .
2. The range of $f: X \rightarrow Y$ is also called the image of X under f .
3. When $y = f(x)$, then x is called the pre-image of y .
4. The set of all elements of X , that are related to some $y \in Y$ is called the inverse image of y .

EXERCISE:

Determine the range of the functions f, g, h from $X = \{2,4,5\}$ to $Y = \{1,2,4,6\}$ defined as:

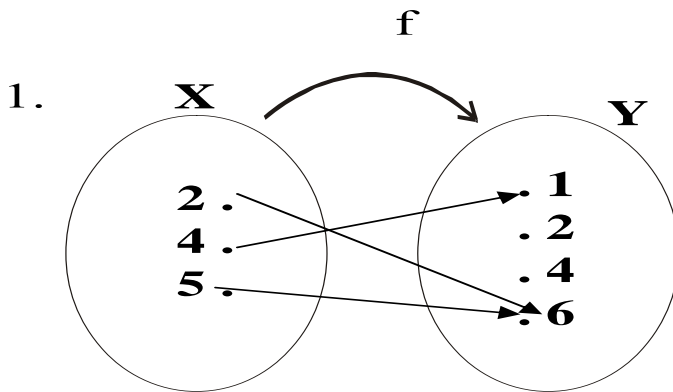

2. $g = \{(2,6), (4,2), (5,1)\}$
3. $h(2) = 4, \quad h(4) = 4, \quad h(5) = 1$

SOLUTION:

1. Range of $f = \{1, 6\}$
2. Range of $g = \{1, 2, 6\}$
3. Range of $h = \{1, 4\}$

GRAPH OF A FUNCTION:

Let f be a real-valued function of a real variable. i.e. $f: \mathbb{R} \rightarrow \mathbb{R}$. The graph of f is the set of all points (x,y) in the Cartesian coordinate plane with the property that x is in the domain of f and $y = f(x)$.

EXAMPLE:

We have to draw the graph of the function f given by the relation $y=x^2$ in order to draw the graph of the function we will first take some elements from the domain will see the image of them and then plot them on the graph as follows

Graph of $y = x^2$

x	y=f(x)
-3	9
-2	4
-1	1
0	0
+1	1
+2	4
+3	9

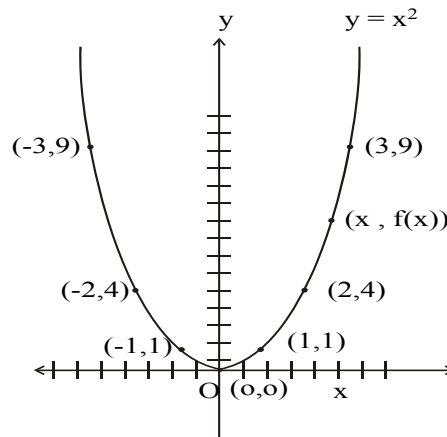

VERTICAL LINE TEST FOR THE GRAPH OF A FUNCTION:

For a graph to be the graph of a function, any given vertical line in its domain intersects the graph in at most one point.

EXAMPLE:

The graph of the relation $y = x^2$ on \mathbb{R} defines a function by vertical line test.

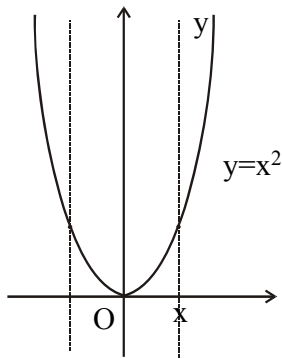

EXERCISE:

Define a binary relation P from \mathbb{R} to \mathbb{R} as follows:

for all real numbers x and y $(x, y) \in P \Leftrightarrow x = y^2$

Is P a function? Explain.

SOLUTION:

The graph of the relation $x = y^2$ is shown below. Since a vertical line intersects the graph at two points; the graph does not define a function.

x	Y
9	-3
4	-2
1	-1
0	0
1	1
4	2
9	3

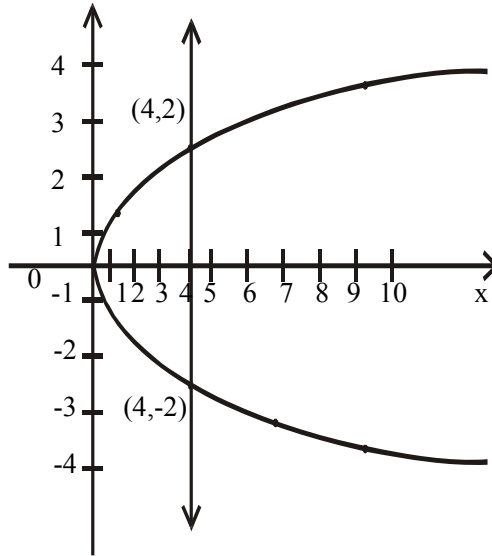

EXERCISE:

Find all functions from $X = \{a,b\}$ to $Y = \{u,v\}$

SOLUTION:

1.

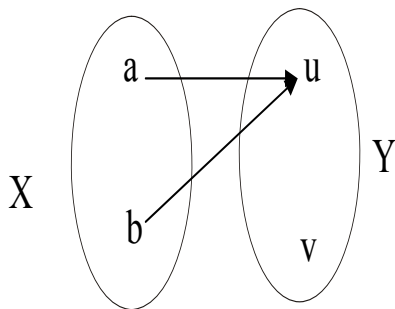

2.

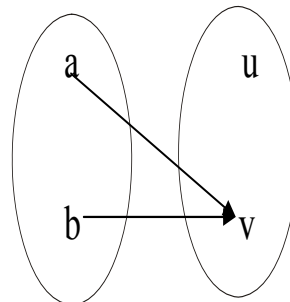

3.

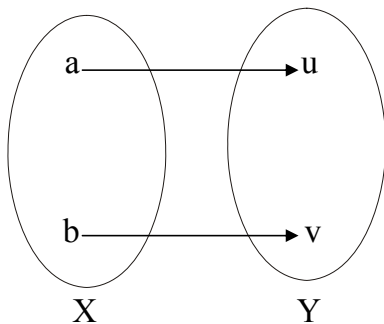

4.

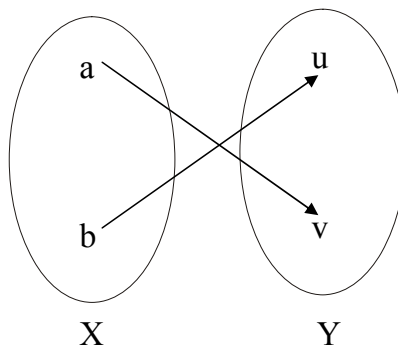

EXERCISE:

Find four binary relations from $X = \{a,b\}$ to $Y = \{u,v\}$ that are not functions.

SOLUTION:

The four relations are

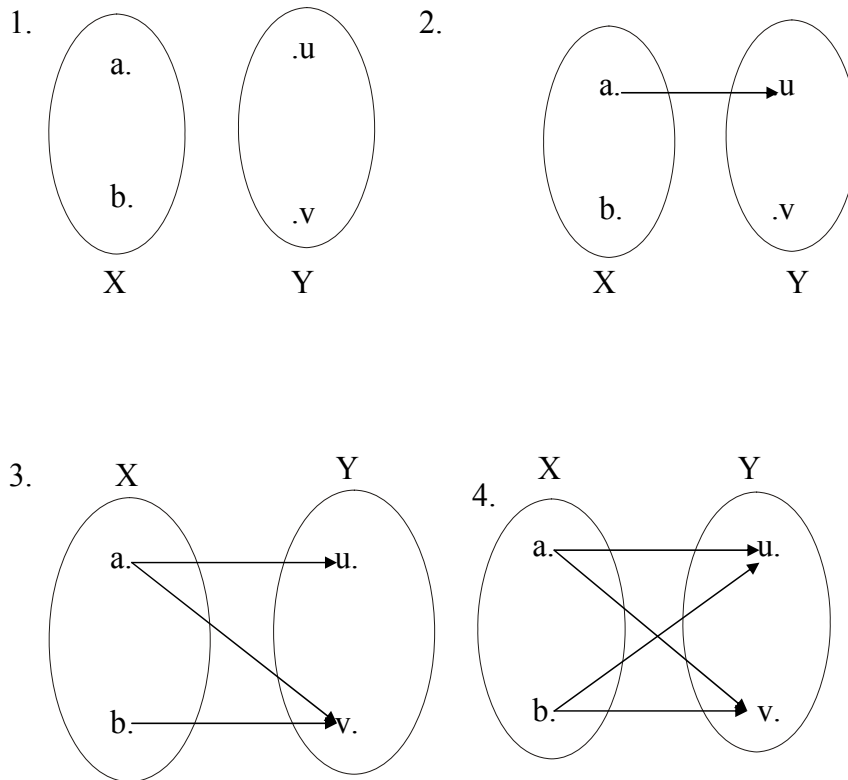
**EXERCISE:**

How many functions are there from a set with three elements to a set with four elements?

SOLUTION:

Let $X = \{x_1, x_2, x_3\}$ and $Y = \{y_1, y_2, y_3, y_4\}$

Then x_1 may be related to any of the four elements y_1, y_2, y_3, y_4 of Y . Hence there are 4 ways to relate x_1 in Y . Similarly x_2 may also be related to any one of the 4 elements in Y . Thus the total number of different ways to relate x_1 and x_2 to elements of Y are $4 \times 4 = 16$. Finally x_3 must also have its image in Y and again any one of the 4 elements y_1, y_2, y_3 or y_4 could be its image.

Therefore the total number of functions from X to Y are

$$4 \times 4 \times 4 = 4^3 = 64.$$

EXERCISE:

Suppose A is a set with m elements and B is a set with n elements.

1. How many binary relations are there from A to B ?
2. How many functions are there from A to B ?
3. What fraction of the binary relations from A to B are functions?

SOLUTION:

1. Number of elements in $A \times B = m.n$

Therefore, number of binary relations from A to $B =$

$$\text{Number of all subsets of } A \times B = 2^{mn}$$

2. Number of functions from A to $B = n.n.n. \dots .n$ (m times)
 $= n^m$

3. Fraction of binary relations that are functions $= n^m / 2^{mn}$

FUNCTIONS NOT WELL DEFINED:

Determine whether f is a function from Z to R if

$$a. \quad f(n) = \pm n \quad b. \quad f(n) = \frac{1}{n^2 - 4}$$

$$c. \quad f(n) = \sqrt{n} \quad d. \quad f(n) = \sqrt{n^2 + 1}$$

SOLUTION:

- f is not well defined since each integer n has two images $+n$ and $-n$
- f is not well defined since $f(2)$ and $f(-2)$ are not defined.
- f is not defined for $n < 0$ since f then results in imaginary values (not real)
- f is well defined because each integer has unique (one and only one) image in R under f .

EXERCISE:

Student C tries to define a function $h : Q \rightarrow Q$ by the rule. $h\left(\frac{m}{n}\right) = \frac{m^2}{n}$
for all integers m and n with $n \neq 0$

Students D claims that h is not well defined. Justify students D's claim.

SOLUTION:

The function h is well defined if each rational number has a unique (one and only one) image.

$$\text{Consider } \frac{1}{2} \in Q$$

$$h\left(\frac{1}{2}\right) = \frac{1^2}{2} = \frac{1}{2}$$

$$\text{Now } \frac{1}{2} = \frac{2}{4} \text{ and}$$

$$h\left(\frac{2}{4}\right) = \frac{2^2}{4} = \frac{4}{4} = 1$$

Hence an element of Q has more than one images under h . Accordingly h is not well defined.

REMARK:

A function $f: X \rightarrow Y$ is well defined *iff* $\forall x_1, x_2 \in X$, if $x_1 = x_2$ then $f(x_1) = f(x_2)$

EXERCISE:

Let $g: \mathbb{R} \rightarrow \mathbb{R}^+$ be defined by $g(x) = x^2 + 1$

1. Show that g is well defined.
2. Determine the domain, co-domain and range of g .

SOLUTION:**1. g is well defined:**

Let $x_1, x_2 \in \mathbb{R}$ and suppose $x_1 = x_2$

$$\Rightarrow x_1^2 = x_2^2 \quad (\text{squaring both sides})$$

$$\Rightarrow x_1^2 + 1 = x_2^2 + 1 \quad (\text{adding 1 on both sides})$$

$$\Rightarrow g(x_1) = g(x_2) \quad (\text{by definition of } g)$$

Thus if $x_1 = x_2$ then $g(x_1) = g(x_2)$. According $g: \mathbb{R} \rightarrow \mathbb{R}^+$ is well defined.

2. $g: \mathbb{R} \rightarrow \mathbb{R}^+$ defined by $g(x) = x^2 + 1$.

Domain of $g = \mathbb{R}$ (set of real numbers)

Co-domain of $g = \mathbb{R}^+$ (set of positive real numbers)

The range of g consists of those elements of \mathbb{R}^+ that appear as image points.

$$\text{Since } x^2 \geq 0 \quad \forall x \in \mathbb{R}$$

$$x^2 + 1 \geq 1 \quad \forall x \in \mathbb{R}$$

$$\text{i.e. } g(x) = x^2 + 1 \geq 1 \quad \forall x \in \mathbb{R}$$

Hence the range of g is all real number greater than or equal to 1, i.e., the internal $[1, \infty)$

IMAGE OF A SET:

Let $f: X \rightarrow Y$ is function and $A \subseteq X$.

The image of A under f is denoted and defined as:

$$f(A) = \{y \in Y \mid y = f(x), \text{ for some } x \text{ in } A\}$$

EXAMPLE:

Let $f: X \rightarrow Y$ be defined by the arrow diagram

Let $A = \{1, 2\}$ and $B = \{2, 3\}$ then

$f(A) = \{b\}$ and $f(B) = \{b, c\}$ under the function defined in the Diagram then we say that image set of A is $\{b\}$ and I mage set of B is $\{b, c\}$.

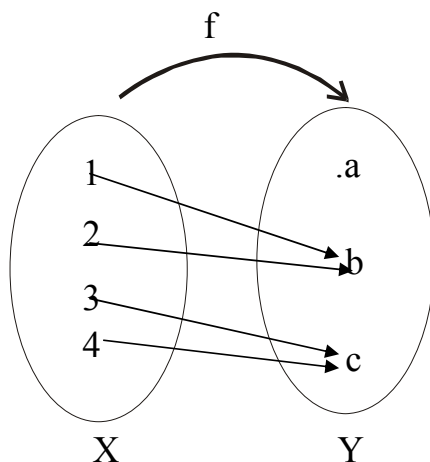

INVERSE IMAGE OF A SET:

Let $f: X \rightarrow Y$ is a function and $C \subseteq Y$. The inverse image of C under f is denoted and defined as:

$$f^{-1}(C) = \{x \in X \mid f(x) \in C\}$$

EXAMPLE:

Let $f: X \rightarrow Y$ be defined by the arrow diagram.

Let $C = \{a\}, D = \{b, c\}, E = \{d\}$ then

$$f^{-1}(C) = \{1, 2\},$$

$$f^{-1}(D) = \{3, 4\}, \text{ and}$$

$$f^{-1}(E) = \emptyset$$

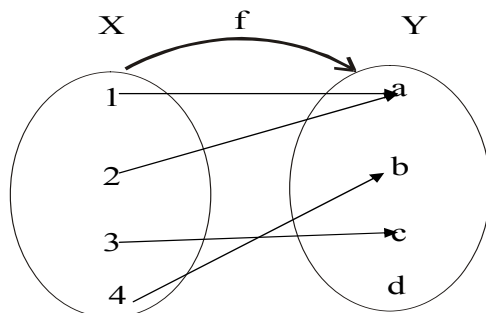
**SOME RESULTS:**

Let $f: X \rightarrow Y$ is a function. Let A and B be subsets of X and C and D be subsets of Y .

1. if $A \subseteq B$ then $f(A) \subseteq f(B)$
2. $f(A \cup B) = f(A) \cup f(B)$
3. $f(A \cap B) \subseteq f(A) \cap f(B)$
4. $f(A - B) \supseteq f(A) - f(B)$
5. if $C \subseteq D$, then $f^{-1}(C) \subseteq f^{-1}(D)$
6. $f^{-1}(C \cup D) = f^{-1}(C) \cup f^{-1}(D)$
7. $f^{-1}(C \cap D) = f^{-1}(C) \cap f^{-1}(D)$
8. $f^{-1}(C - D) = f^{-1}(C) - f^{-1}(D)$

BINARY OPERATIONS:

A binary operation “ $*$ ” defined on a set A assigns to each ordered pair (a, b) of elements of A , a uniquely determined element $a*b$ of A .

That is, a binary operation takes two elements of A and maps them to a third element of A .

EXAMPLE:

1. “ $+$ ” and “ \cdot ” are binary operations on the set of natural numbers N .
2. “ $-$ ” is not a binary operation on N .
3. “ $-$ ” is a binary operation on Z , the set of integers.
4. “ \div ” is a binary operation on the set of non-zero rational numbers $Q - \{0\}$, but not a binary operation on Z .

BINARY OPERATION AS FUNCTION:

A binary operation “ $*$ ” on a set A is a function from $A * A$ to A .

$$\text{i.e. } *: A \times A \rightarrow A.$$

Hence $*(a, b) = c$, where $a, b, c \in A$.

NOTE

$*(a, b)$ is more commonly written as $a*b$.

EXAMPLES:

1. The set operations union \cup , intersection \cap and set difference $-$, are binary operators on the power set $P(A)$ of any set A .
2. The logical connectives $\vee, \wedge, \rightarrow, \leftrightarrow$ are binary operations on the set $\{T, F\}$
3. The logic gates OR and AND are binary operations on $\{0,1\}$

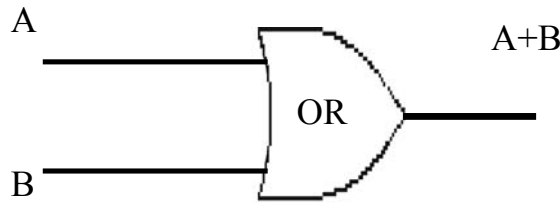

A	B	A+B
1	1	1
1	0	1
0	1	1
0	0	0

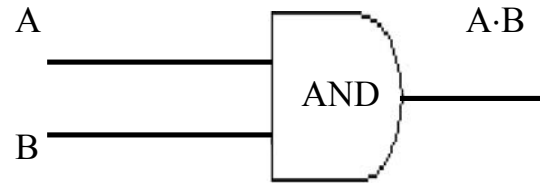

A	B	A·B
1	1	1
1	0	0
0	1	0
0	0	0

4. The logic gate NOT is a uninary operation on $\{0,1\}$

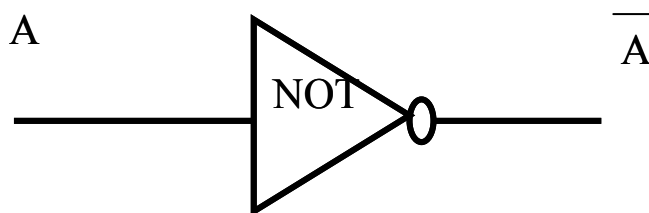

A	A
1	0
0	1

Lecture No.16 Types of functions

INJECTIVE FUNCTION

or

ONE-TO-ONE FUNCTION

Let $f: X \rightarrow Y$ be a function. f is injective or one-to-one if, and only if, $\forall x_1, x_2 \in X$, if $x_1 \neq x_2$ then $f(x_1) \neq f(x_2)$. That is, f is one-to-one if it maps distinct points of the domain into the distinct points of the co-domain.

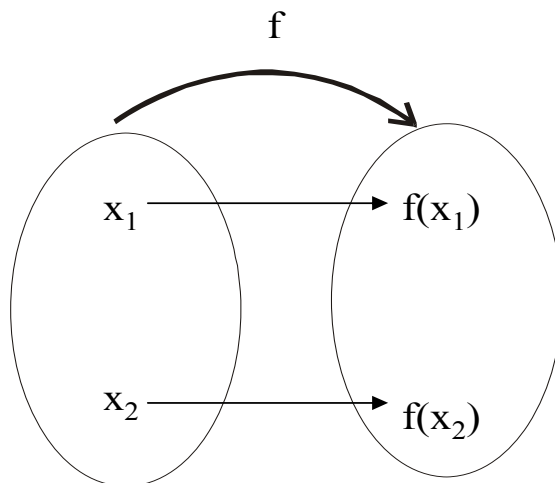

A one-to-one function separates points.

FUNCTION NOT ONE-TO-ONE:

A function $f: X \rightarrow Y$ is not one-to-one iff there exist elements x_1 and x_2 such that $x_1 \neq x_2$ but $f(x_1) = f(x_2)$. That is, if distinct elements x_1 and x_2 can be found in the domain of f then they have the same function value.

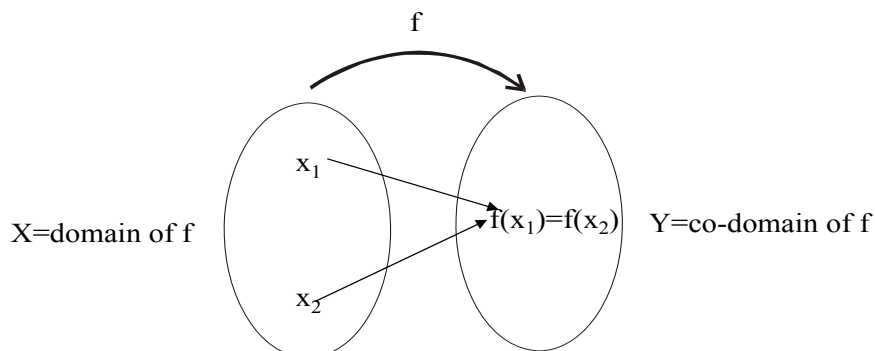

A function that is not one-to-one collapses points together.

EXAMPLE:

Which of the arrow diagrams define one-to-one functions?

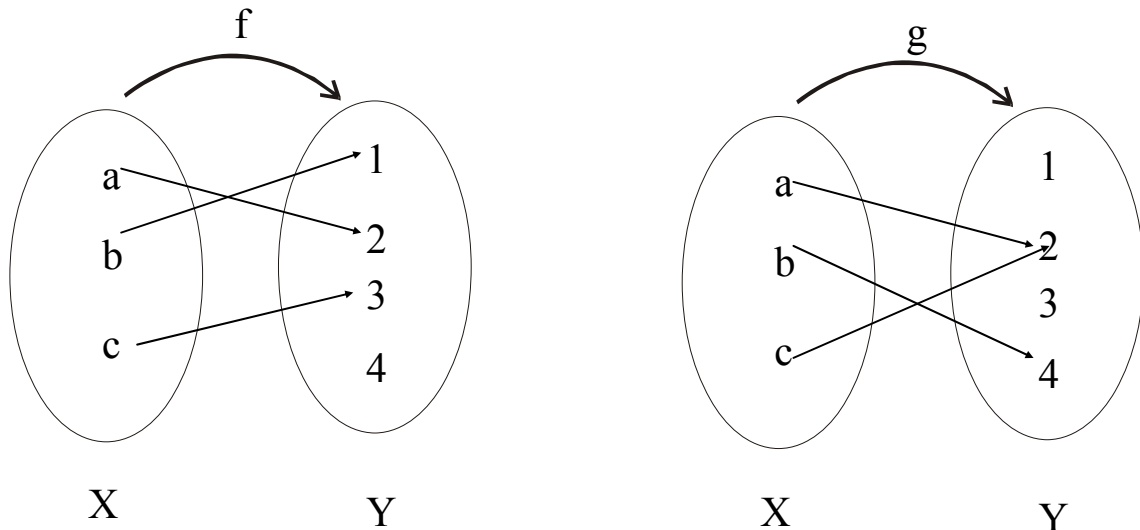
**SOLUTION:**

f is clearly one-to-one function, because no two different elements of X are mapped onto the same element of Y.

g is not one-to-one because the elements a and c are mapped onto the same element 2 of Y.

ALTERNATIVE DEFINITION FOR ONE-TO-ONE FUNCTION:

A function $f: X \rightarrow Y$ is one-to-one (1-1) iff $\forall x_1, x_2 \in X$, if $x_1 \neq x_2$ then $f(x_1) \neq f(x_2)$ (i.e distinct elements of 1st set have their distinct images in 2nd set)

The equivalent contra-positive statement for this implication is $\forall x_1, x_2 \in X$, if $f(x_1) = f(x_2)$, then $x_1 = x_2$

REMARK:

$f: X \rightarrow Y$ is not one-to-one iff $\exists x_1, x_2 \in X$ with $f(x_1) = f(x_2)$ but $x_1 \neq x_2$

EXAMPLE:

Define $f: \mathbb{R} \rightarrow \mathbb{R}$ by the rule $f(x) = 4x - 1$ for all $x \in \mathbb{R}$

Is f one-to-one? Prove or give a counter example.

SOLUTION:

Let $x_1, x_2 \in \mathbb{R}$ such that $f(x_1) = f(x_2)$

$$\Rightarrow 4x_1 - 1 = 4x_2 - 1 \quad (\text{by definition of } f)$$

$$\Rightarrow 4x_1 = 4x_2 \quad (\text{adding 1 to both sides})$$

$$\Rightarrow x_1 = x_2 \quad (\text{dividing both sides by 4})$$

Thus we have shown that if $f(x_1) = f(x_2)$ then $x_1 = x_2$

Therefore, f is one-to-one

EXAMPLE:

Define $g: \mathbb{Z} \rightarrow \mathbb{Z}$ by the rule $g(n) = n^2$ for all $n \in \mathbb{Z}$

Is g one-to-one? Prove or give a counter example.

SOLUTION:

Let $n_1, n_2 \in \mathbb{Z}$ and suppose $g(n_1) = g(n_2)$

$$\Rightarrow n_1^2 = n_2^2 \quad (\text{by definition of } g)$$

\Rightarrow either $n_1 = +n_2$ or $n_1 = -n_2$

Thus $g(n_1) = g(n_2)$ does not imply $n_1 = n_2$ always.

As a counter example, let $n_1 = 2$ and $n_2 = -2$.

Then

$$g(n_1) = g(2) = 2^2 = 4 \quad \text{and also} \quad g(n_2) = g(-2) = (-2)^2 = 4$$

Hence $g(2) = g(-2)$ where as $2 \neq -2$ and so g is not one-to-one.

EXERCISE:

Find all one-to-one functions from $X = \{a,b\}$ to $Y = \{u,v\}$

SOLUTION:

There are two one-to-one functions from X to Y defined by the arrow diagrams.

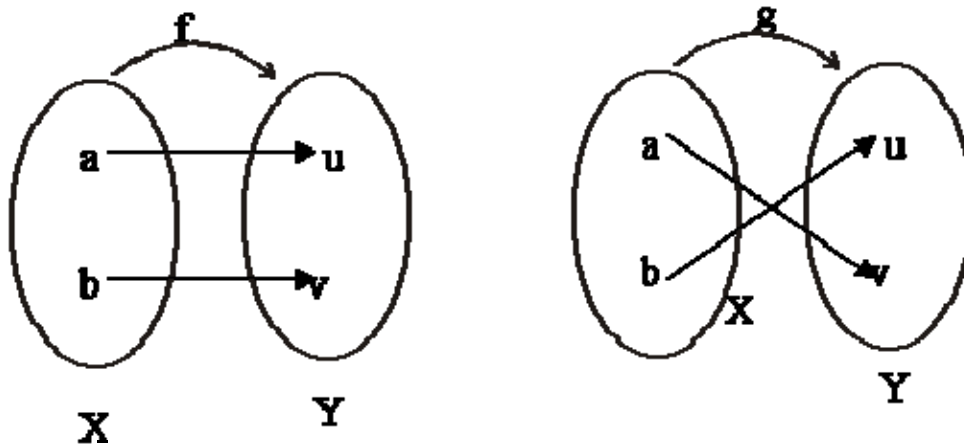

EXERCISE:

How many one-to-one functions are there from a set with three elements to a set with four elements.

SOLUTION:

Let $X = \{x_1, x_2, x_3\}$ and $Y = \{y_1, y_2, y_3, y_4\}$

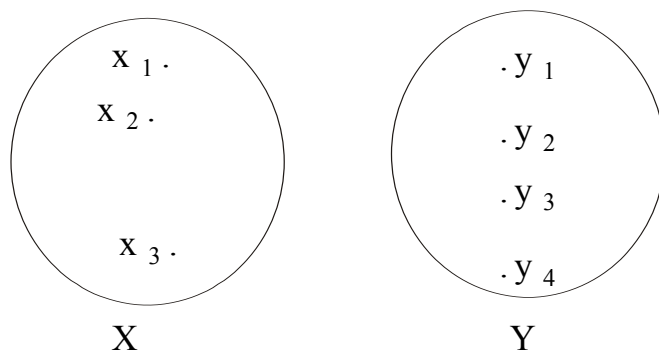

x_1 may be mapped to any of the 4 elements of Y . Then x_2 may be mapped to any of the remaining 3 elements of Y & finally x_3 may be mapped to any of the remaining 2 elements of Y .

Hence, total no. of one-to-one functions from X to Y are

$$4 \times 3 \times 2 = 24$$

EXERCISE:

How many one-to-one functions are there from a set with three elements to a set with two elements.

SOLUTION:

Let $X = \{x_1, x_2, x_3\}$ and $Y = \{y_1, y_2\}$

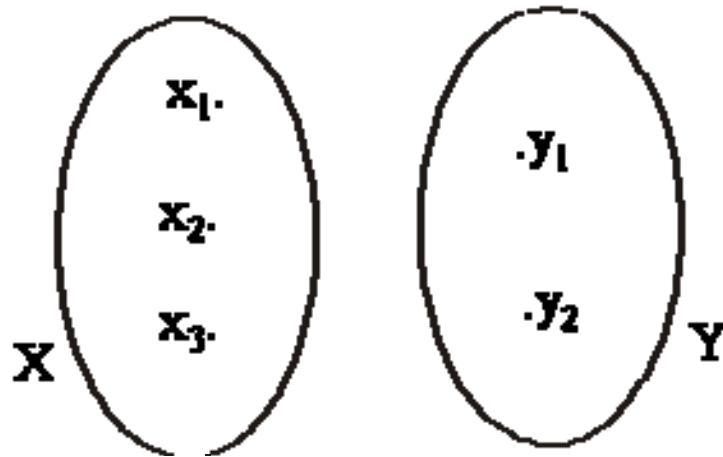

Two elements in X could be mapped to the two elements in Y separately. But there is no new element in Y to which the third element in X could be mapped. Accordingly there is no one-to-one function from a set with three elements to a set with two elements.

GRAPH OF ONE-TO-ONE FUNCTION:

A graph of a function f is one-to-one iff every horizontal line intersects the graph in at most one point.

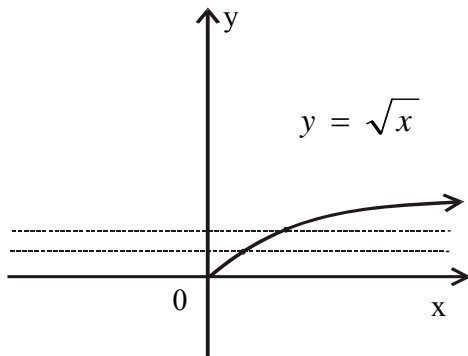
EXAMPLE:

ONE-TO-ONE FUNCTION
from \mathbb{R}^+ to \mathbb{R}

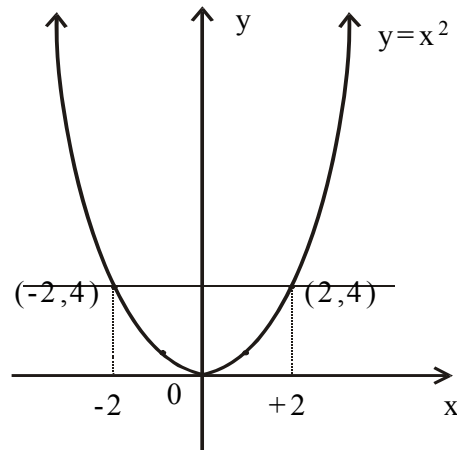

NOT ONE-TO-ONE FUNCTION
From \mathbb{R} to \mathbb{R}^+

SURJECTIVE FUNCTION or ONTO FUNCTION:

Let $f: X \rightarrow Y$ be a function. f is surjective or onto if, and only if, " $\forall y \in Y, \exists x \in X$ such that $f(x) = y$."

That is, f is onto if every element of its co-domain is the image of some element(s) of its domain. i.e., co-domain of $f =$ range of f

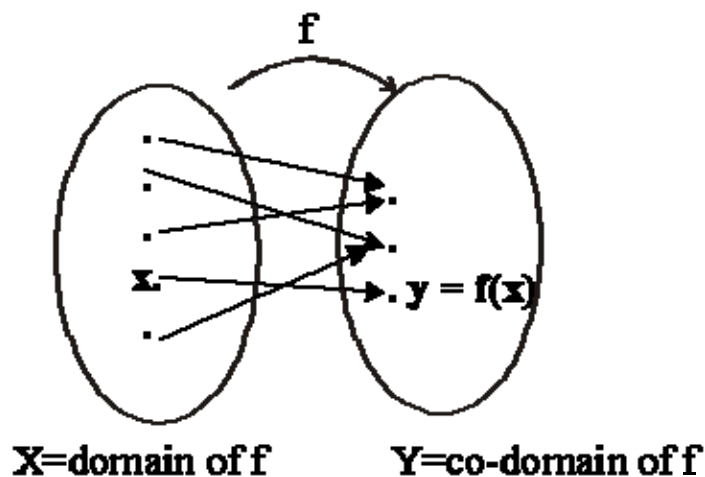

Each element y in Y equals $f(x)$ for at least one x in X

FUNCTION NOT ONTO:

A function $f: X \rightarrow Y$ is not onto iff there exists $y \in Y$ such that $\forall x \in X, f(x) \neq y$.
That is, there is some element in Y that is not the image of any element in X .

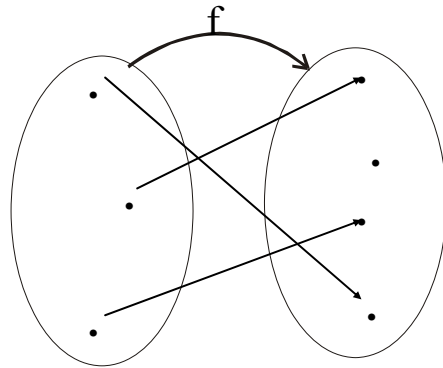

$X = \text{domain of } f$ $Y = \text{co-domain of } f$

EXAMPLE:

Which of the arrow diagrams define onto functions?

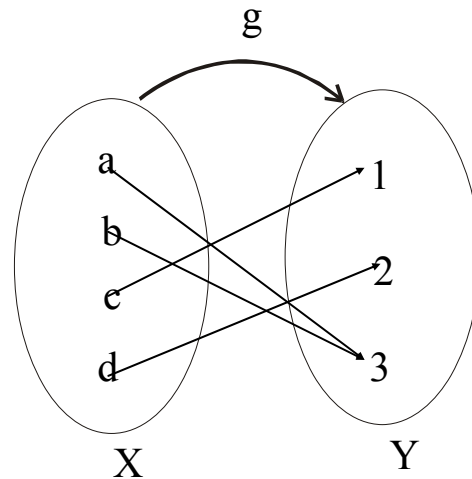
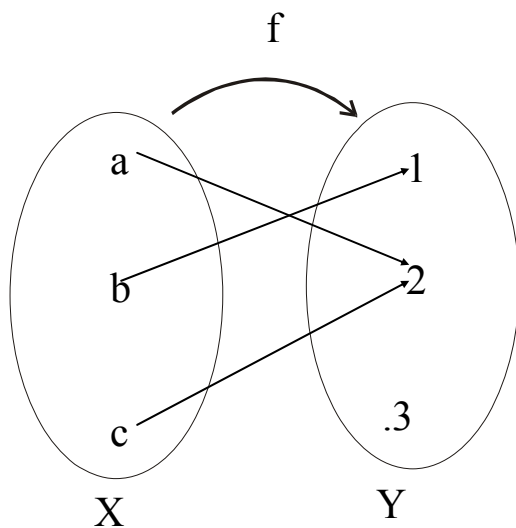

SOLUTION:

f is not onto because $3 \neq f(x)$ for any x in X .
element of Y equals $g(x)$ for some x in X .

as $1 = g(c); 2 = g(d); 3 = g(a) = g(b)$

g is clearly onto because each

EXAMPLE:

Define $f: \mathbb{R} \rightarrow \mathbb{R}$ by the rule

$$f(x) = 4x - 1 \quad \text{for all } x \in \mathbb{R}$$

Is f onto? Prove or give a counter example.

SOLUTION:

Let $y \in \mathbb{R}$. We search for an $x \in \mathbb{R}$ such that

$$\begin{aligned} f(x) &= y \\ \text{or } 4x-1 &= y && \text{(by definition of } f) \end{aligned}$$

Solving it for x , we find $x = \frac{y+1}{4} \in \mathbb{R}$. Hence for every $y \in \mathbb{R}$, there

exists $x = \frac{y+1}{4} \in \mathbb{R}$ such that

$$\begin{aligned} f(x) &= f\left(\frac{y+1}{4}\right) \\ &= 4 \cdot \left(\frac{y+1}{4}\right) - 1 = (y+1) - 1 = y \end{aligned}$$

Hence f is onto.

EXAMPLE:

Define $h: \mathbb{Z} \rightarrow \mathbb{Z}$ by the rule

$$h(n) = 4n - 1 \text{ for all } n \in \mathbb{Z}$$

Is h onto? Prove or give a counter example.

SOLUTION:

Let $m \in \mathbb{Z}$. We search for an $n \in \mathbb{Z}$ such that $h(n) = m$.

$$\text{or } 4n - 1 = m \quad \text{(by definition of } h)$$

Solving it for n , we find $n = \frac{m+1}{4}$

But $n = \frac{m+1}{4}$ is not always an integer for all $m \in \mathbb{Z}$.

As a **counter example**, let $m = 0 \in \mathbb{Z}$, then

$$\begin{aligned} h(n) &= 0 \\ \Rightarrow 4n-1 &= 0 \\ \Rightarrow 4n &= 1 \end{aligned}$$

$$\Rightarrow n = \frac{1}{4} \notin \mathbb{Z}$$

Hence there is no integer n for which $h(n) = 0$.

Accordingly, h is not onto.

GRAPH OF ONTO FUNCTION:

A graph of a function f is onto iff every horizontal line intersects the graph in at least one point.

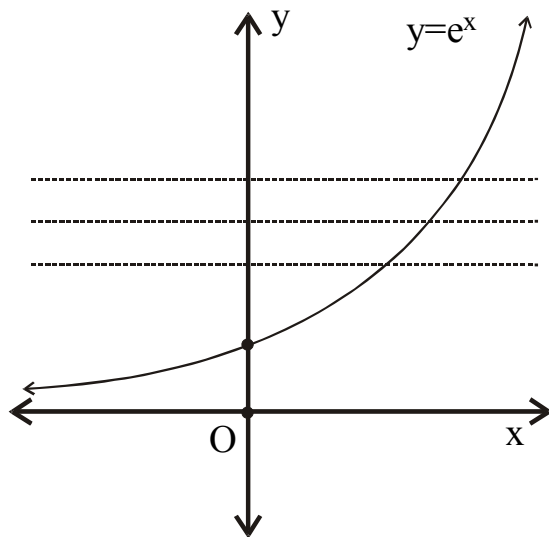
EXAMPLE:

ONTO FUNCTION
from \mathbb{R} to \mathbb{R}^+

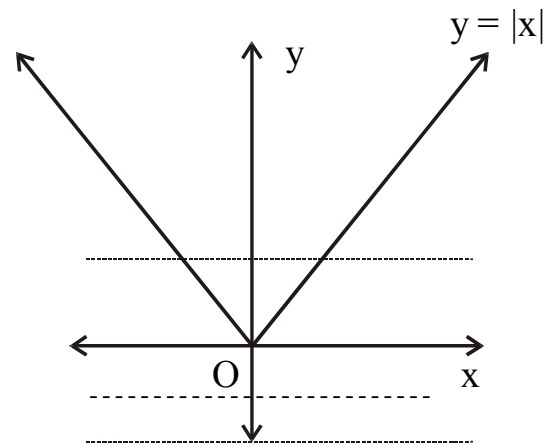

NOT ONTO FUNCTION FROM
 \mathbb{R} to \mathbb{R}

EXERCISE:

Let $X = \{1, 5, 9\}$ and $Y = \{3, 4, 7\}$. Define $g: X \rightarrow Y$ by specifying that

$$g(1) = 7, \quad g(5) = 3, \quad g(9) = 4$$

Is g one-to-one? Is g onto?

SOLUTION:

g is one-to-one because each of the three elements of X are mapped to a different elements of Y by g .

$$g(1) \neq g(5), \quad g(1) \neq g(9), \quad g(5) \neq g(9)$$

g is onto as well, because each of the three elements of co-domain Y of g is the image of some element of the domain of g .

$$3 = g(5), \quad 4 = g(9), \quad 7 = g(1)$$

EXERCISE:

Define $f: P(\{a,b,c\}) \rightarrow Z$ as follows:

for all $A \in P(\{a,b,c\})$, $f(A) =$ the number of elements in A .

- Is f one-to-one? Justify.
- Is f onto? Justify.

SOLUTION:

- f is not one-to-one because $f(\{a\}) = 1$ and $f(\{b\}) = 1$ but $\{a\} \neq \{b\}$
- f is not onto because, there is no element of $P(\{a,b,c\})$ that is mapped to $4 \in Z$.

EXERCISE:

Determine if each of the functions is injective or surjective.

- $f: Z \rightarrow Z^+$ define as $f(x) = |x|$
- $g: Z^+ \rightarrow Z^+ \times Z^+$ defined as $g(x) = (x, x+1)$

SOLUTION:

- f is not injective**, because

$$f(1) = |1| = 1 \quad \text{and} \quad f(-1) = |-1| = 1$$

i.e., $f(1) = f(-1)$ but $1 \neq -1$

f is onto, because for every $a \in Z^+$, there exist $-a$ and $+a$ in Z such that $f(-a) = |-a| = a$ and $f(a) = |a| = a$

- $g: Z^+ \rightarrow Z^+ \times Z^+$ defined as $g(x) = (x, x+1)$

Let $g(x_1) = g(x_2)$ for $x_1, x_2 \in Z^+$

$$\Rightarrow (x_1, x_1 + 1) = (x_2, x_2 + 1) \quad (\text{by definition of } g)$$

$$\Rightarrow x_1 = x_2 \quad \text{and} \quad x_1 + 1 = x_2 + 1$$

(by equality of ordered pairs)

$$\Rightarrow x_1 = x_2$$

Thus if $g(x_1) = g(x_2)$ then $x_1 = x_2$

Hence **g is one-to-one**.

g is not onto because $(1, 1) \in Z^+ \times Z^+$ is not the image of any element of Z^+ .

BIJECTIVE FUNCTION

or

ONE-TO-ONE CORRESPONDENCE

A function $f: X \rightarrow Y$ that is both one-to-one (injective) and onto (surjective) is called a bijective function or a one-to-one correspondence.

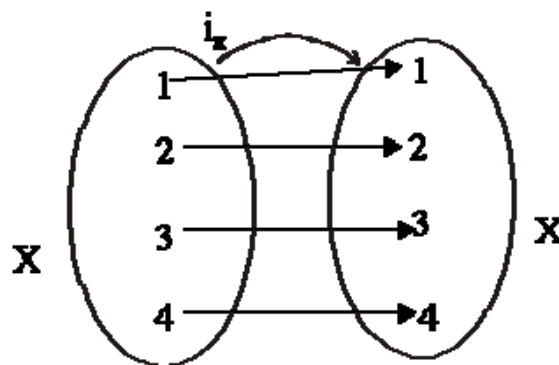

EXAMPLE:

The function $f: X \rightarrow Y$ defined by the arrow diagram is both one-to-one and onto; hence a bijective function.

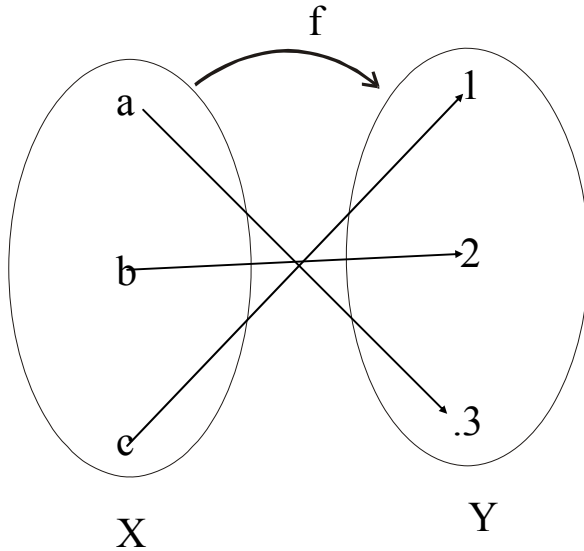
**EXERCISE:**

Let $f: \mathbb{R} \rightarrow \mathbb{R}$ be defined by the rule $f(x) = x^3$. Show that f is a bijective.

SOLUTION: **f is one-to-one**

Let $f(x_1) = f(x_2)$ for $x_1, x_2 \in \mathbb{R}$

$$\Rightarrow x_1^3 = x_2^3$$

$$\Rightarrow x_1^3 - x_2^3 = 0$$

$$\Rightarrow (x_1 - x_2)(x_1^2 + x_1x_2 + x_2^2) = 0$$

$$\Rightarrow x_1 - x_2 = 0 \quad \text{or} \quad x_1^2 + x_1x_2 + x_2^2 = 0$$

$$\Rightarrow x_1 = x_2 \quad (\text{the second equation gives no real solution})$$

Accordingly f is one-to-one.

 f is onto

Let $y \in \mathbb{R}$. We search for a $x \in \mathbb{R}$ such that

$$f(x) = y$$

$$\Rightarrow x^3 = y \quad (\text{by definition of } f)$$

$$\text{or } x = (y)^{1/3}$$

Hence for $y \in \mathbb{R}$, there exists $x = (y)^{1/3} \in \mathbb{R}$ such that

$$\begin{aligned} f(x) &= f((y)^{1/3}) \\ &= ((y)^{1/3})^3 = y \end{aligned}$$

Accordingly f is onto.

Thus, f is a bijective.

GRAPH OF BIJECTIVE FUNCTION:

A graph of a function f is bijective iff every horizontal line intersects the graph at exactly one point.

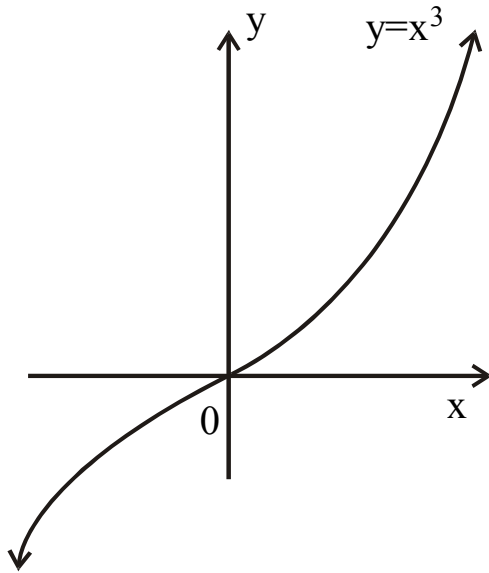

BIJECTIVE FUNCTION
from \mathbb{R} to \mathbb{R}

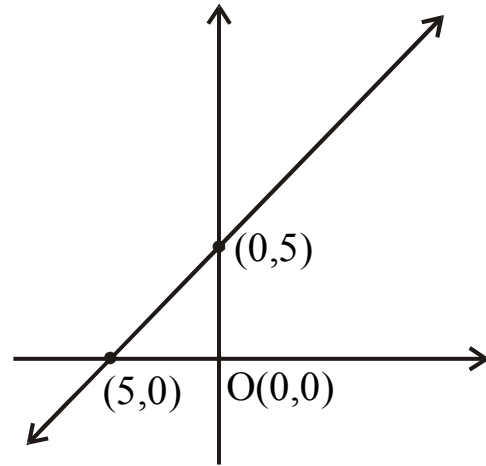

BIJECTIVE FUNCTION
from \mathbb{R} to \mathbb{R}

IDENTITY FUNCTION ON A SET:

Given a set X , define a function i_X from X to X by $i_X(x) = x$ from all $x \in X$.

The function i_X is called the identity function on X because it sends each element of X to itself.

EXAMPLE:

Let $X = \{1,2,3,4\}$. The identity function i_X on X is represented by the arrow diagram

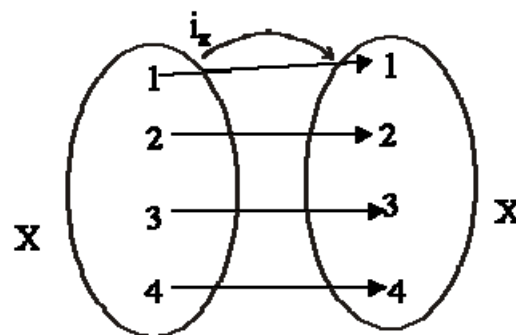

EXERCISE:

Let X be a non-empty set. Prove that the identity function on X is bijective.

SOLUTION:

Let $i_X: X \rightarrow X$ be the identity function defined as $i_X(x) = x \forall x \in X$

1. i_X is injective (one-to-one)

Let $i_X(x_1) = i_X(x_2)$ for $x_1, x_2 \in X$

$\Rightarrow x_1 = x_2$ (by definition of i_X)

Hence i_X is one-to-one.

2. i_X is surjective (onto)

Let $y \in X$ (co-domain of i_X) Then there exists $y \in X$ (domain of i_X) such that $i_X(y) = y$ Hence i_X is onto. Thus, i_X being injective and surjective is bijective.

CONSTANT FUNCTION:

A function $f: X \rightarrow Y$ is a constant function if it maps (sends) all elements of X to one element of Y i.e. $\forall x \in X, f(x) = c$, for some $c \in Y$

EXAMPLE:

The function f defined by the arrow diagram is constant.

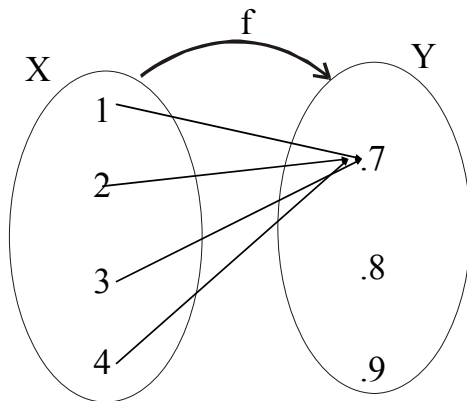
**REMARK:**

1. A constant function is one-to-one iff its domain is a singleton.
2. A constant function is onto iff its co-domain is a singleton.

Lecture No.17 Inverse function

EQUALITY OF FUNCTIONS:

Suppose f and g are functions from X to Y . Then f equals g , written $f = g$, if, and only if, $f(x) = g(x)$ for all $x \in X$

EXAMPLE:

Define $f: \mathbb{R} \rightarrow \mathbb{R}$ and $g: \mathbb{R} \rightarrow \mathbb{R}$ by formulas:

$$f(x) = |x| \quad \text{for all } x \in \mathbb{R}$$

$$g(x) = \sqrt{x^2} \quad \text{for all } x \in \mathbb{R}$$

Since the absolute value of a real number equals to square root of its square

i.e., $|x| = \sqrt{x^2}$ for all $x \in \mathbb{R}$

Therefore $f(x) = g(x)$ for all $x \in \mathbb{R}$

Hence $f = g$

EXERCISE:

Define functions f and g from \mathbb{R} to \mathbb{R} by formulas: $f(x) = 2x$ and $g(x) = \frac{2x^3 + 2x}{x^2 + 1}$ for all $x \in \mathbb{R}$. Show that $f = g$

SOLUTION:

$$\begin{aligned} g(x) &= \frac{2x^3 + 2x}{x^2 + 1} \\ &= \frac{2x(x^2 + 1)}{(x^2 + 1)} \\ &= 2x \quad [\because x^2 + 1 \neq 0] \\ &= f(x) \quad \text{for all } x \in \mathbb{R} \end{aligned}$$

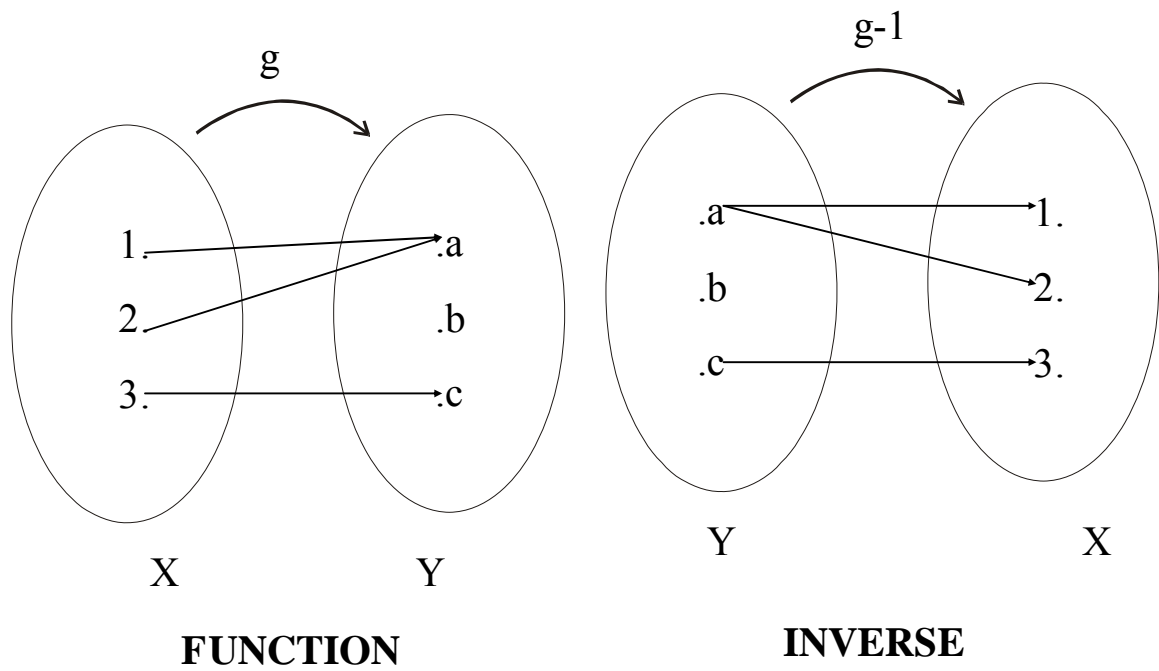
INVERSE OF A FUNCTION

Remark: *Inverse of a function may not be a function.*

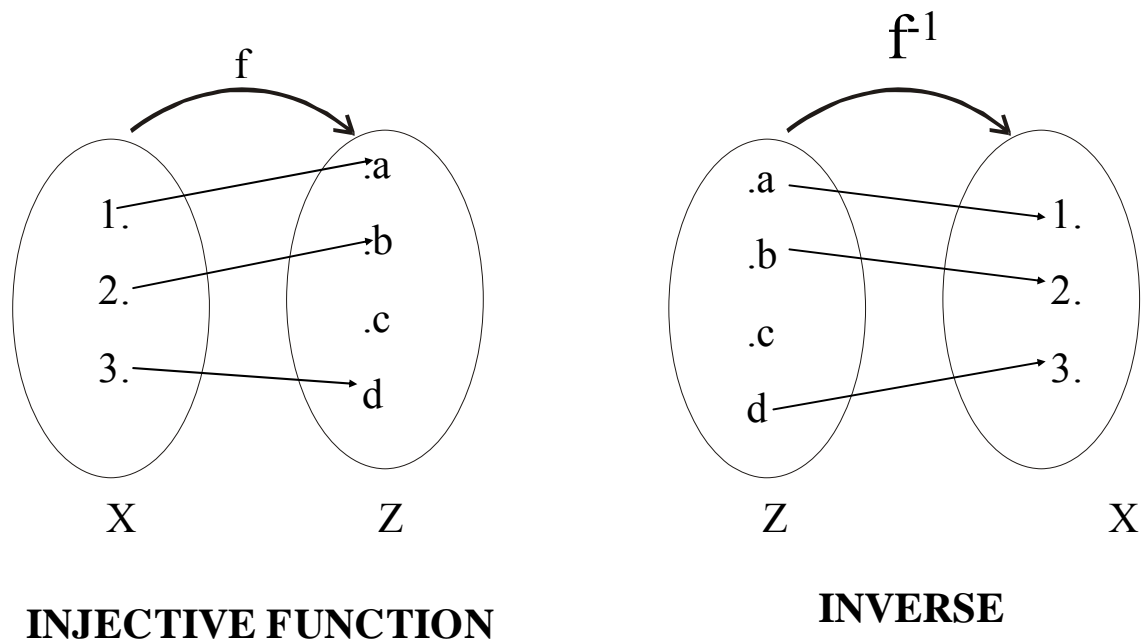

Note: *Inverse of an injective function may not be a function.*

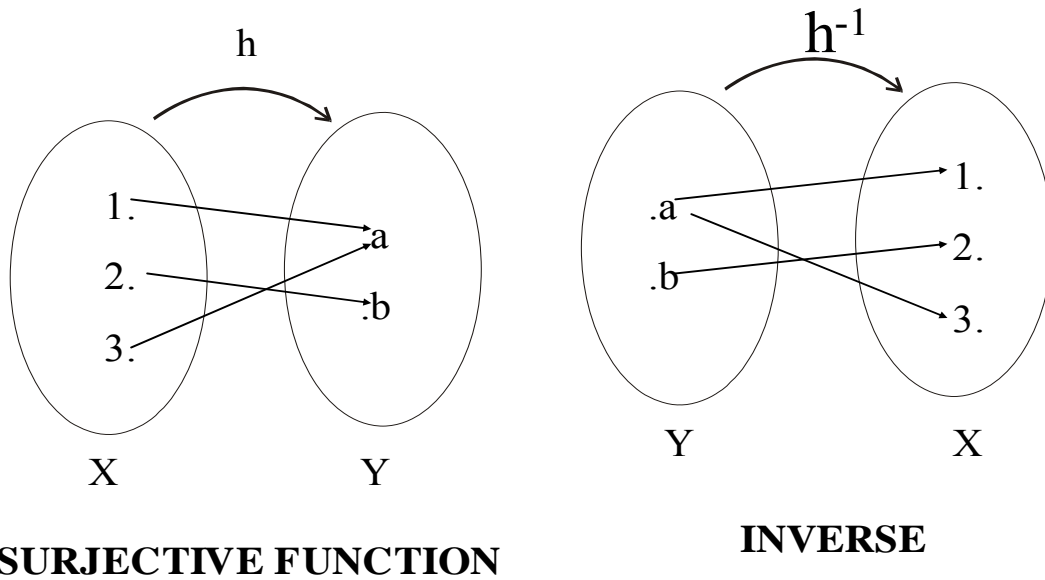

Note: Inverse of a surjective function may not be a function.

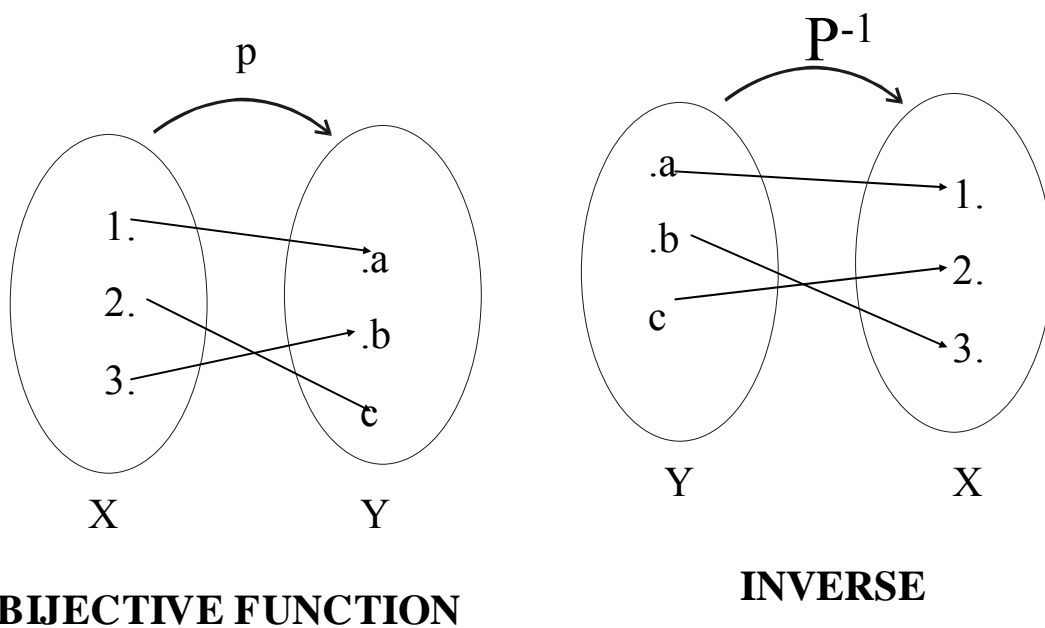

Note: Inverse of a surjective function may not be a function.

INVERSE FUNCTION:

Suppose $f: X \rightarrow Y$ is a bijective function. Then the inverse function $f^{-1}: Y \rightarrow X$ is defined as:

$$\forall y \in Y, f^{-1}(y) = x \Leftrightarrow y = f(x)$$

That is, f^{-1} sends each element of Y back to the element of X that it came from under f .

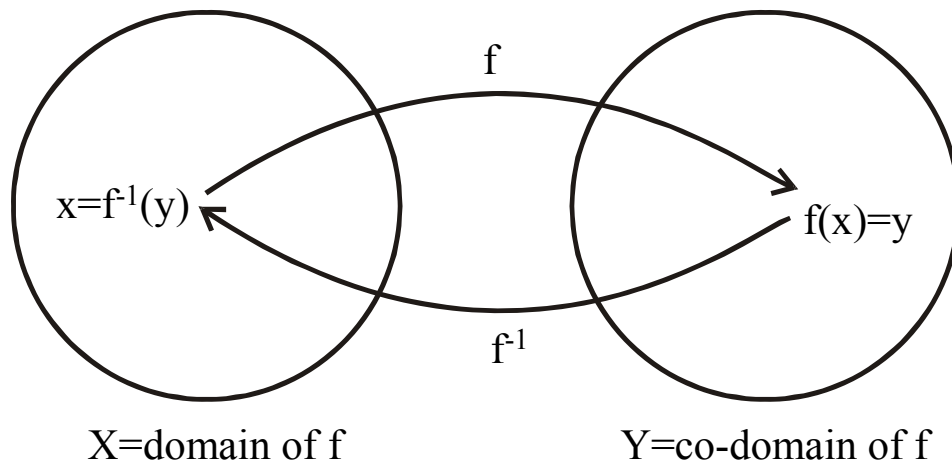
**REMARK:**

A function whose inverse function exists is called an invertible function.

INVERSE FUNCTION FROM AN ARROW DIAGRAM:

Let the bijection $f: X \rightarrow Y$ be defined by the arrow diagram.

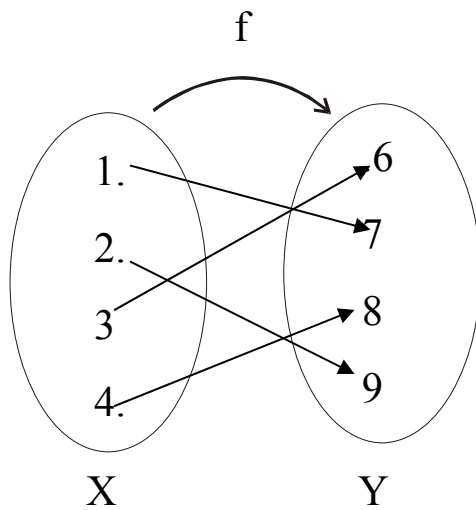

The inverse function $f^{-1}: Y \rightarrow X$ is represented below by the arrow diagram.

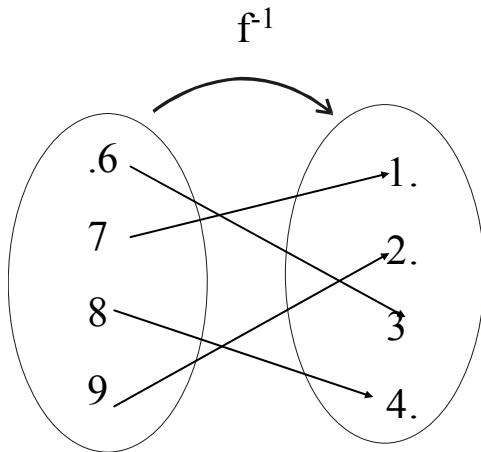

INVERSE FUNCTION FROM A FORMULA:

Let $f: \mathbb{R} \rightarrow \mathbb{R}$ be defined by the formula $f(x) = 4x - 1 \quad \forall x \in \mathbb{R}$.
Then f is bijective, therefore f^{-1} exists. By definition of f^{-1} ,

$$f^{-1}(y) = x \Leftrightarrow f(x) = y$$

Now solving $f(x) = y$ for x

$$\Leftrightarrow 4x - 1 = y \quad (\text{by definition of } f)$$

$$\Leftrightarrow 4x = y + 1$$

$$\Leftrightarrow x = \frac{y+1}{4}$$

Hence, $f^{-1}(y) = \frac{y+1}{4}$ is the inverse of $f(x) = 4x - 1$ which defines $f^{-1}: \mathbb{R} \rightarrow \mathbb{R}$.

WORKING RULE TO FIND INVERSE FUNCTION:

Let $f: X \rightarrow Y$ be a one-to-one correspondence defined by the formula $f(x) = y$.

1. Solve the equation $f(x) = y$ for x in terms of y .
2. $f^{-1}(y)$ equals the right hand side of the equation found in step 1.

EXAMPLE:

Let a function f be defined on a set of real numbers as

$$f(x) = \frac{x+1}{x-1} \quad \text{for all real numbers } x \neq 1.$$

1. Show that f is a bijective function on $\mathbb{R} - \{1\}$.
2. Find the inverse function f^{-1} .

SOLUTION:

1. To show: **f is injective**

Let $x_1, x_2 \in \mathbb{R} - \{1\}$ and suppose
 $f(x_1) = f(x_2)$ we have to show that $x_1 = x_2$

$$\Rightarrow \frac{x_1 + 1}{x_1 - 1} = \frac{x_2 + 1}{x_2 - 1} \quad (\text{by definition of } f)$$

$$\Rightarrow (x_1 + 1)(x_2 - 1) = (x_2 + 1)(x_1 - 1)$$

$$\Rightarrow x_1 x_2 - x_1 + x_2 - 1 = x_1 x_2 - x_2 + x_1 - 1$$

$$\Rightarrow -x_1 + x_2 = -x_2 + x_1$$

$$\Rightarrow x_2 + x_2 = x_1 + x_1$$

$$\Rightarrow 2x_2 = 2x_1$$

$$\Rightarrow x_2 = x_1$$

Hence f is injective.

b. Next to show: f is surjective

Let $y \in \mathbb{R} - \{1\}$. We look for an $x \in \mathbb{R} - \{1\}$ such that $f(x) = y$

$$\Rightarrow x + 1 = y(x-1)$$

$$\Rightarrow x + 1 = yx - y$$

$$\Rightarrow 1 + y = xy - x$$

$$\Rightarrow 1 + y = x(y-1)$$

$$\Rightarrow x = \frac{y+1}{y-1}$$

Thus for each $y \in \mathbb{R} - \{1\}$, there exists $x = \frac{y+1}{y-1} \in \mathbb{R} - \{1\}$

such that $f(x) = f\left(\frac{y+1}{y-1}\right) = y$

Accordingly f is surjective

2. inverse function of f

The given function f is defined by the rule

$$f(x) = \frac{x+1}{x-1} = y \quad (\text{say})$$

$$\Rightarrow x + 1 = y(x-1)$$

$$\Rightarrow x + 1 = yx - y$$

$$\Rightarrow y + 1 = yx - x$$

$$\Rightarrow y + 1 = x(y-1)$$

$$\Rightarrow x = \frac{y+1}{y-1}$$

$$\text{Hence } f^{-1}(y) = \frac{y+1}{y-1}; \quad y \neq 1$$

EXERCISE:

Let $f: \mathbb{R} \rightarrow \mathbb{R}$ be defined by

$$f(x) = x^3 + 5$$

Show that f is one-to-one and onto. Find a formula that defines the inverse function f^{-1} .

SOLUTION:

1. f is one-to-one

Let $f(x_1) = f(x_2)$ for $x_1, x_2 \in \mathbb{R}$

$$\Rightarrow x_1^3 + 5 = x_2^3 + 5 \quad (\text{by definition of } f)$$

$$\Rightarrow x_1^3 = x_2^3 \quad (\text{subtracting 5 on both sides})$$

$$\Rightarrow x_1 = x_2 \quad \text{.Hence } f \text{ is one-to-one.}$$

2. f is onto

Let $y \in \mathbb{R}$. We search for an $x \in \mathbb{R}$ such that $f(x) = y$.

$$\Rightarrow x^3 + 5 = y \quad (\text{by definition of } f)$$

$$\Rightarrow x^3 = y - 5$$

$$\Rightarrow x = \sqrt[3]{y-5}$$

Thus for each $y \in \mathbb{R}$, there exists $x = \sqrt[3]{y-5} \in \mathbb{R}$ such that

$$\begin{aligned} f(x) &= f\left(\sqrt[3]{y-5}\right) \\ &= \left(\sqrt[3]{y-5}\right)^3 + 5 \quad (\text{by definition of } f) \\ &= (y-5) + 5 = y \end{aligned}$$

Hence f is onto.

3. formula for f^{-1}

f is defined by $y = f(x) = x^3 + 5$

$$\Rightarrow y-5 = x^3$$

or $x = \sqrt[3]{y-5}$

Hence $f^{-1}(y) = \sqrt[3]{y-5}$

which defines the inverse function

COMPOSITION OF FUNCTIONS:

Let $f: X \rightarrow Y'$ and $g: Y \rightarrow Z$ be functions with the property that the range of f is a subset of the domain of g i.e. $f(X) \subseteq Y$.

Define a new function $\text{gof}: X \rightarrow Z$ as follows:

$$(\text{gof})(x) = g(f(x)) \quad \text{for all } x \in X$$

The function gof is called the composition of f and g .

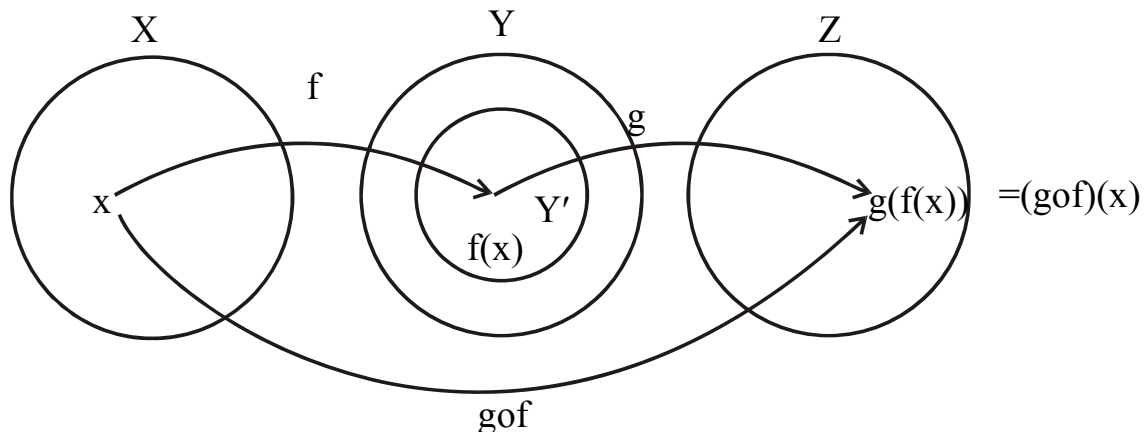
**COMPOSITION OF FUNCTIONS DEFINED BY ARROW DIAGRAMS:**

Let $X = \{1,2,3\}$, $Y' = \{a,b,c,d\}$, $Y = \{a,b,c,d,e\}$ and $Z = \{x,y,z\}$. Define functions $f: X \rightarrow Y'$ and $g: Y \rightarrow Z$ by the arrow diagrams:

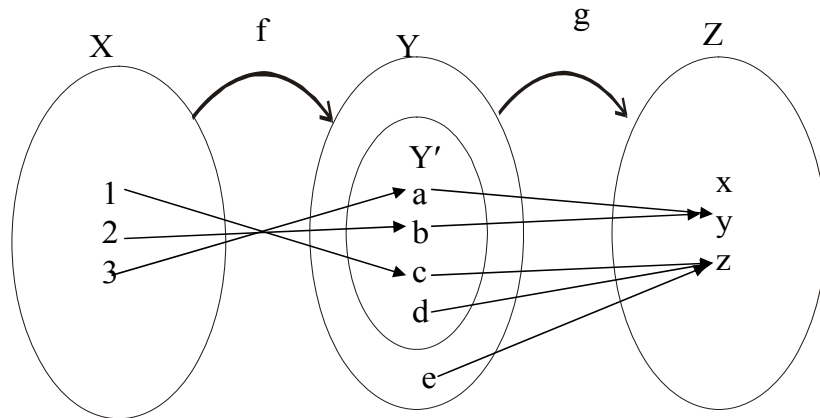

Then $g \circ f: X \rightarrow Z$ is represented by the arrow diagram.

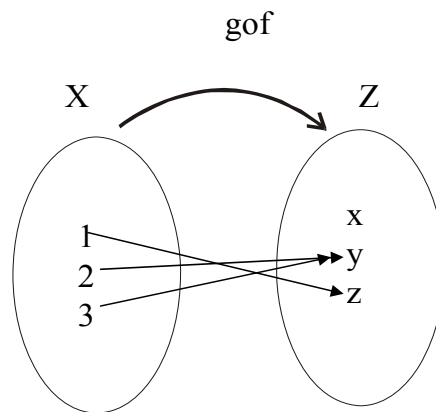

EXERCISE:

Let $A = \{1, 2, 3, 4, 5\}$ and we define functions $f: A \rightarrow A$ and then $g: A \rightarrow A$:

$$f(1)=3, f(2)=5, f(3)=3, f(4)=1, f(5)=2$$

$$g(1)=4, g(2)=1, g(3)=1, g(4)=2, g(5)=3$$

Find the composition functions $f \circ g$ and $g \circ f$.

SOLUTION:

We are the definition of the composition of functions and compute:

$$(f \circ g)(1) = f(g(1)) = f(4) = 1$$

$$(f \circ g)(2) = f(g(2)) = f(1) = 3$$

$$(f \circ g)(3) = f(g(3)) = f(1) = 3$$

$$(f \circ g)(4) = f(g(4)) = f(2) = 5$$

$$(f \circ g)(5) = f(g(5)) = f(3) = 3$$

Also

$$(g \circ f)(1) = g(f(1)) = g(3) = 1$$

$$(g \circ f)(2) = g(f(2)) = g(5) = 3$$

$$(g \circ f)(3) = g(f(3)) = g(3) = 1$$

$$(g \circ f)(4) = g(f(4)) = g(1) = 4$$

$$(g \circ f)(5) = g(f(5)) = g(2) = 1$$

REMARK: The functions $f \circ g$ and $g \circ f$ are not equal.

COMPOSITION OF FUNCTIONS DEFINED BY FORMULAS:

Let $f: Z \rightarrow Z$ and $g: Z \rightarrow Z$ be defined by

$$f(n) = n+1 \quad \text{for } n \in Z$$

and $g(n) = n^2$ for $n \in \mathbb{Z}$

- Find the compositions $g \circ f$ and $f \circ g$.
- Is $g \circ f = f \circ g$?

SOLUTION:

- By definition of the composition of functions
 $(g \circ f)(n) = g(f(n)) = g(n+1) = (n+1)^2$ for all $n \in \mathbb{Z}$ and
 $(f \circ g)(n) = f(g(n)) = f(n^2) = n^2 + 1$ for all $n \in \mathbb{Z}$
- Two functions from one set to another are equal if, and only if, they take the same values.
 In this case,

$$(g \circ f)(1) = g(f(1)) = (1 + 1)^2 = 4 \text{ where as}$$

$$(f \circ g)(1) = f(g(1)) = 1^2 + 1 = 2$$

Thus $f \circ g \neq g \circ f$

REMARK: The composition of functions is not a commutative operation.

COMPOSITION WITH THE IDENTITY FUNCTION:

Let $X = \{a, b, c, d\}$ and $Y = \{u, v, w\}$ and suppose $f: X \rightarrow Y$ be defined by:

$$f(a) = u, \quad f(b) = v, \quad f(c) = v, \quad f(d) = u$$

Find $f \circ i_x$ and $i_y \circ f$, where i_x and i_y are identity functions on X and Y respectively.

SOLUTION:

The values of $f \circ i_x$ on X are obtained as:

$$(f \circ i_x)(a) = f(i_x(a)) = f(a) = u$$

$$(f \circ i_x)(b) = f(i_x(b)) = f(b) = v$$

$$(f \circ i_x)(c) = f(i_x(c)) = f(c) = v$$

$$(f \circ i_x)(d) = f(i_x(d)) = f(d) = u$$

For all elements x in X $(f \circ i_x)(x) = f(x)$ so that $f \circ i_x = f$

The values of $i_y \circ f$ on X are obtained as:

$$(i_y \circ f)(a) = i_y(f(a)) = i_y(u) = u$$

$$(i_y \circ f)(b) = i_y(f(b)) = i_y(v) = v$$

$$(i_y \circ f)(c) = i_y(f(c)) = i_y(v) = v$$

$$(i_y \circ f)(d) = i_y(f(d)) = i_y(u) = u$$

For all elements x in X $(i_y \circ f)(x) = f(x)$ so that $i_y \circ f = f$

COMPOSING A FUNCTION WITH ITS INVERSE:

Let $X = \{a, b, c\}$ and $Y = \{x, y, z\}$. Define $f: X \rightarrow Y$ by the arrow diagram.

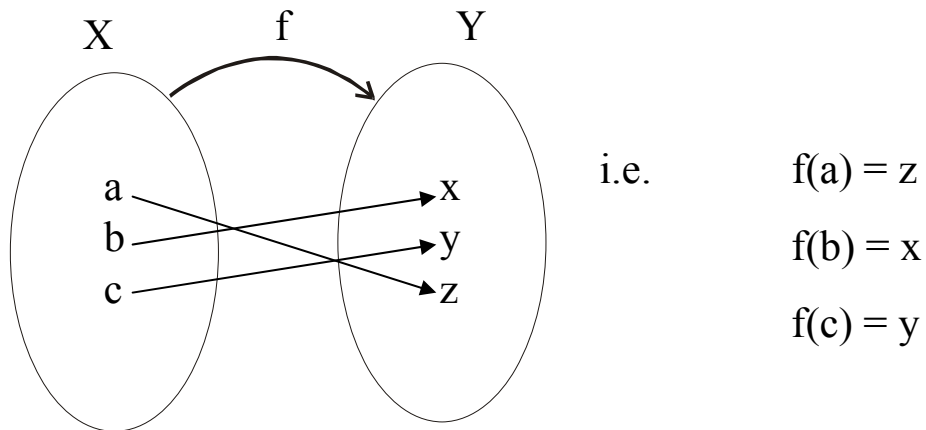

Then f is one-to-one and onto. So f^{-1} exists and is represented by the arrow diagram Below.

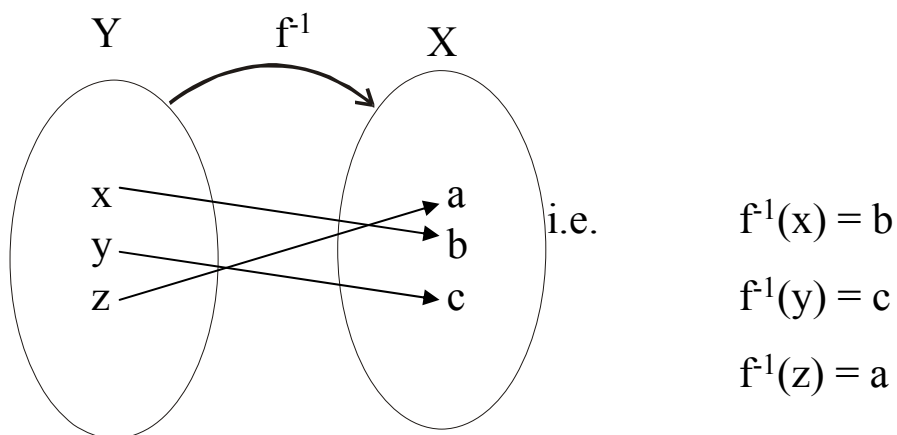

f^{-1} of is found by following the arrows from X to Y by f and back to X by f^{-1} .

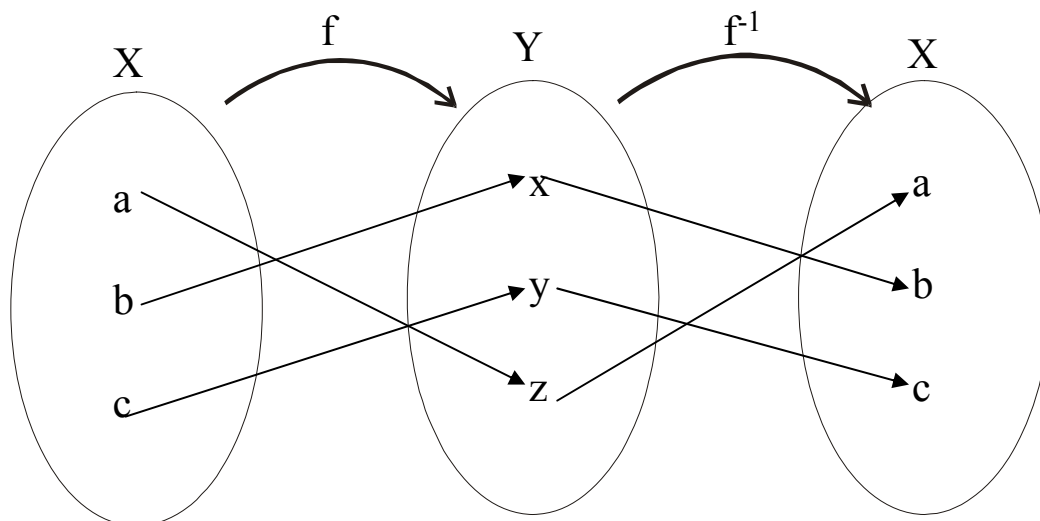

Thus, it is quite clear that

$$(f^{-1} \circ f)(a) = f^{-1}(f(a)) = f^{-1}(z) = a$$

$$(f^{-1} \circ f)(b) = f^{-1}(f(b)) = f^{-1}(x) = b \text{ and } (f^{-1} \circ f)(c) = f^{-1}(f(c)) = f^{-1}(y) = c$$

REMARK 1:

$f^{-1} \circ f : X \rightarrow X$ sends each element of X to itself. So by definition of identity function on X .

$$f^{-1} \circ f = i_x$$

Similarly, the composition of f and f^{-1} sends each element of Y to itself. Accordingly

$$f \circ f^{-1} = i_y$$

REMARK 2:

The function $f: X \rightarrow Y$ and $g: Y \rightarrow X$ are inverses of each other iff

$$g \circ f = i_x \text{ and } f \circ g = i_y$$

EXERCISE:

Let $f: \mathbb{R} \rightarrow \mathbb{R}$ and $g: \mathbb{R} \rightarrow \mathbb{R}$ be defined by

$$f(x) = 3x + 2 \quad \text{for all } x \in \mathbb{R}$$

$$\text{and } g(x) = \frac{x-2}{3} \quad \text{for all } x \in \mathbb{R}$$

Show that f and g are inverse of each other.

SOLUTION:

f and g are inverse of each other iff their composition gives the identity function. Now for all $x \in \mathbb{R}$

$$\begin{aligned} (g \circ f)(x) &= g(f(x)) \\ &= g(3x+2) \quad (\text{by definition of } f) \\ &= \frac{(3x+2)-2}{3} \quad (\text{by definition of } g) \\ &= \frac{3x}{3} = x \end{aligned}$$

$$\begin{aligned} (f \circ g)(x) &= f(g(x)) \\ &= f\left(\frac{x-2}{3}\right) \quad (\text{by definition of } g) \\ &= \frac{3\left(\frac{x-2}{3}\right)+2}{3} \quad (\text{by definition of } f) \\ &= (x-2)+2 \\ &= x \end{aligned}$$

Thus $(g \circ f)(x) = x = (f \circ g)(x)$

Hence $g \circ f$ and $f \circ g$ are identity functions. Accordingly f and g are inverse of each other.

Lecture No.18 Composition of functions

THEOREM:

If f and g are two one-to-one functions, then their composition that is $g \circ f$ is one-to-one.

PROOF:

We are taking functions $f: X \rightarrow Y$ and $g: Y \rightarrow Z$ are both one-to-one functions.

Suppose $x_1, x_2 \in X$ such that $(g \circ f)(x_1) = (g \circ f)(x_2)$

$$\Rightarrow g(f(x_1)) = g(f(x_2)) \quad (\text{definition of composition})$$

Since g is one-to-one, therefore

$$f(x_1) = f(x_2)$$

And since f is one-to-one, therefore

$$x_1 = x_2$$

Thus, we have shown that if

$$(g \circ f)(x_1) = (g \circ f)(x_2) \text{ then } x_1 = x_2$$

Hence, $g \circ f$ is one-to-one.

THEOREM:

If $f: X \rightarrow Y$ and $g: Y \rightarrow Z$ are both onto functions, then $g \circ f: X \rightarrow Z$ is onto.

PROOF:

Suppose $f: X \rightarrow Y$ and $g: Y \rightarrow Z$ are both onto functions. We must show that $g \circ f: X \rightarrow Z$ is onto.

Let $z \in Z$. Since $g: Y \rightarrow Z$ is onto, so for $z \in Z$, there exists $y \in Y$ such that $g(y) = z$. Further, since $f: X \rightarrow Y$ is onto, so for $y \in Y$, there exists $x \in X$ such that $f(x) = y$.

Hence, there exists an element x in X such that $(g \circ f)(x) = g(f(x)) = g(y) = z$

Thus, $g \circ f: X \rightarrow Z$ is onto.

THEOREM:

If $f: W \rightarrow X$, $g: X \rightarrow Y$, and $h: Y \rightarrow Z$ are functions, then

$$(h \circ g) \circ f = h \circ (g \circ f)$$

PROOF:

The two functions are equal if they assign the same image to each element in the domain, that is,

$$((h \circ g) \circ f)(x) = (h \circ (g \circ f))(x) \quad \text{for every } x \in W$$

Computing

$$((h \circ g) \circ f)(x) = (h \circ g)(f(x)) = h(g(f(x)))$$

and

$$(h \circ (g \circ f))(x) = h((g \circ f)(x)) = h(g(f(x)))$$

Hence

$$(h \circ g) \circ f = h \circ (g \circ f)$$

REMARK: The composition of functions is associative.

EXERCISE:

Suppose $f: X \rightarrow Y$ and $g: Y \rightarrow Z$ and both of these are one-to-one and onto.

Prove that $(g \circ f)^{-1}$ exists and that

$$(g \circ f)^{-1} = f^{-1} \circ g^{-1}$$

SOLUTION:

Suppose $f: X \rightarrow Y$ and $g: Y \rightarrow Z$ are bijective functions, then their composition $g \circ f: X \rightarrow Z$ is also bijective. Hence $(g \circ f)^{-1}: Z \rightarrow X$ exists.

Next, to establish $(gof)^{-1} = f^{-1}og^{-1}$, we show that
 $(f^{-1}og^{-1})o(gof) = i_x$ and $(gof)o(f^{-1}og^{-1}) = i_z$

Now consider

$$\begin{aligned}(f^{-1}og^{-1})o(gof) &= f^{-1}o(g^{-1}o(gof)) && \text{(associative law for } o\text{)} \\ &= f^{-1}o((g^{-1}og)of) && \text{(associative law for } o\text{)} \\ &= f^{-1}o(i_yof) && (g^{-1}og = i_y) \\ &= f^{-1}of && (i_yof = f) \\ &= i_x && (f: X \rightarrow Y)\end{aligned}$$

Also

$$\begin{aligned}(gof)o(f^{-1}og^{-1}) &= go(fo(f^{-1}og^{-1})) && \text{(associative law for } o\text{)} \\ &= go((fof^{-1})og^{-1}) && \text{(associative law for } o\text{)} \\ &= go(i_yog^{-1}) && (fof^{-1} = i_y) \\ &= gog^{-1} && (i_yog^{-1} = g^{-1}) \\ &= i_z && (g: Y \rightarrow Z)\end{aligned}$$

Hence $f^{-1}og^{-1} = (gof)^{-1}$

REAL-VALUED FUNCTIONS:

Let X be any set and R be the set of real numbers. A function $f: X \rightarrow R$ that assigns to each $x \in X$ a real number $f(x) \in R$ is called a real-valued function.

If $f: R \rightarrow R$, then f is called a real-valued function of a real variable.

EXAMPLE:

1. $f: R^+ \rightarrow R$ defined by $f(x) = \log x$ is a real valued function.
2. $g: R \rightarrow R$ defined by $g(x) = e^x$ is a real valued function of a real variable.

OPERATIONS ON FUNCTIONS:

SUM OF FUNCTIONS:

Let f and g be real valued functions with the same domain X . That is $f: X \rightarrow R$ and

$g: X \rightarrow R$.

The sum of f and g denoted $f+g$ is a real valued function with the same domain X

i.e. $f+g: X \rightarrow R$ defined by

$$(f+g)(x) = f(x) + g(x) \quad \forall x \in X$$

EXAMPLE:

Let $f(x) = x^2 + 1$ and $g(x) = x + 2$ defines functions f and g from R to R .

Then

$$\begin{aligned}(f+g)(x) &= f(x) + g(x) \\ &= (x^2 + 1) + (x + 2) \\ &= x^2 + x + 3 \quad \forall x \in R\end{aligned}$$

which defines the sum functions $f+g: X \rightarrow R$

DIFFERENCE OF FUNCTIONS:

Let $f: X \rightarrow R$ and $g: X \rightarrow R$ be real valued functions. The difference of f and g denoted by $f-g$ which is a function from X to R defined by

$$(f-g)(x) = f(x) - g(x) \quad \forall x \in X$$

EXAMPLE:

Let $f(x) = x^2 + 1$ and $g(x) = x + 2$ define functions f and g from R to R .

Then

$$\begin{aligned}(f-g)(x) &= f(x) - g(x) \\ &= (x^2 + 1) - (x + 2) \\ &= x^2 - x - 1 \quad \forall x \in R\end{aligned}$$

which defines the difference function $f-g: X \rightarrow R$

PRODUCT OF FUNCTIONS:

Let $f: X \rightarrow \mathbb{R}$ and $g: X \rightarrow \mathbb{R}$ be real valued functions. The product of f and g denoted $f \cdot g$ or simply fg is a function from X to \mathbb{R} defined by

$$(f \cdot g)(x) = f(x) \cdot g(x) \quad \forall x \in X$$

EXAMPLE:

Let $f(x) = x^2 + 1$ and $g(x) = x + 2$

define functions f and g from \mathbb{R} to \mathbb{R} .

$$\begin{aligned} \text{Then } (f \cdot g)(x) &= f(x) \cdot g(x) \\ &= (x^2 + 1) \cdot (x + 2) \\ &= x^3 + 2x^2 + x + 2 \quad \forall x \in \mathbb{R} \end{aligned}$$

which defines the product function $f \cdot g: X \rightarrow \mathbb{R}$

QUOTIENT OF FUNCTIONS:

Let $f: X \rightarrow \mathbb{R}$ and $g: X \rightarrow \mathbb{R}$ be real valued functions. The quotient of

f by g denoted $\frac{f}{g}$ is a function from X to \mathbb{R} defined by

$$\left(\frac{f}{g}\right)(x) = \frac{f(x)}{g(x)} \quad g(x) \text{ is not equal to } 0$$

EXAMPLE:

Let $f(x) = x^2 + 1$ and $g(x) = x + 2$ defines functions f and g from \mathbb{R} to \mathbb{R} .

Then

$$\left(\frac{f}{g}\right)(x) = \frac{f(x)}{g(x)} \quad \forall x \in X \text{ \& } g(x) \neq 0$$

$$\left(\frac{f}{g}\right)(x) = \frac{f(x)}{g(x)} \quad \forall x \in X \text{ \& } g(x) \neq 0$$

which defines the quotient function $\frac{f}{g}: X \rightarrow \mathbb{R}$.

SCALAR MULTIPLICATION:

Let $f: X \rightarrow \mathbb{R}$ be a real valued function and c is a non-zero number. Then the scalar multiplication of f is a function $c \cdot f: X \rightarrow \mathbb{R}$ defined by $(c \cdot f)(x) = c \cdot f(x) \quad \forall x \in X$

EXAMPLE:

Let $f(x) = x^2 + 1$ and $g(x) = x + 2$ defines functions f and g from \mathbb{R} to \mathbb{R} .

Then

$$\begin{aligned} (3f - 2g)(x) &= (3f)(x) - (2g)(x) \\ &= 3 \cdot f(x) - 2 \cdot g(x) \\ &= 3(x^2 + 1) - 2(x + 2) \\ &= 3x^2 - 2x - 1 \quad \forall x \in X \end{aligned}$$

EXERCISE :

If $f: \mathbb{R} \rightarrow \mathbb{R}$ and $g: \mathbb{R} \rightarrow \mathbb{R}$ are both one-to-one, is $f+g$ also one-to-one?

SOLUTION:

Here $f+g$ is not one-to-one

As a counter example; define $f: \mathbb{R} \rightarrow \mathbb{R}$ and $g: \mathbb{R} \rightarrow \mathbb{R}$ by

$$f(x) = x \quad \text{and} \quad g(x) = -x \quad \forall x \in \mathbb{R}$$

Then obviously both f and g are one-to-one

Now

$$(f+g)(x) = f(x) + g(x) = x + (-x) = 0 \quad \forall x \in \mathbb{R}$$

Clearly $f+g$ is not one-to-one because

$$(f+g)(1) = 0 \quad \text{and} \quad (f+g)(2) = 0 \quad \text{but} \quad 1 \neq 2$$

EXERCISE:

If $f: \mathbb{R} \rightarrow \mathbb{R}$ and $g: \mathbb{R} \rightarrow \mathbb{R}$ are both onto, is $f+g$ also onto? Prove or give a counter example.

SOLUTION:

$f+g$ is not onto.

As a counter example, define $f: \mathbb{R} \rightarrow \mathbb{R}$ and $g: \mathbb{R} \rightarrow \mathbb{R}$ by

$$f(x) = x \quad \text{and} \quad g(x) = -x \quad \forall x \in \mathbb{R}$$

Then obviously both f and g are onto.

$$\begin{aligned} \text{Now } (f+g)(x) &= f(x) + g(x) \\ &= x + (-x) \\ &= 0 \quad \forall x \in \mathbb{R} \end{aligned}$$

Clearly $f+g$ is not onto because only $0 \in \mathbb{R}$ has its pre-image in \mathbb{R} and no non-zero element of co-domain \mathbb{R} is the image of any element of \mathbb{R} .

EXERCISE:

Let $f: \mathbb{R} \rightarrow \mathbb{R}$ be a function and $c (\neq 0) \in \mathbb{R}$.

1. If f is one-to-one, is $c \cdot f$ also one-to-one?
2. If f is onto, is $c \cdot f$ also onto?

SOLUTION:

1. Suppose $f: \mathbb{R} \rightarrow \mathbb{R}$ is one-to-one and $c (\neq 0) \in \mathbb{R}$

$$\begin{aligned} \text{Let } (c \cdot f)(x_1) &= (c \cdot f)(x_2) \quad \text{for } x_1, x_2 \in \mathbb{R} \\ \Rightarrow c \cdot f(x_1) &= c \cdot f(x_2) \quad \text{(by definition of } c \cdot f) \\ \Rightarrow f(x_1) &= f(x_2) \quad \text{(dividing by } c \neq 0) \end{aligned}$$

Since f is one-to-one, this implies

$$x_1 = x_2$$

Hence $c \cdot f: \mathbb{R} \rightarrow \mathbb{R}$ is also one-to-one.

2. Suppose $f: \mathbb{R} \rightarrow \mathbb{R}$ is onto and $(c \neq 0) \in \mathbb{R}$.

Let $y \in \mathbb{R}$. We search for an $x \in \mathbb{R}$ such that

$$\begin{aligned} (c \cdot f)(x) &= y \quad (1) \\ \Rightarrow c \cdot f(x) &= y \quad \text{(by definition of } c \cdot f) \\ \Rightarrow f(x) &= \frac{y}{c} \quad \text{(dividing by } c \neq 0) \end{aligned}$$

Since $f: \mathbb{R} \rightarrow \mathbb{R}$ is onto, so for $\frac{y}{c} \in \mathbb{R}$, there exists some $x \in \mathbb{R}$

such that the above equation is true; and this leads back to equation (1).

Accordingly $c \cdot f: \mathbb{R} \rightarrow \mathbb{R}$ is also onto.

EXERCISE:

The real-valued function $0_X: X \rightarrow \mathbb{R}$ which is defined by

$$0_X(x) = 0 \quad \text{for all } x \in X$$

is called the zero function (on X).

Prove that for any function $f: X \rightarrow \mathbb{R}$

1. $f + 0_X = f$
2. $f \cdot 0_X = 0_X$

SOLUTION:

$$\begin{aligned}
 1. \quad \text{Since } (f + 0_X)(x) &= f(x) + 0_X(x) \\
 &= f(x) + 0 \\
 &= f(x) \quad \forall x \in X
 \end{aligned}$$

$$\text{Hence } f + 0_X = f$$

$$\begin{aligned}
 2. \quad \text{Since } (f \cdot 0_X)(x) &= f(x) \cdot 0_X(x) \\
 &= f(x) \cdot 0 \\
 &= 0 \\
 &= 0_X(x) \quad \forall x \in X
 \end{aligned}$$

$$\text{Hence } f \cdot 0_X = 0_X$$

EXERCISE:

Given a set S and a subset A , the characteristics function of A , denoted χ_A , is the function defined from S to the set $\{0,1\}$ defined as

$$\chi_A(x) = \begin{cases} 1 & \text{if } x \in A \\ 0 & \text{if } x \notin A \end{cases}$$

Show that for all subsets A and B of S

1. $\chi_{A \cap B} = \chi_A \cdot \chi_B$
2. $\chi_{A \cup B} = \chi_A + \chi_B - \chi_A \cdot \chi_B$
3. $\chi_{A^c}(x) = 1 - \chi_A(x)$

SOLUTION:

$$1. \quad \text{Prove that } \chi_{A \cap B} = \chi_A \cdot \chi_B$$

Let $x \in A \cap B$; therefore $x \in A$ and $x \in B$. Then

$$\chi_{A \cap B}(x) = 1; \chi_A(x) = 1; \chi_B(x) = 1$$

$$\begin{aligned}
 \text{Hence } \chi_{A \cap B}(x) &= 1 = (1)(1) = \chi_A(x) \chi_B(x) \\
 &= (\chi_A \cdot \chi_B)(x)
 \end{aligned}$$

SOLUTION:

Next, let $y \in (A \cap B)'$

$$\Rightarrow y \in A' \cup B'$$

$$\Rightarrow y \in A' \text{ or } y \in B'$$

Now $y \in (A \cap B)'$ i.e. $y \notin (A \cap B)$

$$\Rightarrow \chi_{(A \cap B)'}(y) = 0$$

and $y \in A' \text{ or } y \in B'$

$$\Rightarrow \chi_A(y) = 0 \text{ (as } y \notin A) \text{ or } \chi_B(y) = 0 \text{ (as } y \notin B)$$

$$\begin{aligned}
 \text{Thus } \chi_{(A \cap B)'}(y) &= 0 = (0)(0) = \chi_A(y) \chi_B(y) \\
 &= (\chi_A \cdot \chi_B)(y)
 \end{aligned}$$

Hence, $\chi_{(A \cap B)'}$ and $\chi_A \cdot \chi_B$ assign the same number to each element x in S , so by definition

$$\chi_{(A \cap B)'} = \chi_A \cdot \chi_B$$

SOLUTION:

$$2. \quad \text{Prove that } \chi_{A \cup B} = \chi_A + \chi_B - \chi_A \cdot \chi_B$$

Let $x \in A \cup B$ then $x \in A$ or $x \in B$

Now $\chi_{A \cup B}(x) = 1$ and $\chi_A(x) = 1$ or $\chi_B(x) = 1$

Three cases arise depending upon which of $\chi_A(x)$ or $\chi_B(x)$ is 1.

CASE-I (if $\chi_A(x) = 1$ & $\chi_B(x) = 1$)

$$\begin{aligned} \text{Now } \chi_A(x) + \chi_B(x) - \chi_A(x) \cdot \chi_B(x) \\ &= 1 + 1 - (1)(1) \\ &= 1 = \chi_{A \cup B}(x) \end{aligned}$$

CASE-II (if $\chi_A(x) = 1$; $\chi_B(x) = 0$)

$$\begin{aligned} \text{Now } \chi_A(x) + \chi_B(x) - \chi_A(x) \cdot \chi_B(x) \\ &= 1 + 0 - (1)(0) \\ &= 1 \\ &= \chi_{A \cup B}(x) \end{aligned}$$

CASE III (if $\chi_A(x) = 0$; $\chi_B(x) = 1$)

$$\begin{aligned} \text{Now } \chi_A(x) + \chi_B(x) - \chi_A(x) \cdot \chi_B(x) \\ &= 0 + 1 - (0)(1) \\ &= 1 \\ &= \chi_{A \cup B}(x) \end{aligned}$$

Thus in all cases

$$\chi_{A \cup B}(x) = 1 = \chi_A(x) + \chi_B(x) - \chi_A(x) \cdot \chi_B(x) \quad \forall x \in A \cup B$$

Next let $y \notin A \cup B$. Then $y \in (A \cup B)'$

$$\Rightarrow y \in A' \cap B' \quad (\text{DeMorgan's Law})$$

$$\Rightarrow y \in A' \text{ and } y \in B'$$

$$\Rightarrow y \notin A \text{ and } y \notin B$$

$$\text{Thus } \chi_{A \cup B}(y) = 0; \chi_A(y) = 0; \chi_B(y) = 0$$

$$\begin{aligned} \text{Consider } \chi_A(y) + \chi_B(y) - \chi_A(y) \cdot \chi_B(y) \\ &= 0 + 0 - 0 \\ &= 0 \\ &= \chi_{A \cup B}(y) \end{aligned}$$

Hence for all elements of S

$$\chi_{A \cup B} = \chi_A + \chi_B - \chi_A \cdot \chi_B$$

3. Prove that $\chi_{\bar{A}}(x) = 1 - \chi_A(x)$

Let $x \in \bar{A}$. Then $x \notin A$ and so

$$\chi_{\bar{A}}(x) = 1 \text{ and } \chi_A(x) = 0$$

$$\therefore A^c = \bar{A}$$

$$\therefore \chi_{\bar{A}}(x) = 1 = 1 - 0 = 1 - \chi_A(x) \quad (1)$$

Also if $y \in A$, then $y \notin \bar{A}$ and so

$$\chi_A(y) = 1 \text{ and } \chi_{\bar{A}}(y) = 0$$

$$\therefore \chi_{\bar{A}}(y) = 0 = 1 - 1 = 1 - \chi_A(y) \quad (2)$$

By (1) and (2), for all elements of S

$$\chi_{A^c}(x) = 1 - \chi_A(x)$$

EXERCISE:

If F, G and H are functions from $A = \{1,2,3\}$ to A what must be true if.

1. F is reflexive?
2. G is symmetric?
3. H is transitive, onto function?

SOLUTION:

1. F is reflexive iff every element of A is related to itself i.e. $aFa \forall a \in A$. Also F is a function from A to A, so each element of A is related to a unique (one and only one) element of A. Hence, F maps each element of A to itself so that F is an identity function.

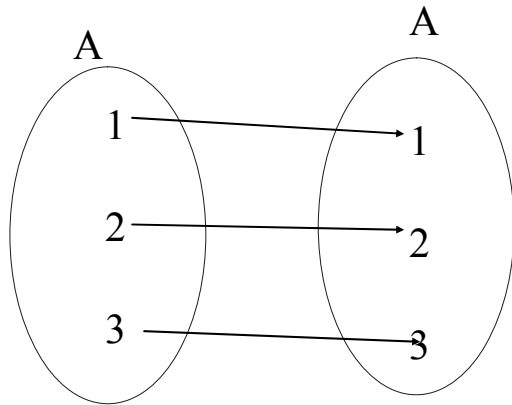

2. G is symmetric iff if aGb then $bGa \forall a, b \in A$. Now, in the present case.

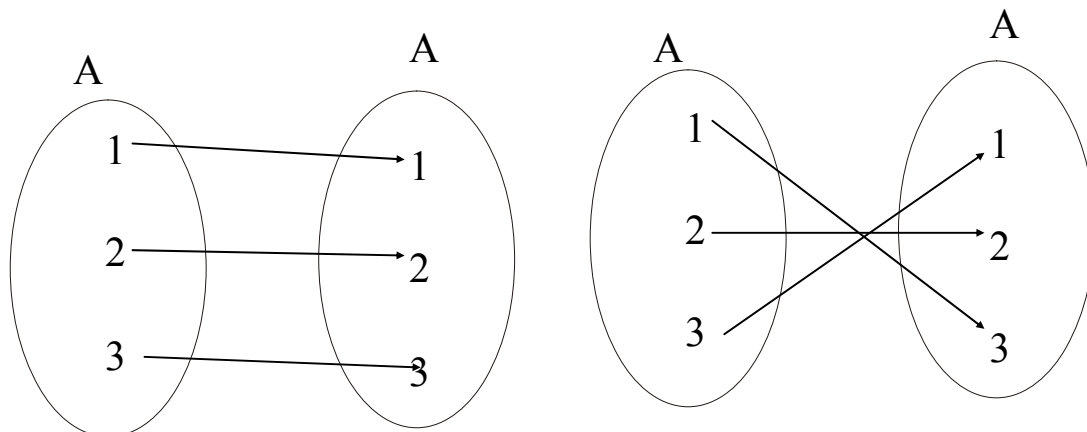

i.e. G is both one-to-one and onto (a bijective function)

3. H is transitive iff if aHb and bHc then aHc . $\forall a,b,c \in A$.
In our case

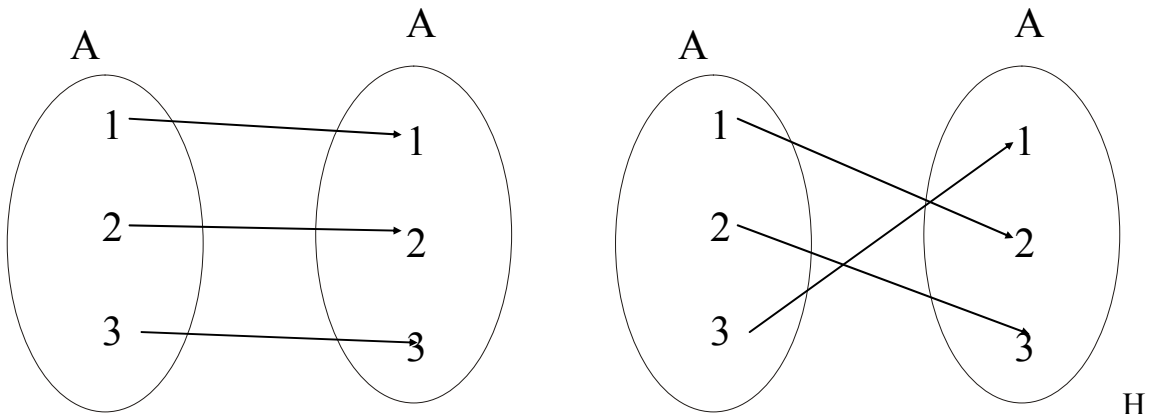

is transitive, onto function if and only if it is an identity function.

FINITE AND INFINITE SETS

FINITE SET:

A set is called finite if, and only if, it is the empty set or there is one-to-one correspondence from $\{1,2,3,\dots,n\}$ to it, where n is a positive integer.

INFINITE SET:

A non empty set that cannot be put into one-to-one correspondence with $\{1,2,3,\dots,n\}$, for any positive integer n , is called infinite set.

CARDINALITY:

Let A and B be any sets. A has the same cardinality as B if, and only if, there is a one-to-one correspondence from A to B (Cardinality means "the total number of elements in a set").

Note: One-to-One correspondence means the condition of One-One and Onto.

COUNTABLE SET:

A set is **countably infinite** if, and only if, it has the same cardinality as the set of positive integers Z^+ .

A set is called **countable** if, and only if, it is finite or countably infinite.

A set that is not countable is called **uncountable**.

EXAMPLE:

The set Z of all integers is countable.

SOLUTION:

We find a function from the set of positive integers Z^+ to Z that is one-to-one and onto.

Define $f: Z^+ \rightarrow Z$ by

$$f(n) = \begin{cases} \frac{n}{2} & \text{if } n \text{ is an even positive integer} \\ -\frac{n-1}{2} & \text{if } n \text{ is an odd positive integer} \end{cases}$$

Then f clearly maps distinct elements of Z^+ to distinct integers. Moreover, every integer m is the image of some positive integer under f . Thus f is bijective and so the set Z of all integers is countable (countably infinite).

EXERCISE:

Show that the set $2Z$ of all even integers is countable.

SOLUTION:

Consider the function h from Z to $2Z$ defined as follows

$$h(n) = 2n \text{ for all } n \in Z$$

Then clearly h is one-to-one. For if

$$h(n_1) = h(n_2) \text{ then}$$

$$2n_1 = 2n_2 \quad (\text{by definition of } h)$$

$$\Rightarrow n_1 = n_2$$

Also every even integer $2n$ is the image of integer n under h . Hence h is onto as well.

Thus $h:Z \rightarrow 2Z$ is bijective. Since Z is countable, it follows that $2Z$ is countable.

IMAGE OF A SET:

Let $f: X \rightarrow Y$ be a function and $A \subseteq X$.

The image of A under f is denoted and defined as:

$$f(A) = \{y \in Y \mid y = f(x), \text{ for some } x \text{ in } A\}$$

EXAMPLE:

Let $f: X \rightarrow Y$ be defined by the arrow diagram

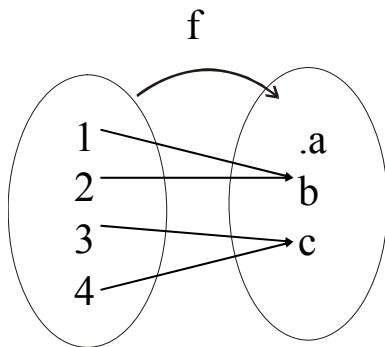

Let $A = \{1,2\}$ and $B = \{2,3\}$ then

$$f(A) = \{b\} \text{ and } f(B) = \{b,c\}$$

INVERSE IMAGE OF A SET:

Let $f: X \rightarrow Y$ be a function and $C \subseteq Y$.

The inverse image of C under f is denoted and defined as:

$$f^{-1}(C) = \{x \in X \mid f(x) \in C\}$$

EXAMPLE:

Let $f: X \rightarrow Y$ be defined by the arrow diagram.

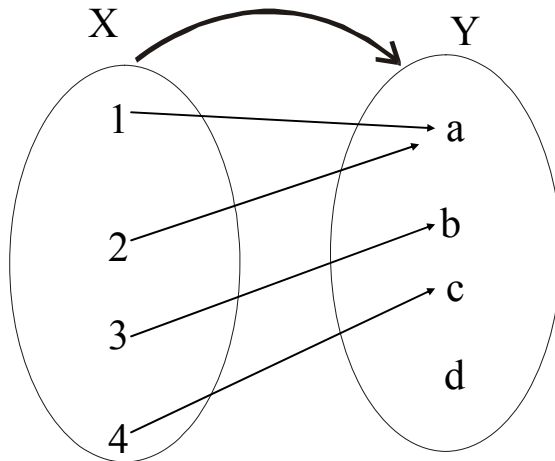

Let $C = \{a\}$, $D = \{b, c\}$, $E = \{d\}$ then $f^{-1}(C) = \{1, 2\}$,
 $f^{-1}(D) = \{3, 4\}$, and $f^{-1}(E) = \emptyset$

SOME RESULTS

Let $f: X \rightarrow Y$ is a function. Let A and B be subsets of X and C and D be subsets of Y .

1. if $A \subseteq B$ then $f(A) \subseteq f(B)$
2. $f(A \cup B) = f(A) \cup f(B)$
3. $f(A \cap B) \subseteq f(A) \cap f(B)$
4. $f(A - B) \supseteq f(A) - f(B)$
5. if $C \subseteq D$, then $f^{-1}(C) \subseteq f^{-1}(D)$
6. $f^{-1}(C \cup D) = f^{-1}(C) \cup f^{-1}(D)$
7. $f^{-1}(C \cap D) = f^{-1}(C) \cap f^{-1}(D)$
8. $f^{-1}(C - D) = f^{-1}(C) - f^{-1}(D)$

Lecture No.19 Sequence

SEQUENCE:

A sequence is just a list of elements usually written in a row.

EXAMPLES:

1. 1, 2, 3, 4, 5, ...
2. 4, 8, 12, 16, 20, ...
3. 2, 4, 8, 16, 32, ...
4. 1, 1/2, 1/3, 1/4, 1/5, ...
5. 1, 4, 9, 16, 25, ...
6. 1, -1, 1, -1, 1, -1, ...

NOTE:

The symbol “...” is called ellipsis, and reads “and so forth”

FORMAL DEFINITION:

A sequence is a function whose domain is the set of integers greater than or equal to a particular integer n_0 .

Usually this set is the set of Natural numbers $\{1, 2, 3, \dots\}$ or the set of whole numbers $\{0, 1, 2, 3, \dots\}$.

NOTATION:

We use the notation a_n to denote the image of the integer n , and call it a term of the sequence. Thus

$$a_1, a_2, a_3, a_4, \dots, a_n, \dots$$

represent the terms of a sequence defined on the set of natural numbers N .

Note that a sequence is described by listing the terms of the sequence in order of increasing subscripts.

FINDING TERMS OF A SEQUENCE GIVEN BY AN EXPLICIT FORMULA:

An explicit formula or general formula for a sequence is a rule that shows how the values of a_k depends on k .

EXAMPLE:

Define a sequence a_1, a_2, a_3, \dots by the explicit formula

$$a_k = \frac{k}{k+1} \quad \text{for all integers } k \geq 1$$

The first four terms of the sequence are:

$$a_1 = \frac{1}{1+1} = \frac{1}{2}, a_2 = \frac{2}{2+1} = \frac{2}{3}, a_3 = \frac{3}{3+1} = \frac{3}{4}$$

$$\text{and fourth term is } a_4 = \frac{4}{4+1} = \frac{4}{5}$$

EXAMPLE:

Write the first four terms of the sequence defined by the formula

$$b_j = 1 + 2^j, \text{ for all integers } j \geq 0$$

SOLUTION:

$$b_0 = 1 + 2^0 = 1 + 1 = 2$$

$$b_1 = 1 + 2^1 = 1 + 2 = 3$$

$$b_2 = 1 + 2^2 = 1 + 4 = 5$$

$$b_3 = 1 + 2^3 = 1 + 8 = 9$$

REMARK:

The formula $b_j = 1 + 2^j$, for all integers $j \geq 0$ defines an infinite sequence having infinite number of values.

EXERCISE:

Compute the first six terms of the sequence defined by the formula

$$C_n = 1 + (-1)^n \text{ for all integers } n \geq 0$$

SOLUTION:

$$C_0 = 1 + (-1)^0 = 1 + 1 = 2 \qquad C_1 = 1 + (-1)^1 = 1 + (-1) = 0$$

$$C_2 = 1 + (-1)^2 = 1 + 1 = 2 \qquad C_3 = 1 + (-1)^3 = 1 + (-1) = 0$$

$$C_4 = 1 + (-1)^4 = 1 + 1 = 2 \qquad C_5 = 1 + (-1)^5 = 1 + (-1) = 0$$

REMARK:

(1) If n is even, then $C_n = 2$ and if n is odd, then $C_n = 0$

Hence, the sequence oscillates endlessly between 2 and 0.

(2) An infinite sequence may have only a finite number of values.

EXAMPLE:

Write the first four terms of the sequence defined by

$$C_n = \frac{(-1)^n n}{n+1} \text{ for all integers } n \geq 1$$

SOLUTION:

$$C_1 = \frac{(-1)^1(1)}{1+1} = \frac{-1}{2}, C_2 = \frac{(-1)^2(2)}{2+1} = \frac{2}{3}, C_3 = \frac{(-1)^3(3)}{3+1} = \frac{-3}{4}$$

$$\text{And fourth term is } C_4 = \frac{(-1)^4(4)}{4+1} = \frac{4}{5}$$

REMARK: A sequence whose terms alternate in sign is called an alternating sequence.

EXERCISE:

Find explicit formulas for sequences with the initial terms given:

1. 0, 1, -2, 3, -4, 5, ...

SOLUTION:

$$a_n = (-1)^{n+1} n \text{ for all integers } n \geq 0$$

2. $1 - \frac{1}{2}, \frac{1}{2} - \frac{1}{3}, \frac{1}{3} - \frac{1}{4}, \frac{1}{4} - \frac{1}{5}, \dots$

SOLUTION:

$$b_k = \frac{1}{k} - \frac{1}{k+1} \text{ for all integers } n \geq 1$$

3. 2, 6, 12, 20, 30, 42, 56, ...

SOLUTION:

$$C_n = n(n+1) \text{ for all integers } n \geq 1$$

4. $1/4, 2/9, 3/16, 4/25, 5/36, 6/49, \dots$

SOLUTION:

OR $d_i = \frac{i}{(i+1)^2}$ for all integers $i \geq 1$

$$d_j = \frac{j+1}{(j+2)^2} \text{ for all integers } j \geq 0$$

ARITHMETIC SEQUENCE:

A sequence in which every term after the first is obtained from the preceding term by adding a constant number is called an arithmetic sequence or arithmetic progression (A.P.)

The constant number, being the difference of any two consecutive terms is called the common difference of A.P., commonly denoted by “d”.

EXAMPLES:

1. $5, 9, 13, 17, \dots$ (common difference = 4)
2. $0, -5, -10, -15, \dots$ (common difference = -5)
3. $x + a, x + 3a, x + 5a, \dots$ (common difference = 2a)

GENERAL TERM OF AN ARITHMETIC SEQUENCE:

Let **a** be the first term and **d** be the common difference of an arithmetic sequence. Then the sequence is $a, a+d, a+2d, a+3d, \dots$

If a_i , for $i \geq 1$, represents the terms of the sequence then

$$a_1 = \text{first term} = a = a + (1-1)d$$

$$a_2 = \text{second term} = a + d = a + (2-1)d$$

$$a_3 = \text{third term} = a + 2d = a + (3-1)d$$

By symmetry

$$a_n = \text{nth term} = a + (n-1)d \text{ for all integers } n \geq 1.$$

EXAMPLE:

Find the 20th term of the arithmetic sequence

$$3, 9, 15, 21, \dots$$

SOLUTION:

$$\text{Here } a = \text{first term} = 3$$

$$d = \text{common difference} = 9 - 3 = 6$$

$$n = \text{term number} = 20$$

$$a_{20} = \text{value of 20th term} = ?$$

$$\text{Since } a_n = a + (n-1)d; \quad n \geq 1$$

$$\begin{aligned} \therefore a_{20} &= 3 + (20-1)6 \\ &= 3 + 114 \\ &= 117 \end{aligned}$$

EXAMPLE:

Which term of the arithmetic sequence

$$4, 1, -2, \dots, \text{ is } -77$$

SOLUTION:

Here a = first term = 4

d = common difference = $1 - 4 = -3$

a_n = value of n th term = -77

n = term number = ?

Since

$$a_n = a + (n - 1)d \quad n \geq 1$$

$$\Rightarrow -77 = 4 + (n - 1)(-3)$$

$$\Rightarrow -77 - 4 = (n - 1)(-3)$$

OR

$$\frac{-81}{-3} = n - 1$$

OR

$$27 = n - 1$$

$$n = 28$$

Hence -77 is the 28th term of the given sequence.

EXERCISE:

Find the 36th term of the arithmetic sequence whose 3rd term is 7 and 8th term is 17.

SOLUTION:

Let a be the first term and d be the common difference of the arithmetic sequence.

Then

$$a_n = a + (n - 1)d \quad n \geq 1$$

$$\Rightarrow a_3 = a + (3 - 1)d$$

and $a_8 = a + (8 - 1)d$

Given that $a_3 = 7$ and $a_8 = 17$. Therefore

$$7 = a + 2d \dots \dots \dots (1)$$

and $17 = a + 7d \dots \dots \dots (2)$

Subtracting (1) from (2), we get,

$$10 = 5d$$

$$\Rightarrow d = 2$$

Substituting $d = 2$ in (1) we have

$$7 = a + 2(2)$$

which gives $a = 3$

Thus, $a_n = a + (n - 1)d$

$$a_n = 3 + (n - 1)2 \quad (\text{using values of } a \text{ and } d)$$

Hence the value of 36th term is

$$a_{36} = 3 + (36 - 1)2$$

$$= 3 + 70$$

$$= 73$$

GEOMETRIC SEQUENCE:

A sequence in which every term after the first is obtained from the preceding term by multiplying it with a constant number is called a geometric sequence or geometric progression (G.P.)

The constant number, being the ratio of any two consecutive terms is called the common ratio of the G.P. commonly denoted by “ r ”.

EXAMPLE:

1. $1, 2, 4, 8, 16, \dots$ (common ratio = 2)

2. $3, -3/2, 3/4, -3/8, \dots$ (common ratio = $-1/2$)
 3. $0.1, 0.01, 0.001, 0.0001, \dots$ (common ratio = $0.1 = 1/10$)

GENERAL TERM OF A GEOMETRIC SEQUENCE:

Let a be the first term and r be the common ratio of a geometric sequence. Then the sequence is a, ar, ar^2, ar^3, \dots

If a_i , for $i \geq 1$ represent the terms of the sequence, then

$$a_1 = \text{first term} = a = ar^{1-1}$$

$$a_2 = \text{second term} = ar = ar^{2-1}$$

$$a_3 = \text{third term} = ar^2 = ar^{3-1}$$

.....

.....

$$a_n = \text{nth term} = ar^{n-1}; \text{ for all integers } n \geq 1$$

EXAMPLE:

Find the 8th term of the following geometric sequence

$$4, 12, 36, 108, \dots$$

SOLUTION:

$$\text{Here } a = \text{first term} = 4$$

$$r = \text{common ratio} = \frac{12}{4} = 3$$

$$n = \text{term number} = 8$$

$$a_8 = \text{value of 8th term} = ?$$

$$\text{Since } a_n = ar^{n-1}; \quad n \geq 1$$

$$\Rightarrow a_8 = (4)(3)^{8-1}$$

$$= 4(2187)$$

$$= 8748$$

EXAMPLE:

Which term of the geometric sequence is $1/8$ if the first term is 4 and common ratio $1/2$

SOLUTION:

$$\text{Given } a = \text{first term} = 4$$

$$r = \text{common ratio} = 1/2$$

$$a_n = \text{value of the nth term} = 1/8$$

$$n = \text{term number} = ?$$

$$\text{Since } a_n = ar^{n-1} \quad n \geq 1$$

$$\Rightarrow \frac{1}{8} = 4 \left(\frac{1}{2} \right)^{n-1}$$

$$\Rightarrow \frac{1}{32} = \left(\frac{1}{2} \right)^{n-1}$$

$$\Rightarrow \left(\frac{1}{2} \right)^5 = \left(\frac{1}{2} \right)^{n-1}$$

$$\Rightarrow n-1 = 5 \quad \Rightarrow n = 6$$

Hence $1/8$ is the 6th term of the given G.P.

EXERCISE:

Write the geometric sequence with positive terms whose second term is 9 and fourth term is 1.

SOLUTION:

Let a be the first term and r be the common ratio of the geometric sequence. Then

$$\begin{aligned} & a_n = ar^{n-1} && n \geq 1 \\ \text{Now} & a_2 = ar^{2-1} \\ \Rightarrow & 9 = ar \dots \dots \dots (1) \\ \text{Also} & a_4 = ar^{4-1} \\ & 1 = ar^3 \dots \dots \dots (2) \end{aligned}$$

Dividing (2) by (1), we get,

$$\begin{aligned} & \frac{1}{9} = \frac{ar^3}{ar} \\ \Rightarrow & \frac{1}{9} = r^2 \\ \Rightarrow & r = \frac{1}{3} \quad \left(\text{rejecting } r = -\frac{1}{3} \right) \end{aligned}$$

Substituting $r = 1/3$ in (1), we get

$$\begin{aligned} & 9 = a \left(\frac{1}{3} \right) \\ \Rightarrow & a = 9 \times 3 = 27 \end{aligned}$$

Hence the geometric sequence is

$$27, 9, 3, 1, 1/3, 1/9, \dots$$

SEQUENCES IN COMPUTER PROGRAMMING:

An important data type in computer programming consists of finite sequences known as one-dimensional arrays; a single variable in which a sequence of variables may be stored.

EXAMPLE:

The names of k students in a class may be represented by an array of k elements “name” as:

$$\text{name}[0], \quad \text{name}[1], \quad \text{name}[2], \quad \dots, \quad \text{name}[k-1]$$

Lecture No.20 Series

SERIES:

The sum of the terms of a sequence forms a series. If a_1, a_2, a_3, \dots represent a sequence of numbers, then the corresponding series is

$$a_1 + a_2 + a_3 + \dots = \sum_{k=1}^{\infty} a_k$$

SUMMATION NOTATION:

The capital Greek letter sigma Σ is used to write a sum in a short hand notation.

where k varies from 1 to n represents the sum given in expanded form by

$$= a_1 + a_2 + a_3 + \dots + a_n$$

More generally if m and n are integers and $m \leq n$, then the summation from k equal m to n of a_k is

$$\sum_{k=m}^n a_k = a_m + a_{m+1} + a_{m+2} + \dots + a_n$$

Here **k** is called the index of the summation; **m** the lower limit of the summation and **n** the upper limit of the summation.

COMPUTING SUMMATIONS:

Let $a_0 = 2, a_1 = 3, a_2 = -2, a_3 = 1$ and $a_4 = 0$. Compute each of the summations:

$$1. \quad \sum_{i=0}^4 a_i \qquad 2. \quad \sum_{j=0}^2 a_{2j} \qquad \sum_{k=1}^1 a_k$$

SOLUTION:

$$1. \quad \sum_{i=0}^4 a_i = a_0 + a_1 + a_2 + a_3 + a_4 \\ = 2 + 3 + (-2) + 1 + 0 = 4$$

$$2. \quad \sum_{j=0}^2 a_{2j} = a_0 + a_2 + a_4 \\ = 2 + (-2) + 0 = 0$$

$$3. \quad \sum_{k=1}^1 a_k = a_1 \\ = 3$$

EXERCISE:

Compute the summations

$$1. \quad \sum_{i=1}^3 (2i-1) = [2(1)-1] + [2(2)-1] + [2(3)-1] \\ = 1 + 3 + 5 \\ = 9$$

$$2. \quad \sum_{k=-1}^1 (k^3 + 2) = [(-1)^3 + 2] + [(0)^3 + 2] + [(1)^3 + 2] \\ = [-1 + 2] + [0 + 2] + [1 + 2] \\ = 1 + 2 + 3 \\ = 6$$

SUMMATION NOTATION TO EXPANDED FORM:

Write the summation $\sum_{i=0}^n \frac{(-1)^i}{i+1}$ to expanded form:

SOLUTION:

$$\begin{aligned}\sum_{i=0}^n \frac{(-1)^i}{i+1} &= \frac{(-1)^0}{0+1} + \frac{(-1)^1}{1+1} + \frac{(-1)^2}{2+1} + \frac{(-1)^3}{3+1} + \cdots + \frac{(-1)^n}{n+1} \\ &= \frac{1}{1} + \frac{(-1)}{2} + \frac{1}{3} + \frac{(-1)}{4} + \cdots + \frac{(-1)^n}{n+1} \\ &= 1 - \frac{1}{2} + \frac{1}{3} - \frac{1}{4} + \cdots + \frac{(-1)^n}{n+1}\end{aligned}$$

EXPANDED FORM TO SUMMATION NOTATION:

Write the following using summation notation:

$$1. \quad \frac{1}{n} + \frac{2}{n+1} + \frac{3}{n+2} + \cdots + \frac{n+1}{2n}$$

SOLUTION:

We find the kth term of the series.

The numerators forms an arithmetic sequence 1, 2, 3, ..., n+1, in which

$$a = \text{first term} = 1$$

& d = common difference = 1

$$a_k = a + (k - 1)d$$

$$= 1 + (k - 1)(1) = 1 + k - 1 = k$$

Similarly, the denominators forms an arithmetic sequence

n, n+1, n+2, ..., 2n, in which

$$a = \text{first term} = n$$

$$d = \text{common difference} = 1$$

$$\therefore a_k = a + (k - 1)d$$

$$= n + (k - 1)(1)$$

$$= k + n - 1$$

Hence the kth term of the series is

$$\frac{k}{(n-1)+k}$$

And the expression for the series is given by

$$\begin{aligned}\therefore \frac{1}{n} + \frac{2}{n+1} + \frac{3}{n+2} + \cdots + \frac{n+1}{2n} &= \sum_{k=1}^{n+1} \frac{k}{(n-1)+k} \\ &= \sum_{k=0}^n \frac{k+1}{n+k}\end{aligned}$$

TRANSFORMING A SUM BY A CHANGE OF VARIABLE:

Consider $\sum_{k=1}^n k^2 = 1^2 + 2^2 + 3^2$

and
$$\sum_{i=1}^3 i^2 = 1^2 + 2^2 + 3^2$$

$$\sum_{k=1}^3 k^2 = \sum_{i=1}^3 i^2$$

Hence

The index of a summation can be replaced by any other symbol. The index of a summation is therefore called a dummy variable.

EXERCISE:

Consider

$$\sum_{k=1}^{n+1} \frac{k}{(n-1)+k}$$

Substituting $k = j + 1$ so that $j = k - 1$

When $k = 1$, $j = k - 1 = 1 - 1 = 0$

When $k = n + 1$, $j = k - 1 = (n + 1) - 1 = n$

Hence

$$\sum_{k=1}^{n+1} \frac{k}{(n-1)+k} = \sum_{j=0}^n \frac{j+1}{(n-1)+(j+1)}$$

$$= \sum_{j=0}^n \frac{j+1}{n+j} = \sum_{k=0}^n \frac{k+1}{n+k} \quad (\text{changing variable})$$

EXERCISE:

Transform by making the change of variable $j = i - 1$, in the summation

$$\sum_{i=1}^{n-1} \frac{i}{(n-i)^2}$$

SOLUTION:

Set $j = i - 1$ so that $i = j + 1$

when $i = 1$

$$j = i - 1 = 1 - 1 = 0$$

when $i = n - 1$

$$j = i - 1 = (n - 1) - 1 = n - 2$$

$$\begin{aligned} \therefore \sum_{i=1}^{n-1} \frac{i}{(n-i)^2} &= \sum_{j=0}^{n-2} \frac{j+1}{(n-(j+1))^2} \\ &= \sum_{j=0}^{n-2} \frac{j+1}{(n-j-1)^2} \end{aligned}$$

PROPERTIES OF SUMMATIONS:

$$1. \sum_{k=m}^n (a_k + b_k) = \sum_{k=m}^n a_k + \sum_{k=m}^n b_k; \quad a_k, b_k \in \mathbb{R}$$

$$2. \sum_{k=m}^n c a_k = c \sum_{k=m}^n a_k \quad c \in \mathbb{R}$$

$$3. \sum_{k=a-i}^{b-i} (k+i) = \sum_{k=a}^b k \quad i \in N$$

$$4. \sum_{k=a+i}^{b+i} (k-i) = \sum_{k=a}^b k \quad i \in N$$

$$5. \sum_{k=1}^n c = c + c + \dots + c = nc$$

EXERCISE:

Express the following summation more simply: $3 \sum_{k=1}^n (2k-3) + \sum_{k=1}^n (4-5k)$

SOLUTION:

$$\begin{aligned} & 3 \sum_{k=1}^n (2k-3) + \sum_{k=1}^n (4-5k) \\ &= 3 \sum_{k=1}^n (2k-3) + \sum_{k=1}^n (4-5k) \\ &= 3 \sum_{k=1}^n (2k-3) + \sum_{k=1}^n (4-5k) \\ &= \sum_{k=1}^n [3(2k-3) + (4-5k)] \\ &= \sum_{k=1}^n (k-5) \\ &= \sum_{k=1}^n k - \sum_{k=1}^n 5 \\ &= \sum_{k=1}^n k - 5n \end{aligned}$$

ARITHMETIC SERIES:

The sum of the terms of an arithmetic sequence forms an arithmetic series (A.S). For example

$$1 + 3 + 5 + 7 + \dots$$

is an arithmetic series of positive odd integers.

In general, if a is the first term and d the common difference of an arithmetic series, then the series is given as: $a + (a+d) + (a+2d) + \dots$

SUM OF n TERMS OF AN ARITHMETIC SERIES:

Let a be the first term and d be the common difference of an arithmetic series. Then its n th term is:

$$a_n = a + (n-1)d; \quad n \geq 1$$

If S_n denotes the sum of first n terms of the A.S, then

$$\begin{aligned} S_n &= a + (a+d) + (a+2d) + \dots + [a + (n-1)d] \\ &= a + (a+d) + (a+2d) + \dots + a_n \\ &= a + (a+d) + (a+2d) + \dots + (a_n - d) + a_n \dots \dots \dots (1) \end{aligned}$$

where $a_n = a + (n-1)d$

Rewriting the terms in the series in reverse order,

$$S_n = a_n + (a_n - d) + (a_n - 2d) + \dots + (a + d) + a \dots\dots\dots(2)$$

Adding (1) and (2) term by term, gives

$$\begin{aligned} 2 S_n &= (a + a_n) + (a + a_n) + (a + a_n) + \dots + (a + a_n) \quad (n \text{ terms}) \\ 2 S_n &= n (a + a_n) \\ \Rightarrow S_n &= n(a + a_n)/2 \\ S_n &= n(a + 1)/2 \dots\dots\dots(3) \end{aligned}$$

Where

$$1 = a_n = a + (n - 1)d$$

Therefore

$$\begin{aligned} S_n &= n/2 [a + a + (n - 1) d] \\ S_n &= n/2 [2 a + (n - 1) d] \dots\dots\dots(4) \end{aligned}$$

EXERCISE:

Find the sum of first n natural numbers.

SOLUTION:

Let $S_n = 1 + 2 + 3 + \dots + n$

Clearly the right hand side forms an arithmetic series with

$$a = 1, \quad d = 2 - 1 = 1 \quad \text{and} \quad n = n$$

$$\begin{aligned} \therefore S_n &= \frac{n}{2} [2a + (n-1)d] \\ &= \frac{n}{2} [2(1) + (n-1)(1)] \\ &= \frac{n}{2} [2 + n - 1] \\ &= \frac{n(n+1)}{2} \end{aligned}$$

EXERCISE:

Find the sum of all two digit positive integers which are neither divisible by 5 nor by 2.

SOLUTION:

The series to be summed is:

$$11 + 13 + 17 + 19 + 21 + 23 + 27 + 29 + \dots + 91 + 93 + 97 + 99$$

which is not an arithmetic series.

If we make group of four terms we get

$$(11 + 13 + 17 + 19) + (21 + 23 + 27 + 29) + (31 + 33 + 37 + 39) + \dots + (91 + 93 + 97 + 99) = 60 + 100 + 140 + \dots + 380$$

which now forms an arithmetic series in which

$$a = 60; \quad d = 100 - 60 = 40 \quad \text{and} \quad 1 = a_n = 380$$

To find n, we use the formula

$$\begin{aligned} a_n &= a + (n - 1) d \\ \Rightarrow 380 &= 60 + (n - 1) (40) \\ \Rightarrow 380 - 60 &= (n - 1) (40) \\ \Rightarrow 320 &= (n - 1) (40) \\ \frac{320}{40} &= n - 1 \end{aligned}$$

$$\Rightarrow \begin{array}{l} 8 = n - 1 \\ n = 9 \end{array}$$

Now

$$S_n = \frac{n}{2}(a+l)$$

$$\therefore S_9 = \frac{9}{2}(60+380) = 1980$$

GEOMETRIC SERIES:

The sum of the terms of a geometric sequence forms a geometric series (G.S.). For example

$$1 + 2 + 4 + 8 + 16 + \dots$$

is geometric series.

In general, if **a** is the first term and **r** the common ratio of a geometric series, then the series is given as: $a + ar + ar^2 + ar^3 + \dots$

SUM OF n TERMS OF A GEOMETRIC SERIES:

Let **a** be the first term and **r** be the common ratio of a geometric series. Then its nth term is:

$$a_n = ar^{n-1}; \quad n \geq 1$$

If S_n denotes the sum of first n terms of the G.S. then

$$S_n = a + ar + ar^2 + ar^3 + \dots + ar^{n-2} + ar^{n-1} \dots \dots \dots (1)$$

Multiplying both sides by r we get.

$$r S_n = ar + ar^2 + ar^3 + \dots + ar^{n-1} + ar^n \dots \dots \dots (2)$$

Subtracting (2) from (1) we get

$$S_n - rS_n = a - ar^n$$

$$\Rightarrow (1 - r) S_n = a(1 - r^n)$$

$$\Rightarrow S_n = \frac{a(1 - r^n)}{1 - r} \quad (r \neq 1)$$

EXERCISE:

Find the sum of the geometric series

$$6 - 2 + \frac{2}{3} - \frac{2}{9} + \dots + \text{to 10 terms}$$

SOLUTION:

In the given geometric series

$$a = 6, \quad r = \frac{-2}{6} = -\frac{1}{3} \quad \text{and } n = 10$$

$$\begin{aligned} \therefore S_n &= \frac{a(1-r^n)}{1-r} \\ S_{10} &= \frac{6\left(1-\left(-\frac{1}{3}\right)^{10}\right)}{1-\left(-\frac{1}{3}\right)} = \frac{6\left(1+\frac{1}{3^{10}}\right)}{\left(\frac{4}{3}\right)} \\ &= \frac{9\left(1+\frac{1}{3^{10}}\right)}{2} \end{aligned}$$

INFINITE GEOMETRIC SERIES:

Consider the infinite geometric series

$$a + ar + ar^2 + \dots + ar^{n-1} + \dots$$

then

$$S_n = a + ar + ar^2 + \dots + ar^{n-1} = \frac{a(1-r^n)}{1-r} \quad (r \neq 1)$$

If $S_n \rightarrow S$ as $n \rightarrow \infty$, then the series is convergent and S is its sum.

If $|r| < 1$, then $r^n \rightarrow 0$ as $n \rightarrow \infty$

$$\begin{aligned} \therefore S &= \lim_{n \rightarrow \infty} S_n = \lim_{n \rightarrow \infty} \frac{a(1-r^n)}{1-r} \\ &= \frac{a}{1-r} \end{aligned}$$

If S_n increases indefinitely as n becomes very large then the series is said to be divergent.

EXERCISE:

Find the sum of the infinite geometric series:

$$\frac{9}{4} + \frac{3}{2} + 1 + \frac{2}{3} + \dots$$

SOLUTION:

Here we have

$$a = \frac{9}{4}, \quad r = \frac{3/2}{9/4} = \frac{2}{3}$$

Note that $|r| < 1$ So we can use the above formula.

$$\begin{aligned} \therefore S &= \frac{a}{1-r} \\ &= \frac{9/4}{1-2/3} \\ &= \frac{9/4}{1/3} = \frac{9}{4} \times \frac{3}{1} = \frac{27}{4} \end{aligned}$$

EXERCISE:

Find a common fraction for the recurring decimal 0.81

SOLUTION:

$$\begin{aligned} 0.81 &= 0.8181818181 \dots \\ &= 0.81 + 0.0081 + 0.000081 + \dots \end{aligned}$$

which is an infinite geometric series with

$$a = 0.81, \quad r = \frac{0.0081}{0.81} = 0.01$$

$$\begin{aligned} \therefore \text{Sum} &= \frac{a}{1-r} \\ &= \frac{0.81}{1-0.01} = \frac{0.81}{0.99} \\ &= \frac{81}{99} = \frac{9}{11} \end{aligned}$$

IMPORTANT SUMS:

$$1. \quad 1 + 2 + 3 + \dots + n = \sum_{k=1}^n k = \frac{n(n+1)}{2}$$

$$2. \quad 1^2 + 2^2 + 3^2 + \dots + n^2 = \sum_{k=1}^n k^2 = \frac{n(n+1)(2n+1)}{6}$$

$$3. \quad 1^3 + 2^3 + 3^3 + \dots + n^3 = \sum_{k=1}^n k^3 = \frac{n^2(n+1)}{4} = \left[\frac{n(n+1)}{2} \right]^2$$

EXERCISE:

Sum to n terms the series $1 \cdot 5 + 5 \cdot 11 + 9 \cdot 17 + \dots$

SOLUTION:

Let T_k denote the kth term of the given series.

$$\begin{aligned} \text{Then } T_k &= [1+(k-1)4] [5+(k-1)6] \\ &= (4k-3)(6k-1) \\ &= 24k^2 - 22k + 3 \end{aligned}$$

$$\text{Now } S_k = T_1 + T_2 + T_3 + \dots + T_n$$

$$\begin{aligned} &= \sum_{k=1}^n T_k \\ &= \sum_{k=1}^n (24k^2 - 22k + 3) \end{aligned}$$

$$\begin{aligned} &= 24 \sum_{k=1}^n k^2 - 22 \sum_{k=1}^n k + \sum_{k=1}^n 3 \\ &= 24 \left(\frac{n(n+1)(2n+1)}{6} \right) - 22 \left(\frac{n(n+1)}{2} \right) + 3n \\ &= n[(8n^2 + 12n + 4) - (11n + 11) + 3] \end{aligned}$$

Lecture No.21 Recursion I

Recursion

First of all instead of giving the definition of Recursion we give you an example, you already know the Set of Odd numbers Here we give the new definition of the same set that is the set of Odd numbers.

Definition for odd positive integers may be given as:

BASE:

1 is an odd positive integer.

RECURSION:

If k is an odd positive integer, then $k + 2$ is an odd positive integer.

Now, 1 is an odd positive integer by the definition base.

With $k = 1$, $1 + 2 = 3$, so 3 is an odd positive integer.

With $k = 3$, $3 + 2 = 5$, so 5 is an odd positive integer

and so, 7, 9, 11, ... are odd positive integers.

REMARK: Recursive definitions can be used in a “generative” manner.

RECURSION:

The process of defining an object in terms of smaller versions of itself is called recursion.

A recursive definition has two parts:

1.BASE:

An initial simple definition which **cannot** be expressed in terms of smaller versions of itself.

2. RECURSION:

The part of definition which **can** be expressed in terms of smaller versions of itself.

RECURSIVELY DEFINED FUNCTIONS:

A function is said to be recursively defined if the function refers to itself such that

1. There are certain arguments, called base values, for which the function does not refer to itself.
2. Each time the function does refer to itself, the argument of the function must be closer to a base value.

EXAMPLE:

Suppose that f is defined recursively by

$$f(0) = 3$$

$$f(n + 1) = 2 f(n) + 3$$

Find $f(1)$, $f(2)$, $f(3)$ and $f(4)$

SOLUTION:

From the recursive definition it follows that

$$f(1) = 2 f(0) + 3 = 2(3) + 3 = 6 + 3 = 9$$

In evaluating of $f(1)$ we use the formula given in the example and we note that it involves $f(0)$ and we are also given the value of that which we use to find out the functional value at 1. Similarly we will use the preceding value

In evaluating the next values of the functions as we did below.

$$f(2) = 2 f(1) + 3 = 2(9) + 3 = 18 + 3 = 21$$

$$f(3) = 2 f(2) + 3 = 2(21) + 3 = 42 + 3 = 45$$

$$f(4) = 2 f(3) + 3 = 2(45) + 3 = 90 + 3 = 93$$

EXERCISE:

Find $f(2)$, $f(3)$, and $f(4)$ if f is defined recursively by
 $f(0) = -1$, $f(1) = 2$ and for $n = 1, 2, 3, \dots$
 $f(n+1) = f(n) + 3 f(n - 1)$

SOLUTION:

From the recursive definition it follows that

$$\begin{aligned} f(2) &= f(1) + 3 f(1-1) \\ &= f(1) + 3 f(0) \\ &= 2 + 3 (-1) \\ &= -1 \end{aligned}$$

Now in order to find out the other values we will need the values of the preceding. So we write these values here again

$$\begin{aligned} f(0) &= -1, f(1) = 2 & f(n+1) &= f(n) + 3 f(n - 1) \\ f(2) &= -1 \end{aligned}$$

By recursive formula we have

$$\begin{aligned} f(3) &= f(2) + 3 f(2-1) \\ &= f(2) + 3 f(1) \\ &= (-1) + 3 (2) \\ &= 5 \\ f(4) &= f(3) + 3 f(3-1) \\ &= f(2) + 3 f(2) \\ &= 5 + 3 (-1) \\ &= 2 \end{aligned}$$

THE FACTORIAL OF A POSITIVE INTEGER:

For each positive integer n , the factorial of n denoted $n!$ is defined to be the product of all the integers from 1 to n :

$$n! = n \cdot (n - 1) \cdot (n - 2) \cdots 3 \cdot 2 \cdot 1$$

Zero factorial is defined to be 1

$$0! = 1$$

EXAMPLE:

$$\begin{array}{ll} 0! = 1 & 1! = 1 \\ 2! = 2 \cdot 1 = 2 & 3! = 3 \cdot 2 \cdot 1 = 6 \\ 4! = 4 \cdot 3 \cdot 2 \cdot 1 = 24 & 5! = 5 \cdot 4 \cdot 3 \cdot 2 \cdot 1 = 120 \\ 6! = 6 \cdot 5 \cdot 4 \cdot 3 \cdot 2 \cdot 1 = 720 & 7! = 7 \cdot 6 \cdot 5 \cdot 4 \cdot 3 \cdot 2 \cdot 1 = 5040 \end{array}$$

REMARK:

$$\begin{aligned} 5! &= 5 \cdot 4 \cdot 3 \cdot 2 \cdot 1 \\ &= 5 \cdot (4 \cdot 3 \cdot 2 \cdot 1) \\ &= 5 \cdot 4! \end{aligned}$$

In general,

$$n! = n(n-1)! \quad \text{for each positive integer } n.$$

THE FACTORIAL FUNCTION DEFINED RECURSIVELY:

We can define the factorial function $F(n) = n!$ recursively by specifying the initial value of this function, namely, $F(0) = 1$, and giving a rule for finding $F(n)$ from $F(n-1)$. $\{n! = n(n-1)!\}$

Thus, the recursive definition of factorial function $F(n)$ is:

1. $F(0) = 1$
2. $F(n) = n F(n-1)$

EXERCISE:

Let S be the function such that $S(n)$ is the sum of the first n positive integers. Give a recursive definition of $S(n)$.

SOLUTION:

The initial value of this function may be specified as $S(0) = 0$

Since

$$\begin{aligned} S(n) &= n + (n - 1) + (n - 2) + \dots + 3 + 2 + 1 \\ &= n + [(n - 1) + (n - 2) + \dots + 3 + 2 + 1] \\ &= n + S(n-1) \end{aligned}$$

which defines the recursive step.

Accordingly S may be defined as:

1. $S(0) = 0$
2. $S(n) = n + S(n - 1)$ for $n \geq 1$

EXERCISE:

Let a and b denote positive integers. Suppose a function Q is defined recursively as follows:

- (a) Find the value of $Q(2,3)$ and $Q(14,3)$
- (b) What does this function do? Find $Q(3355, 7)$

SOLUTION:

$$Q(a,b) = \begin{cases} 0 & \text{if } a < b \\ Q(a-b,b) + 1 & \text{if } b \leq a \end{cases}$$

- (a) $Q(2,3) = 0$ since $2 < 3$
Given $Q(a,b) = Q(a-b,b) + 1$ if $b \leq a$

Now

$$\begin{aligned} Q(14, 3) &= Q(11,3) + 1 \\ &= [Q(8,3) + 1] + 1 = Q(8,3) + 2 \\ &= [Q(5,3) + 1] + 2 = Q(5,3) + 3 \\ &= [Q(2,3) + 1] + 3 = Q(2,3) + 4 \\ &= 0 + 4 \quad (\because Q(2,3) = 0) \\ &= 4 \end{aligned}$$

- (b) $Q(a,b) = \begin{cases} 0 & \text{if } a < b \\ Q(a-b,b) + 1 & \text{if } b \leq a \end{cases}$

Each time b is subtracted from a , the value of Q is increased by 1. Hence $Q(a,b)$ finds the integer quotient when a is divided by b .

Thus $Q(3355, 7) = 479$

THE FIBONACCI SEQUENCE:

The Fibonacci sequence is defined as follows.

$$F_0 = 1, F_1 = 1$$

$$F_k = F_{k-1} + F_{k-2} \quad \text{for all integers } k \geq 2$$

$$F_2 = F_1 + F_0 = 1 + 1 = 2$$

$$F_3 = F_2 + F_1 = 2 + 1 = 3$$

$$F_4 = F_3 + F_2 = 3 + 2 = 5$$

$$F_5 = F_4 + F_3 = 5 + 3 = 8$$

⋮
⋮
⋮

RECURRENCE RELATION:

A recurrence relation for a sequence a_0, a_1, a_2, \dots , is a formula that relates each term a_k to certain of its predecessors $a_{k-1}, a_{k-2}, \dots, a_{k-i}$,

where i is a fixed integer and k is any integer greater than or equal to i . The initial conditions for such a recurrence relation specify the values of

$a_0, a_1, a_2, \dots, a_{i-1}$.

EXERCISE:

Find the first four terms of the following recursively defined sequence.

$$b_1 = 2$$

$$b_k = b_{k-1} + 2 \cdot k, \quad \text{for all integers } k \geq 2$$

SOLUTION:

$$b_1 = 2 \quad (\text{given in base step})$$

$$b_2 = b_1 + 2 \cdot 2 = 2 + 4 = 6$$

$$b_3 = b_2 + 2 \cdot 3 = 6 + 6 = 12$$

$$b_4 = b_3 + 2 \cdot 4 = 12 + 8 = 20$$

EXERCISE:

Find the first five terms of the following recursively defined sequence.

$$t_0 = -1, \quad t_1 = 1$$

$$t_k = t_{k-1} + 2 \cdot t_{k-2}, \quad \text{for all integers } k \geq 2$$

SOLUTION:

$$t_0 = -1, \quad (\text{given in base step})$$

$$t_1 = 1 \quad (\text{given in base step})$$

$$t_2 = t_1 + 2 \cdot t_0 = 1 + 2 \cdot (-1) = 1 - 2 = -1$$

$$t_3 = t_2 + 2 \cdot t_1 = -1 + 2 \cdot 1 = -1 + 2 = 1$$

$$t_4 = t_3 + 2 \cdot t_2 = 1 + 2 \cdot (-1) = 1 - 2 = -1$$

EXERCISE:

Define a sequence b_0, b_1, b_2, \dots by the formula

$$b_n = 5^n, \quad \text{for all integers } n \geq 0.$$

Show that this sequence satisfies the recurrence relation $b_k = 5b_{k-1}$, for all integers $k \geq 1$.

SOLUTION:

The sequence is given by the formula

$$b_n = 5^n$$

Substituting k for n we get

$$b_k = 5^k \dots \dots (1)$$

Substituting $k - 1$ for n we get

$$b_{k-1} = 5^{k-1} \quad \dots \dots (2)$$

Multiplying both sides of (2) by 5 we obtain

$$\begin{aligned} 5 \cdot b_{k-1} &= 5 \cdot 5^{k-1} \\ &= 5^k = b_k \quad \text{using (1)} \end{aligned}$$

Hence $b_k = 5b_{k-1}$ as required

EXERCISE:

Show that the sequence $0, 1, 3, 7, \dots, 2^n - 1, \dots$, for $n \geq 0$, satisfies the recurrence relation

$$d_k = 3d_{k-1} - 2d_{k-2}, \text{ for all integers } k \geq 2$$

SOLUTION:

The sequence is given by the formula

$$d_n = 2^n - 1 \quad \text{for } n \geq 0$$

Substituting $k - 1$ for n we get $d_{k-1} = 2^{k-1} - 1$

Substituting $k - 2$ for n we get $d_{k-2} = 2^{k-2} - 1$

We want to prove that

$$\begin{aligned} d_k &= 3d_{k-1} - 2d_{k-2} \\ \text{R.H.S.} &= 3(2^k - 1 - 1) - 2(2^k - 2 - 1) \\ &= 3 \cdot 2^k - 1 - 3 - 2 \cdot 2^k - 2 + 2 \\ &= 3 \cdot 2^k - 1 - 2^k - 1 - 1 \\ &= (3 - 1) \cdot 2^k - 1 - 1 \\ &= 2 \cdot 2^k - 1 - 1 = 2^k - 1 = d_k = \text{L.H.S.} \end{aligned}$$

THE TOWER OF HANOI:

The puzzle was invented by a French Mathematician Adouard Lucas in 1883. It is well known to students of Computer Science since it appears in virtually any introductory text on data structures or algorithms.

There are three poles on first of which are stacked a number of disks that decrease in size as they rise from the base. The goal is to transfer all the disks one by one from the first pole to one of the others, but they must never place a larger disk on top of a smaller one. Let m_n be the minimum number of moves needed to move a tower of n disks from one pole to another. Then m_n can be obtained recursively as follows.

- $m_1 = 1$
- $m_k = 2 m_{k-1} + 1$

$$m_2 = 2 \cdot m_1 + 1 = 2 \cdot 1 + 1 = 3$$

$$m_3 = 2 \cdot m_2 + 1 = 2 \cdot 3 + 1 = 7$$

$$m_4 = 2 \cdot m_3 + 1 = 2 \cdot 7 + 1 = 15$$

$$m_5 = 2 \cdot m_4 + 1 = 2 \cdot 15 + 1 = 31$$

$$m_6 = 2 \cdot m_5 + 1 = 2 \cdot 31 + 1 = 65$$

Note that

$$m_n = 2^n - 1$$

$$m_{64} = 2^{64} - 1$$
$$\cong 584.5 \text{ billion years}$$

USE OF RECURSION:

At first recursion may seem hard or impossible, may be magical at best. However, recursion often provides elegant, short algorithmic solutions to many problems in computer science and mathematics.

Examples where recursion is often used

- math functions
- number sequences
- data structure definitions
- data structure manipulations
- language definitions

Lecture No.22 Recursion II

Recursion

A recursive definition (i.e to build the new set elements from the previous one,s)for a set consists of the following three rules:

- I. **BASE:** A statement that certain objects belong to the set.
- II. **RECURSION:** A collection of rules indicating how to form new set objects from those already known to be in the set.
- III. **RESTRICTION:** A statement that no objects belong to the set other than those coming from I and II.

EXERCISE

Let S be a set defined recursively by

- I. **BASE:** $5 \in S$.
- II. **RECURSION:** If $x \in S$ and $y \in S$, then $x + y \in S$.
- III. **RESTRICTION:** S contains no elements other than those obtained from rules I and II.

Show that S is the subset of all positive integers divisible by 5.

SOLUTION

Let A be the set of all positive integers divisible by 5. Then

$$A = \{5n \mid n \in \mathbb{N}\}.$$

We need to prove that $S \subseteq A$.

5 is divisible by 5 since $5 = 5 \times 1$

$$\Rightarrow 5 \in A$$

Now consider $x \in A$ and $y \in A$, we show that $x + y \in A$

$$x \in A \Rightarrow 5 \mid x \text{ so that } x = 5 \cdot p \quad \text{for some } p \in \mathbb{N}$$

$$y \in A \Rightarrow 5 \mid y \text{ so that } y = 5 \cdot q \quad \text{for some } q \in \mathbb{N}$$

Hence $x + y = 5 \cdot p + 5 \cdot q = 5 \cdot (p + q)$

$$\Rightarrow 5 \mid (x + y) \text{ and so } (x + y) \in A$$

Thus, S is a subset of A.

RECURSIVE DEFINITION OF BOOLEAN EXPRESSIONS

I. BASE:

Each symbol of the alphabet is a Boolean expression.

II. RECURSION:

If P and Q are Boolean Expressions, then so are

- (a) $(P \wedge Q)$
- (b) $(P \vee Q)$ and
- (c) $\sim P$.

III RESTRICTION:

There are no Boolean expressions over the alphabet other than those obtained from I and II.

EXERCISE

Show that the following is a Boolean expression over the English alphabet.

$$((p \vee q) \vee \sim ((p \wedge \sim s) \wedge r))$$

SOLUTION

We will show that the given Boolean expression can be found out using the recursive definition of Boolean expressions. So first of all we will start with the symbols which are involved in the Boolean expressions.

(1) p, q, r, and s are Boolean expressions by I.

Now we start with the inner most expression which is $p \wedge \sim s$ before we check this one we will check $\sim s$ and we note that

(2) $\sim s$ is a Boolean expressions by (1) and II(c).

Now from above we have p and $\sim s$ are Boolean expressions and we can say that

(3) $(p \wedge \sim s)$ is a Boolean expressions by (1), (2) and II(a).

Similarly we find that

(4) $(p \wedge \sim s) \wedge r$ is a Boolean expressions by (1), (3) and II(a).

(5) $\sim (p \wedge \sim s) \wedge r$ is a Boolean expressions by (4) and II(c).

(6) $(p \vee q)$ is a Boolean expressions by (1) and II(b).

(7) $((p \vee q) \vee \sim ((p \wedge \sim s) \wedge r))$ is a Boolean expressions by (5), (6) and II(b).

RECURSIVE DEFINITION OF THE SET OF STRINGS OVER AN ALPHABET

Consider a finite alphabet $\Sigma = \{a, b\}$. The set of all finite strings over Σ , denoted Σ^* , is defined recursively as follows:

I. **BASE:** ε is in Σ^* , where ε is the null string.

II. **RECURSION:** If $s \in \Sigma^*$, then

- (a) $sa \in \Sigma^*$ and
- (b) $sb \in \Sigma^*$,

where sa and sb are concatenations of s with a and b respectively.

III. **RESTRICTION:** Nothing is in Σ^* other than objects defined in I and II above.

EXERCISE

Give derivations showing that abb is in Σ^* .

SOLUTION

- (1) $\varepsilon \in \Sigma^*$ by I.
- (2) $a = \varepsilon a \in \Sigma^*$ by (1) and II(a).
- (3) $ab \in \Sigma^*$ by (2) and II(b).
- (4) $abb \in \Sigma^*$ by (3) and II(b).

EXERCISE

Give a recursive definition of all strings of 0's and 1's for which all the 0's precede all the 1's.

SOLUTION

Let S be the set of all strings of 0's and 1's for which all the 0's precede all the 1's. The following is a recursive definition of S .

- I. **BASE:** The null string $\varepsilon \in S$.
- II. **RECURSION:** If $s \in S$, then
 - (a) $0s \in S$ and (b) $s1 \in S$.
- III. **RESTRICTION:** Nothing is in S other than objects defined in I and II above.

PARENTHESIS STRUCTURE

Let P be the set of grammatical configurations of parentheses. The following is a recursive definition of P .

- I. **BASE:** $()$ is in P .
- II. **RECURSION:**
 - (a) If E is in P , so is (E) .
 - (b) If E and F are in P , so is EF .
- III. **RESTRICTION:** No configurations of parentheses are in P other than those derived from I and II above.

EXERCISE

Derive the fact that $((())())$ is in the set P of grammatical configuration of parentheses.

SOLUTION

Now we will show that the given structure of parenthesis can be obtained by using the recursive definition of Parenthesis Structure for this we will start with the inner most bracket and note that

1. $()$ is in P, by I

Since in the recursive step (a) we say that parenthesis can be put into another parenthesis which shows that

2. $(())$ is in P, by 1 and II(a)

Similarly you can see that

3. $((()) ())$ is in P, by 2, I and II(b)

4. $(((()) ()) ())$ is in P, by 3, and II(a)

SET OF ARITHMETIC EXPRESSIONS

The set of arithmetic expressions over the real numbers can be defined recursively as follows.

I. **BASE:** Each real number r is an arithmetic expression.

II. **RECURSION:** If u and v are arithmetic expressions, then the following are also arithmetic expressions.

a. $(+ u)$

b. $(- u)$

c. $(u + v)$

d. $(u - v)$

e. $(u \cdot v)$

f. $\left(\frac{u}{v} \right)$

EXERCISE

Give derivations showing that the following is an arithmetic expression.

$$\left(\frac{(9 \cdot (6.1 + 2))}{((4 - 7) \cdot 6)} \right)$$

SOLUTION; Here again our approach is same that we will trace the given expression and see that it can be obtained by using Recursive definition of Arithmetic Operations or not.

(1) 9, 6.1, 2, 4, 7, and 6 are arithmetic expressions by I.

(2) $(6.1 + 2)$ is an arithmetic expression by (1) and II(c).

(3) $(9 \cdot (6.1 + 2))$ is an arithmetic expression by (1), (2) and II(e).

(4) $(4 - 7)$ is an arithmetic expression by (1) and II(d).

(5) $((4 - 7) \cdot 6)$ is an arithmetic expression by (1), (4) and II(e).

(6)

$$\left(\frac{(9 \cdot (6.1 + 2))}{((4 - 7) \cdot 6)} \right)$$

is an arithmetic expression by (3), (5) and II(f).

RECURSIVE DEFINITION OF SUM

Given numbers a_1, a_2, \dots, a_n , where n is a positive integer, the

summation from $i = 1$ to n of the a_i , denoted $\sum_{i=1}^n a_i$, is defined as follows:

RECURSIVE DEFINITION OF UNION OF SETS

Given sets A_1, A_2, \dots, A_n , where n is a positive integer, the union of A_i from $i = 1$ to n , denoted

$$\bigcup_{i=1}^n A_i \text{ is defined by}$$

BASE :

$$\bigcup_{i=1}^1 A_i = A_1$$

RECURSION:

$$\bigcup_{i=1}^n A_i = \left(\bigcup_{i=1}^{n-1} A_i \right) \cup A_n.$$

RECURSIVE DEFINITION OF INTERSECTION OF SETS

Given sets A_1, A_2, \dots, A_n , where n is a positive integer, the intersection of A_i from $i = 1$ to n , denoted

$$\bigcap_{i=1}^n A_i, \text{ is defined by}$$

BASE :

$$\bigcap_{i=1}^1 A_i = A_1$$

RECURSION:

$$\bigcap_{i=1}^n A_i = \left(\bigcap_{i=1}^{n-1} A_i \right) \cap A_n.$$

Lecture No.23 Mathematical induction

PRINCIPLE OF MATHEMATICAL INDUCTION:

Let $P(n)$ be a propositional function defined for all positive integers n . $P(n)$ is true for every positive integer n if

1.Basis Step:

The proposition $P(1)$ is true.

2.Inductive Step:

If $P(k)$ is true then $P(k + 1)$ is true for all integers $k \geq 1$.

i.e. $\forall k \quad p(k) \rightarrow P(k + 1)$

EXAMPLE:

Use Mathematical Induction to prove that

$$1 + 2 + 3 + \dots + n = \frac{n(n+1)}{2} \quad \text{for all integers } n \geq 1$$

SOLUTION:

$$\text{Let } P(n): 1 + 2 + 3 + \dots + n = \frac{n(n+1)}{2}$$

1.Basis Step:

$P(1)$ is true.

For $n = 1$, left hand side of $P(1)$ is the sum of all the successive integers starting at 1 and ending at 1, so LHS = 1 and RHS is

$$R.H.S = \frac{1(1+1)}{2} = \frac{2}{2} = 1$$

so the proposition is true for $n = 1$.

2. Inductive Step: Suppose $P(k)$ is true for, some integers $k \geq 1$.

$$(1) \quad 1 + 2 + 3 + \dots + k = \frac{k(k+1)}{2}$$

To prove $P(k + 1)$ is true. That is,

$$(2) \quad 1 + 2 + 3 + \dots + (k+1) = \frac{(k+1)(k+2)}{2}$$

Consider L.H.S. of (2)

$$\begin{aligned} 1 + 2 + 3 + \dots + (k+1) &= 1 + 2 + 3 + \dots + k + (k+1) \\ &= \frac{k(k+1)}{2} + (k+1) \quad \text{using (1)} \\ &= (k+1) \left[\frac{k}{2} + 1 \right] \\ &= (k+1) \left[\frac{k+2}{2} \right] \\ &= \frac{(k+1)(k+2)}{2} = \text{RHS of (2)} \end{aligned}$$

Hence by principle of Mathematical Induction the given result true for all integers greater or equal to 1.

EXERCISE:

Use mathematical induction to prove that
 $1+3+5+\dots+(2n-1) = n^2$ for all integers $n \geq 1$.

SOLUTION:

Let $P(n)$ be the equation $1+3+5+\dots+(2n-1) = n^2$

1. Basis Step:

$P(1)$ is true
 For $n = 1$, L.H.S of $P(1) = 1$ and
 R.H.S $= 2(1)-1 = 1$
 Hence the equation is true for $n = 1$

2. Inductive Step:

Suppose $P(k)$ is true for some integer $k \geq 1$. That is,

$$1 + 3 + 5 + \dots + (2k - 1) = k^2 \dots\dots\dots(1)$$

To prove $P(k+1)$ is true; i.e.,

$$1 + 3 + 5 + \dots + [2(k+1)-1] = (k+1)^2 \dots\dots\dots(2)$$

Consider L.H.S. of (2)

$$\begin{aligned} 1 + 3 + 5 + \dots + [2(k+1)-1] &= 1 + 3 + 5 + \dots + (2k+1) \\ &= 1 + 3 + 5 + \dots + (2k-1) + (2k+1) \\ &= k^2 + (2k+1) \quad \text{using (1)} \\ &= (k+1)^2 \\ &= \text{R.H.S. of (2)} \end{aligned}$$

Thus $P(k+1)$ is also true. Hence by mathematical induction, the given equation is true for all integers $n \geq 1$.

EXERCISE:

Use mathematical induction to prove that
 $1+2+2^2 + \dots + 2^n = 2^{n+1} - 1$ for all integers $n \geq 0$

SOLUTION:

Let $P(n)$: $1 + 2 + 2^2 + \dots + 2^n = 2^{n+1} - 1$

1. Basis Step:

$P(0)$ is true.
 For $n = 0$
 L.H.S of $P(0) = 1$
 R.H.S of $P(0) = 2^{0+1} - 1 = 2 - 1 = 1$
 Hence $P(0)$ is true.

2. Inductive Step:Suppose $P(k)$ is true for some integer $k \geq 0$; i.e.,

$$1+2+2^2+\dots+2^k = 2^{k+1} - 1 \dots\dots\dots(1)$$

To prove $P(k+1)$ is true, i.e.,

$$1+2+2^2+\dots+2^{k+1} = 2^{k+1+1} - 1 \dots\dots\dots(2)$$

Consider LHS of equation (2)

$$\begin{aligned} 1+2+2^2+\dots+2^{k+1} &= (1+2+2^2+\dots+2^k) + 2^{k+1} \\ &= (2^{k+1} - 1) + 2^{k+1} \\ &= 2 \cdot 2^{k+1} - 1 \\ &= 2^{k+1+1} - 1 = \text{R.H.S of (2)} \end{aligned}$$

Hence $P(k+1)$ is true and consequently by mathematical induction the given propositional function is true for all integers $n \geq 0$.**EXERCISE:**

Prove by mathematical induction

$$1^2 + 2^2 + 3^2 + \dots + n^2 = \frac{n(n+1)(2n+1)}{6}$$

for all integers $n \geq 1$.

SOLUTION:Let $P(n)$ denotes the given equation**1. Basis step:**

$P(1)$ is true
For $n = 1$
L.H.S of $P(1) = 1^2 = 1$

$$\begin{aligned} \text{R.H.S of } P(1) &= \frac{1(1+1)(2(1)+1)}{6} \\ &= \frac{(1)(2)(3)}{6} = \frac{6}{6} = 1 \end{aligned}$$

So L.H.S = R.H.S of $P(1)$. Hence $P(1)$ is true**2. Inductive Step:**Suppose $P(k)$ is true for some integer $k \geq 1$;

$$1^2 + 2^2 + 3^2 + \dots + k^2 = \frac{k(k+1)(2k+1)}{6} \dots\dots\dots(1)$$

To prove $P(k+1)$ is true; i.e.;

$$1^2 + 2^2 + 3^2 + \dots + (k+1)^2 = \frac{(k+1)(k+1+1)(2(k+1)+1)}{6} \dots\dots\dots(2)$$

Consider LHS of above equation (2)

$$\begin{aligned}
 1^2 + 2^2 + 3^2 + \dots + (k+1)^2 &= 1^2 + 2^2 + 3^2 + \dots + k^2 + (k+1)^2 \\
 &= \frac{k(k+1)(2k+1)}{6} + (k+1)^2 \\
 &= (k+1) \left[\frac{k(2k+1) + 6(k+1)}{6} \right] \\
 &= (k+1) \left[\frac{2k^2 + k + 6k + 6}{6} \right] \\
 &= \frac{(k+1)(2k^2 + 7k + 6)}{6} \\
 &= \frac{(k+1)(k+2)(2k+3)}{6} \\
 &= \frac{(k+1)(k+1+1)(2(k+1)+1)}{6} \\
 &= (k+1) \left[\frac{2k^2 + k + 6k + 6}{6} \right] \\
 &= \frac{(k+1)(2k^2 + 7k + 6)}{6} \\
 &= \frac{(k+1)(k+2)(2k+3)}{6} \\
 &= \frac{(k+1)(k+1+1)(2(k+1)+1)}{6}
 \end{aligned}$$

EXERCISE:

Prove by mathematical induction

$$\frac{1}{1 \cdot 2} + \frac{1}{2 \cdot 3} + \dots + \frac{1}{n(n+1)} = \frac{n}{n+1} \quad \text{for all integers } n \geq 1$$

SOLUTION:

Let P(n) be the given equation.

1. Basis Step:

P(1) is true

For n = 1

$$\text{L.H.S of P(1)} = \frac{1}{1 \cdot 2} = \frac{1}{1 \times 2} = \frac{1}{2}$$

$$\text{R.H.S of P(1)} = \frac{1}{1+1} = \frac{1}{2}$$

Hence P(1) is true

2. Inductive Step:

Suppose $P(k)$ is true, for some integer $k \geq 1$. That is

$$\frac{1}{1 \cdot 2} + \frac{1}{2 \cdot 3} + \dots + \frac{1}{k(k+1)} = \frac{k}{k+1}$$

To prove $P(k+1)$ is true. That is

$$\frac{1}{1 \cdot 2} + \frac{1}{2 \cdot 3} + \dots + \frac{1}{(k+1)(k+1+1)} = \frac{k+1}{(k+1)+1} \dots\dots\dots(2)$$

Now we will consider the L.H.S of the equation (2) and will try to get the R.H.S by using equation (1) and some simple computation.

Consider LHS of (2)

$$\begin{aligned} & \frac{1}{1 \cdot 2} + \frac{1}{2 \cdot 3} + \dots + \frac{1}{(k+1)(k+2)} \\ &= \frac{1}{1 \cdot 2} + \frac{1}{2 \cdot 3} + \dots + \frac{1}{k(k+1)} + \frac{1}{(k+1)(k+2)} \\ &= \frac{k}{k+1} + \frac{1}{(k+1)(k+2)} \\ &= \frac{k(k+2)+1}{(k+1)(k+2)} \\ &= \frac{k^2+2k+1}{(k+1)(k+2)} \\ &= \frac{(k+1)^2}{(k+1)(k+2)} \\ &= \frac{k+1}{(k+2)} \\ &= \text{RHS of (2)} \end{aligned}$$

Hence $P(k+1)$ is also true and so by Mathematical induction the given equation is true for all integers $n \geq 1$.

EXERCISE:

Use mathematical induction to prove that

$$\sum_{i=1}^{n+1} i \cdot 2^i = n \cdot 2^{n+2} + 2, \quad \text{for all integers } n \geq 0$$

SOLUTION:**1. Basis Step:**

To prove the formula for $n = 0$, we need to show that

$$\sum_{i=1}^{0+1} i \cdot 2^i = 0 \cdot 2^{0+2} + 2$$

$$\text{Now, L.H.S} = \sum_{i=1}^1 i \cdot 2^i = (1)2^1 = 2$$

$$\begin{aligned} \text{R.H.S} &= 0 \cdot 2^2 + 2 = 0 + 2 = 2 \\ \text{Hence the formula is true for } n &= 0 \end{aligned}$$

2. Inductive Step:

Suppose for some integer $n=k \geq 0$

$$\sum_{i=1}^{k+1} i \cdot 2^i = k \cdot 2^{k+2} + 2 \quad \dots\dots\dots(1)$$

We must show that

$$\sum_{i=1}^{k+2} i \cdot 2^i = (k+1) \cdot 2^{k+2} + 2 \quad \dots\dots\dots(2)$$

Consider LHS of (2)

$$\begin{aligned} \sum_{i=1}^{k+2} i \cdot 2^i &= \sum_{i=1}^{k+1} i \cdot 2^i + (k+2) \cdot 2^{k+2} \\ &= (k \cdot 2^{k+2} + 2) + (k+2) \cdot 2^{k+2} \\ &= (k+k+2)2^{k+2} + 2 \\ &= (2k+2) \cdot 2^{k+2} + 2 \\ &= (k+1)2 \cdot 2^{k+2} + 2 \\ &= (k+1) \cdot 2^{k+1+2} + 2 \\ &= \text{RHS of equation (2)} \end{aligned}$$

Hence the inductive step is proved as well. Accordingly by mathematical induction the given formula is true for all integers $n \geq 0$.

EXERCISE:

Use mathematical induction to prove that

$$\left(1 - \frac{1}{2^2}\right) \cdot \left(1 - \frac{1}{3^2}\right) \cdots \left(1 - \frac{1}{n^2}\right) = \frac{n+1}{2n} \quad \text{for all integers } n \geq 2$$

SOLUTION:**1. Basis Step:**

For $n = 2$

$$\text{L.H.S} = 1 - \frac{1}{2^2} = 1 - \frac{1}{4} = \frac{3}{4}$$

$$\text{R.H.S} = \frac{2+1}{2(2)} = \frac{3}{4}$$

Hence the given formula is true for $n = 2$

2. Inductive Step:

Suppose for some integer $k \geq 2$

$$\left(1 - \frac{1}{2^2}\right) \cdot \left(1 - \frac{1}{3^2}\right) \cdots \left(1 - \frac{1}{k^2}\right) = \frac{k+1}{2k} \quad \dots\dots\dots(1)$$

We must show that

$$\left(1 - \frac{1}{2^2}\right) \cdot \left(1 - \frac{1}{3^2}\right) \cdots \left(1 - \frac{1}{(k+1)^2}\right) = \frac{(k+1)+1}{2(k+1)} \dots\dots\dots(2)$$

Consider L.H.S of (2)

$$\begin{aligned} & \left(1 - \frac{1}{2^2}\right) \cdot \left(1 - \frac{1}{3^2}\right) \cdots \left(1 - \frac{1}{(k+1)^2}\right) \\ &= \left[\left(1 - \frac{1}{2^2}\right) \cdot \left(1 - \frac{1}{3^2}\right) \cdots \left(1 - \frac{1}{k^2}\right) \right] \left(1 - \frac{1}{(k+1)^2}\right) \\ &= \left(\frac{k+1}{2k}\right) \left(1 - \frac{1}{(k+1)^2}\right) \\ &= \left(\frac{k+1}{2k}\right) \left(\frac{(k+1)^2 - 1}{(k+1)^2}\right) \\ &= \left(\frac{1}{2k}\right) \left(\frac{k^2 + 2k + 1 - 1}{(k+1)}\right) \\ &= \frac{k^2 + 2k}{2k(k+1)} = \frac{k(k+2)}{2k(k+1)} \\ &= \frac{k+1+1}{2(k+1)} = \text{RHS of (2)} \end{aligned}$$

Hence by mathematical induction the given equation is true

EXERCISE:

Prove by mathematical induction

$$\sum_{i=1}^n i(i!) = (n+1)! - 1 \quad \text{for all integers } n \geq 1$$

SOLUTION:

1. Basis step:

$$\begin{aligned} \text{For } n = 1 \\ \text{L.H.S} &= \sum_{i=1}^1 i(i!) = (1)(1!) = 1 \\ \text{R.H.S} &= (1+1)! - 1 = 2! - 1 \\ &= 2 - 1 = 1 \end{aligned}$$

Hence

$$\sum_{i=1}^1 i(i!) = (1+1)! - 1$$

which proves the basis step.

2. Inductive Step:

Suppose for any integer $k \geq 1$

$$\sum_{i=1}^k i(i!) = (k+1)! - 1 \quad \dots\dots\dots(1)$$

We need to prove that

$$\sum_{i=1}^{k+1} i(i!) = (k+1+1)! - 1 \quad \dots\dots\dots(2)$$

Consider LHS of (2)

$$\begin{aligned} \sum_{i=1}^{k+1} i(i!) &= \sum_{i=1}^k i(i!) + (k+1)(k+1)! && \text{Using (1)} \\ &= (k+1)! - 1 + (k+1)(k+1)! \\ &= (k+1)! + (k+1)(k+1)! - 1 \\ &= [1 + (k+1)](k+1)! - 1 \\ &= (k+2)(k+1)! - 1 \\ &= (k+2)! - 1 \\ &= \text{RHS of (2)} \end{aligned}$$

Hence the inductive step is also true.

Accordingly, by mathematical induction, the given formula is true for all integers $n \geq 1$.

EXERCISE:

Use mathematical induction to prove the generalization of the following DeMorgan's Law:

$$\overline{\bigcap_{j=1}^n A_j} = \bigcup_{j=1}^n \overline{A_j}$$

where A_1, A_2, \dots, A_n are subsets of a universal set U and $n \geq 2$.

SOLUTION:

Let $P(n)$ be the given propositional function

1. Basis Step:

$P(2)$ is true.

$$\begin{aligned} \text{L.H.S of } P(2) &= \overline{\bigcap_{j=1}^2 A_j} = \overline{A_1 \cap A_2} && \text{By DeMorgan's Law} \\ &= \overline{A_1} \cup \overline{A_2} \end{aligned}$$

2. Inductive Step:

$$= \bigcup_{j=1}^2 \overline{A_j} = \text{RHS of } P(2)$$

Assume that $P(k)$ is true for some integer $k \geq 2$; i.e.,

$$\overline{\bigcap_{j=1}^k A_j} = \bigcup_{j=1}^k \overline{A_j} \quad \dots\dots\dots(1)$$

where A_1, A_2, \dots, A_k are subsets of the universal set U . If A_{k+1} is another set of U , then we need to show that

$$\overline{\bigcap_{j=1}^{k+1} A_j} = \bigcup_{j=1}^{k+1} \overline{A_j} \quad \dots\dots\dots(2)$$

Consider L.H.S of (2)

$$\begin{aligned} \overline{\bigcap_{j=1}^{k+1} A_j} &= \overline{\left(\bigcap_{j=1}^k A_j\right) \cap A_{k+1}} \\ &= \overline{\left(\bigcap_{j=1}^k A_j\right)} \cup \overline{A_{k+1}} && \text{By DeMorgan's Law} \\ &= \left(\bigcup_{j=1}^k \overline{A_j}\right) \cup \overline{A_{k+1}} \\ &= \bigcup_{j=1}^{k+1} \overline{A_j} \\ &= \text{R.H.S of (2)} \end{aligned}$$

Hence by mathematical induction, the given generalization of DeMorgan's Law holds.

Lecture No.24 Mathematical induction for divisibility

MATHEMATICAL INDUCTION FOR DIVISIBILITY PROBLEMS INEQUALITY PROBLEMS

DIVISIBILITY:

Let n and d be integers and $d \neq 0$. Then n is divisible by d or d divides n written $d|n$. iff $n = d \cdot k$ for some integer k .

Alternatively, we say that

n is a multiple of d

d is a divisor of n

d is a factor of n

Thus $d|n \Leftrightarrow \exists$ an integer k such that $n = d \cdot k$

EXERCISE:

Use mathematical induction to prove that $n^3 - n$ is divisible by 3 whenever n is a positive integer.

SOLUTION:

1. Basis Step:

For $n = 1$

$$n^3 - n = 1^3 - 1 = 1 - 1 = 0$$

which is clearly divisible by 3, since $0 = 0 \cdot 3$

Therefore, the given statement is true for $n = 1$.

2. Inductive Step:

Suppose that the statement is true for $n = k$, i.e., $k^3 - k$ is divisible by 3

for all $n \in \mathbb{Z}^+$

Then

$$k^3 - k = 3 \cdot q \dots \dots \dots (1)$$

for some $q \in \mathbb{Z}$

We need to prove that $(k+1)^3 - (k+1)$ is divisible by 3.

Now

$$\begin{aligned} (k+1)^3 - (k+1) &= (k^3 + 3k^2 + 3k + 1) - (k + 1) \\ &= k^3 + 3k^2 + 2k \\ &= (k^3 - k) + 3k^2 + 2k + k \\ &= (k^3 - k) + 3k^2 + 3k \\ &= 3 \cdot q + 3 \cdot (k^2 + k) && \text{using (1)} \\ &= 3[q + k^2 + k] \end{aligned}$$

$\Rightarrow (k+1)^3 - (k+1)$ is divisible by 3.

Hence by mathematical induction $n^3 - n$ is divisible by 3, whenever n is a positive integer.

EXAMPLE:

Use mathematical induction to prove that for all integers $n \geq 1$,

$2^{2n} - 1$ is divisible by 3.

SOLUTION:

Let $P(n)$: $2^{2n} - 1$ is divisible by 3.

1. Basis Step:

$P(1)$ is true

Now $P(1)$: $2^{2(1)} - 1$ is divisible by 3.

$$\text{Since } 2^{2(1)} - 1 = 4 - 1 = 3$$

which is divisible by 3.

Hence $P(1)$ is true.

2. Inductive Step:

Suppose that $P(k)$ is true. That is $2^{2k} - 1$ is divisible by 3. Then, there exists an integer q such that

$$2^{2k} - 1 = 3 \cdot q \dots\dots\dots(1)$$

To prove $P(k+1)$ is true, that is $2^{2(k+1)} - 1$ is divisible by 3.

Now consider

$$\begin{aligned} 2^{2(k+1)} - 1 &= 2^{2k+2} - 1 \\ &= 2^{2k} 2^2 - 1 \\ &= 2^{2k} 4 - 1 \\ &= 2^{2k} (3+1) - 1 \\ &= 2^{2k} \cdot 3 + (2^{2k} - 1) \\ &= 2^{2k} \cdot 3 + 3 \cdot q \quad [\text{by using (1)}] \\ &= 3(2^{2k} + q) \end{aligned}$$

$\Rightarrow 2^{2(k+1)} - 1$ is divisible by 3.

Accordingly, by mathematical induction, $2^{2n} - 1$ is divisible by 3, for all integers $n \geq 1$.

EXERCISE:

Use mathematical induction to show that the product of any two consecutive positive integers is divisible by 2.

SOLUTION:

Let n and $n + 1$ be two consecutive integers. We need to prove that $n(n+1)$ is divisible by 2.

1. Basis Step:

For $n = 1$

$$n(n+1) = 1 \cdot (1+1) = 1 \cdot 2 = 2$$

which is clearly divisible by 2.

2. Inductive Step:

Suppose the given statement is true for $n = k$. That is $k(k+1)$ is divisible by 2, for some $k \in \mathbb{Z}^+$

Then $k(k+1) = 2 \cdot q \dots\dots\dots(1) \quad q \in \mathbb{Z}^+$

We must show that

$(k+1)(k+1+1)$ is divisible by 2.

$$\begin{aligned} \text{Consider } (k+1)(k+1+1) &= (k+1)(k+2) \\ &= (k+1)k + (k+1)2 \\ &= 2q + 2(k+1) \text{ using (1)} \\ &= 2(q+k+1) \end{aligned}$$

Hence $(k+1)(k+1+1)$ is also divisible by 2.

Accordingly, by mathematical induction, the product of any two consecutive positive integers is divisible by 2

EXERCISE:

Prove by mathematical induction $n^3 - n$ is divisible by 6, for each integer $n \geq 2$.

SOLUTION:**1.Basis Step:**For $n = 2$

$$n^3 - n = 2^3 - 2 = 8 - 2 = 6$$

which is clearly divisible by 6, since $6 = 1 \cdot 6$ Therefore, the given statement is true for $n = 2$.**2.Inductive Step:**

Suppose that the statement is true for $n = k$, i.e., $k^3 - k$ is divisible by 6, for all integers $k \geq 2$.

Then

$$k^3 - k = 6 \cdot q \dots \dots \dots (1) \text{ for some } q \in \mathbb{Z}.$$

We need to prove that

 $(k+1)^3 - (k+1)$ is divisible by 6

$$\text{Now } (k+1)^3 - (k+1) = (k^3 + 3k^2 + 3k + 1) - (k+1)$$

$$= k^3 + 3k^2 + 2k$$

$$= (k^3 - k) + (3k^2 + 2k + k)$$

$$= (k^3 - k) + 3k^2 + 3k \quad \text{Using (1)}$$

$$= 6 \cdot q + 3k(k+1) \dots \dots \dots (2)$$

Since k is an integer, so $k(k+1)$ being the product of two consecutive integers is an even number.

$$\text{Let } k(k+1) = 2r \quad r \in \mathbb{Z}$$

Now equation (2) can be rewritten as:

$$(k+1)^3 - (k+1) = 6 \cdot q + 3 \cdot 2r$$

$$= 6q + 6r$$

$$= 6(q+r) \quad q, r \in \mathbb{Z}$$

$$\Rightarrow (k+1)^3 - (k+1) \text{ is divisible by } 6.$$

Hence, by mathematical induction, $n^3 - n$ is divisible by 6, for each integer $n \geq 2$.

EXERCISE:

Prove by mathematical induction. For any integer $n \geq 1$, $x^n - y^n$ is divisible by $x - y$, where x and y are any two integers with $x \neq y$.

SOLUTION:**1.Basis Step:**For $n = 1$

$$x^n - y^n = x^1 - y^1 = x - y$$

which is clearly divisible by $x - y$. So, the statement is true for $n = 1$.**2.Inductive Step:**Suppose the statement is true for $n = k$, i.e.,

$$x^k - y^k \text{ is divisible by } x - y \dots \dots \dots (1)$$

We need to prove that $x^{k+1} - y^{k+1}$ is divisible by $x - y$

Now

$$x^{k+1} - y^{k+1} = x^k \cdot x - y^k \cdot y$$

$$= x^k \cdot x - x \cdot y^k + x \cdot y^k - y^k \cdot y \quad (\text{introducing } x \cdot y^k)$$

$$= (x^k - y^k) \cdot x + y^k \cdot (x - y)$$

The first term on R.H.S. $(x^k - y^k)$ is divisible by $x - y$ by inductive hypothesis (1).

The second term contains a factor $(x - y)$ so is also divisible by $x - y$.

Thus $x^{k+1} - y^{k+1}$ is divisible by $x - y$. Hence, by mathematical induction $x^n - y^n$ is divisible by $x - y$ for any integer $n \geq 1$.

PROVING AN INEQUALITY:

Use mathematical induction to prove that for all integers $n \geq 3$.

$$2n + 1 < 2^n$$

SOLUTION:

1. Basis Step:

For $n = 3$

$$\text{L.H.S} = 2(3) + 1 = 6 + 1 = 7$$

$$\text{R.H.S} = 2^3 = 8$$

Since $7 < 8$, so the statement is true for $n = 3$.

2. Inductive Step:

Suppose the statement is true for $n = k$, i.e.,

$$2k + 1 < 2^k \dots \dots \dots (1) \quad k \geq 3$$

We need to show that the statement is true for $n = k+1$,

i.e.;

$$2(k+1) + 1 < 2^{k+1} \dots \dots \dots (2)$$

Consider L.H.S of (2)

$$= 2(k+1) + 1$$

$$= 2k + 2 + 1$$

$$= (2k + 1) + 2$$

$$< 2^k + 2$$

using (1)

$$< 2^k + 2^k$$

(since $2 < 2^k$ for $k \geq 3$)

$$< 2 \cdot 2^k = 2^{k+1}$$

Thus $2(k+1)+1 < 2^{k+1}$ (proved)

EXERCISE:

Show by mathematical induction

$$1 + n x \leq (1+x)^n$$

for all real numbers $x > -1$ and integers $n \geq 2$

SOLUTION:

1. Basis Step:

For $n = 2$

$$\text{L.H.S} = 1 + (2) x = 1 + 2x$$

$$\text{RHS} = (1 + x)^2 = 1 + 2x + x^2 > 1 + 2x \quad (x^2 > 0)$$

\Rightarrow statement is true for $n = 2$.

2. Inductive Step:

Suppose the statement is true for $n = k$.

That is, for $k \geq 2$, $1 + k x \leq (1 + x)^k \dots \dots \dots (1)$

We want to show that the statement is also true for $n = k + 1$ i.e.,

$$1 + (k + 1)x \leq (1 + x)^{k+1}$$

Since $x > -1$, therefore $1 + x > 0$.

Multiplying both sides of (1) by $(1+x)$ we get

$$\begin{aligned}(1+x)(1+x)^k &\geq (1+x)(1+kx) \\ &= 1+kx+x+kx^2 \\ &= 1+(k+1)x+kx^2\end{aligned}$$

but

$$\text{so } \left[\begin{array}{l} x > -1, \quad \text{so } x^2 \geq 0 \\ \& \quad k \geq 2, \quad \text{so } kx^2 \geq 0 \end{array} \right.$$

$$(1+x)(1+x)^k \geq 1+(k+1)x$$

Thus $1+(k+1)x \leq (1+x)^{k+1}$. Hence by mathematical induction, the inequality is true.

PROVING A PROPERTY OF A SEQUENCE:

Define a sequence a_1, a_2, a_3, \dots as follows:

$$a_1 = 2$$

$$a_k = 5a_{k-1} \quad \text{for all integers } k \geq 2 \quad \dots\dots\dots(1)$$

Use mathematical induction to show that the terms of the sequence satisfy the formula.

$$a_n = 2 \cdot 5^{n-1} \quad \text{for all integers } n \geq 1$$

SOLUTION:

1.Basis Step:

For $n = 1$, the formula gives

$$a_1 = 2 \cdot 5^{1-1} = 2 \cdot 5^0 = 2 \cdot 1 = 2$$

which confirms the definition of the sequence. Hence, the formula is true for $n = 1$.

2.Inductive Step:

Suppose, that the formula is true for $n = k$, i.e.,

$$a_k = 2 \cdot 5^{k-1} \quad \text{for some integer } k \geq 1$$

We show that the statement is also true for $n = k + 1$. i.e.,

$$a_{k+1} = 2 \cdot 5^{k+1-1} = 2 \cdot 5^k$$

Now

$$\begin{aligned}a_{k+1} &= 5 \cdot a_{k+1-1} \quad [\text{by definition of } a_1, a_2, a_3 \dots \text{ or by putting } k+1 \text{ in (1)}] \\ &= 5 \cdot a_k \\ &= 5 \cdot (2 \cdot 5^{k-1}) \quad \text{by inductive hypothesis} \\ &= 2 \cdot (5 \cdot 5^{k-1}) \\ &= 2 \cdot 5^{k+1-1} \\ &= 2 \cdot 5^k\end{aligned}$$

which was required.

EXERCISE:

A sequence d_1, d_2, d_3, \dots is defined by letting $d_1 = 2$ and $d_k = \frac{d_{k-1}}{k}$

for all integers $k \geq 2$. Show that $d_n = \frac{2}{n!}$ for all integers $n \geq 1$, using mathematical induction.

SOLUTION:

1.Basis Step:

For $n = 1$, the formula $d_n = \frac{2}{n!}$; $n \geq 1$ gives

$$d_1 = \frac{2}{1!} = \frac{2}{1} = 2$$

which agrees with the definition of the sequence.

2. Inductive Step:

Suppose, the formula is true for $n=k$. i.e.,

$$d_k = \frac{2}{k!} \quad \text{for some integer } k \geq 1 \dots \dots \dots (1)$$

We must show that

$$d_{k+1} = \frac{2}{(k+1)!}$$

Now, by the definition of the sequence.

$$\begin{aligned} d_{k+1} &= \frac{d_{(k+1)-1}}{(k+1)} = \frac{1}{(k+1)} d_k & \text{using } d_k &= \frac{d_{k-1}}{k} \\ &= \frac{1}{(k+1)} \frac{2}{k!} & \text{using (1)} & \\ &= \frac{2}{(k+1)!} \end{aligned}$$

Hence the formula is also true for $n = k + 1$. Accordingly, the given formula defines all the terms of the sequence recursively.

EXERCISE:

Prove by mathematical induction that

$$1 + \frac{1}{4} + \frac{1}{9} + \dots + \frac{1}{n^2} < 2 - \frac{1}{n}$$

Whenever n is a positive integer greater than 1.

SOLUTION:

1. Basis Step: for $n = 2$

$$\text{L.H.S} = 1 + \frac{1}{4} = \frac{5}{4} = 1.25$$

$$\text{R.H.S} = 2 - \frac{1}{2} = \frac{3}{2} = 1.5$$

Clearly $\text{LHS} < \text{RHS}$

Hence the statement is true for $n = 2$.

2. Inductive Step:

Suppose that the statement is true for some integers $k > 1$, i.e.;

$$1 + \frac{1}{4} + \frac{1}{9} + \dots + \frac{1}{k^2} < 2 - \frac{1}{k} \quad (1)$$

We need to show that the statement is true for $n = k + 1$. That is

$$1 + \frac{1}{4} + \frac{1}{9} + \cdots + \frac{1}{(k+1)^2} < 2 - \frac{1}{k+1} \quad (2)$$

Consider the L.H. S of (2)

$$\begin{aligned} 1 + \frac{1}{4} + \frac{1}{9} + \cdots + \frac{1}{(k+1)^2} &= 1 + \frac{1}{4} + \frac{1}{9} + \cdots + \frac{1}{k^2} + \frac{1}{(k+1)^2} \\ &< \left(2 - \frac{1}{k}\right) + \frac{1}{(k+1)^2} \\ &= 2 - \left(\frac{1}{k} - \frac{1}{(k+1)^2}\right) \end{aligned}$$

We need to prove that

$$\begin{aligned} 2 - \left(\frac{1}{k} - \frac{1}{(k+1)^2}\right) &\leq 2 - \frac{1}{k+1} \\ \text{or } -\left(\frac{1}{k} - \frac{1}{(k+1)^2}\right) &\leq -\frac{1}{k+1} \\ \text{or } \frac{1}{k} - \frac{1}{(k+1)^2} &\geq \frac{1}{k+1} \\ \text{or } \frac{1}{k} - \frac{1}{k+1} &\geq \frac{1}{(k+1)^2} \\ \text{Now } \frac{1}{k} - \frac{1}{k+1} &= \frac{k+1-k}{k(k+1)} \\ &= \frac{1}{k(k+1)} > \frac{1}{(k+1)^2} \end{aligned}$$

Lecture No.25 Methods of proof

METHODS OF PROOF

DIRECT PROOF

DISPROOF BY

COUNTER EXAMPLE

INTRODUCTION:

To understand written mathematics, one must understand what makes up a correct mathematical argument, that is, a proof. This requires an understanding of the techniques used to build proofs. The methods we will study for building proofs are also used throughout computer science, such as the rules computers used to reason, the techniques used to verify that programs are correct, etc.

Many theorems in mathematics are implications, $p \rightarrow q$. The techniques of proving implications give rise to different methods of proofs.

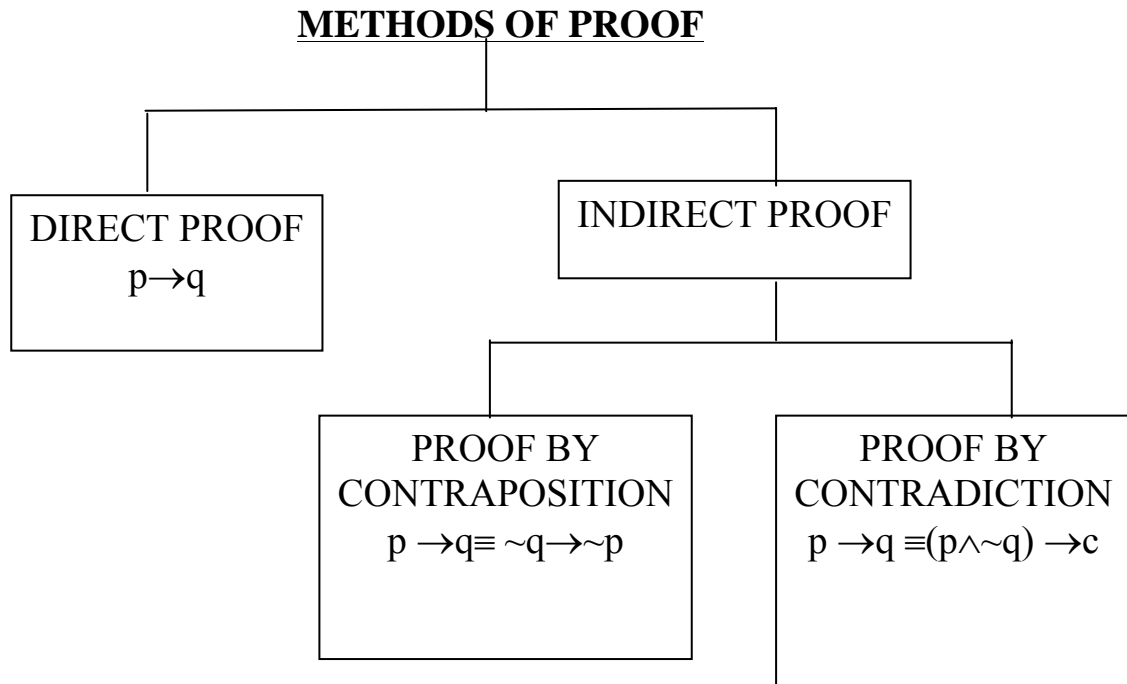

DIRECT PROOF:

The implication $p \rightarrow q$ can be proved by showing that if p is true, the q must also be true. This shows that the combination p true and q false never occurs. A proof of this kind is called a direct proof.

p	q	$p \rightarrow q$
T	T	T
T	F	F
F	T	T
F	F	T

SOME BASICS:

1. An integer n is even if, and only if, $n = 2k$ for some integer k .
2. An integer n is odd if, and only if, $n = 2k + 1$ for some integer k .
3. An integer n is prime if, and only if, $n > 1$ and for all positive integers r and s , if $n = r \cdot s$, then $r = 1$ or $s = 1$.
4. An integer $n > 1$ is composite if, and only if, $n = r \cdot s$ for some positive integers r and s with $r \neq 1$ and $s \neq 1$.
5. A real number r is rational if, and only if, $r = \frac{a}{b}$ for some integers a and b with $b \neq 0$.
6. If n and d are integers and $d \neq 0$, then d divides n , written $d|n$ if, and only if, $n = d \cdot k$ for some integers k .
7. An integer n is called a perfect square if, and only if, $n = k^2$ for some integer k .

EXERCISE:

Prove that the sum of two odd integers is even.

SOLUTION:

Let m and n be two odd integers. Then by definition of odd numbers

$$m = 2k + 1 \quad \text{for some } k \in \mathbb{Z}$$

$$n = 2l + 1 \quad \text{for some } l \in \mathbb{Z}$$

$$\begin{aligned} \text{Now } m + n &= (2k + 1) + (2l + 1) \\ &= 2k + 2l + 2 \\ &= 2(k + l + 1) \\ &= 2r \quad \text{where } r = (k + l + 1) \in \mathbb{Z} \end{aligned}$$

Hence $m + n$ is even.

EXERCISE:

Prove that if n is any even integer, then $(-1)^n = 1$

SOLUTION:

Suppose n is an even integer. Then $n = 2k$ for some integer k .

Now

$$\begin{aligned} (-1)^n &= (-1)^{2k} \\ &= [(-1)^2]^k \\ &= (1)^k \\ &= 1 \quad \text{(proved)} \end{aligned}$$

EXERCISE:

Prove that the product of an even integer and an odd integer is even.

SOLUTION:

Suppose m is an even integer and n is an odd integer. Then

$$\begin{array}{ll} m = 2k & \text{for some integer } k \\ \text{and } n = 2l + 1 & \text{for some integer } l \end{array}$$

Now

$$\begin{aligned} m \cdot n &= 2k \cdot (2l + 1) \\ &= 2 \cdot k (2l + 1) \\ &= 2 \cdot r \quad \text{where } r = k(2l + 1) \text{ is an integer} \end{aligned}$$

Hence $m \cdot n$ is even. (Proved)

EXERCISE:

Prove that the square of an even integer is even.

SOLUTION:

Suppose n is an even integer. Then $n = 2k$

Now

$$\begin{aligned} \text{square of } n &= n^2 = (2 \cdot k)^2 \\ &= 4k^2 \\ &= 2 \cdot (2k^2) \\ &= 2 \cdot p \quad \text{where } p = 2k^2 \in \mathbb{Z} \end{aligned}$$

Hence, n^2 is even. (proved)

EXERCISE:

Prove that if n is an odd integer, then $n^3 + n$ is even.

SOLUTION:

Let n be an odd integer, then $n = 2k + 1$ for some $k \in \mathbb{Z}$

$$\begin{aligned} \text{Now } n^3 + n &= n(n^2 + 1) \\ &= (2k + 1)((2k + 1)^2 + 1) \\ &= (2k + 1)(4k^2 + 4k + 1 + 1) \\ &= (2k + 1)(4k^2 + 4k + 2) \\ &= (2k + 1) \cdot 2 \cdot (2k^2 + 2k + 1) \\ &= 2 \cdot (2k + 1)(2k^2 + 2k + 1) \quad k \in \mathbb{Z} \\ &= \text{an even integer} \end{aligned}$$

EXERCISE:

Prove that, if the sum of any two integers is even, then so is their difference.

SOLUTION:

Suppose m and n are integers so that $m + n$ is even. Then by definition of even numbers

$$\begin{array}{ll} m + n = 2k & \text{for some integer } k \\ \Rightarrow m = 2k - n & \dots\dots\dots(1) \end{array}$$

$$\begin{aligned} \text{Now } m - n &= (2k - n) - n \quad \text{using (1)} \\ &= 2k - 2n \\ &= 2(k - n) = 2r \quad \text{where } r = k - n \text{ is an integer} \end{aligned}$$

Hence $m - n$ is even.

EXERCISE:

Prove that the sum of any two rational numbers is rational.

SOLUTION:

Suppose r and s are rational numbers.

Then by definition of rational

$$r = \frac{a}{b} \quad \text{and} \quad s = \frac{c}{d}$$

for some integers a, b, c, d with $b \neq 0$ and $d \neq 0$

Now

$$\begin{aligned} r + s &= \frac{a}{b} + \frac{c}{d} \\ &= \frac{ad + bc}{bd} \\ &= \frac{p}{q} \text{ where } p = ad + bc \in \mathbb{Z} \text{ and } q = bd \in \mathbb{Z} \\ &= \frac{p}{q} \text{ and } q \neq 0 \end{aligned}$$

Hence $r + s$ is rational. q

EXERCISE:

Given any two distinct rational numbers r and s with $r < s$. Prove that there is a rational number x such that $r < x < s$.

SOLUTION:

Given two distinct rational numbers r and s such that

$$r < s \quad \dots\dots\dots(1)$$

Adding r to both sides of (1), we get

$$\begin{aligned} r + r &< r + s \\ 2r &< r + s \end{aligned}$$

\Rightarrow

$$r < \frac{r + s}{2} \quad \dots\dots\dots(2)$$

Next adding s to both sides of (1), we get

$$r + s < s + s$$

\Rightarrow

$$r + s < 2s$$

\Rightarrow

$$\frac{r + s}{2} < s \quad \dots\dots\dots(3)$$

Combining (2) and (3), we may write

$$r < \frac{r + s}{2} < s \quad \dots\dots\dots(4)$$

Since the sum of two rationals is rational, therefore $r + s$ is rational. Also the quotient of a rational by a non-zero rational, is rational, therefore $\frac{r + s}{2}$ is rational and by (4) it lies between r & s .

Hence, we have found a rational number such that $r < x < s$. (proved)

EXERCISE:

Prove that for all integers a, b and c , if $a|b$ and $b|c$ then $a|c$.

PROOF:

Suppose $a|b$ and $b|c$ where $a, b, c \in \mathbb{Z}$. Then by definition of divisibility $b = a \cdot r$ and $c = b \cdot s$ for some integers r and s .

Now

$$\begin{aligned} c &= b \cdot s \\ &= (a \cdot r) \cdot s && \text{(substituting value of } b) \\ &= a \cdot (r \cdot s) && \text{(associative law)} \end{aligned}$$

$= a \cdot k$ where $k = r \cdot s \in \mathbb{Z}$
 $\Rightarrow a|c$ by definition of divisibility

EXERCISE:

Prove that for all integers a , b and c if $a|b$ and $a|c$ then $a|(b+c)$

PROOF:

Suppose $a|b$ and $a|c$ where $a, b, c \in \mathbb{Z}$
 By definition of divides
 $b = a \cdot r$ and $c = a \cdot s$ for some $r, s \in \mathbb{Z}$

Now

$$\begin{aligned} b + c &= a \cdot r + a \cdot s && \text{(substituting values)} \\ &= a \cdot (r+s) && \text{(by distributive law)} \\ &= a \cdot k && \text{where } k = (r + s) \in \mathbb{Z} \end{aligned}$$

Hence $a|(b + c)$ by definition of divides.

EXERCISE:

Prove that the sum of any three consecutive integers is divisible by 3.

PROOF:

Let n , $n + 1$ and $n + 2$ be three consecutive integers.

Now

$$\begin{aligned} n + (n + 1) + (n + 2) &= 3n + 3 \\ &= 3(n + 1) \\ &= 3 \cdot k \quad \text{where } k = (n+1) \in \mathbb{Z} \end{aligned}$$

Hence, the sum of three consecutive integers is divisible by 3.

EXERCISE:

Prove the statement:

There is an integer $n > 5$ such that $2^n - 1$ is prime

PROOF:

Here we are asked to show a single integer for which $2^n - 1$ is prime. First of all we will check the integers from 1 and check whether the answer is prime or not by putting these values in $2^n - 1$. when we got the answer is prime then we will stop our process of checking the integers and we note that,

Let $n = 7$, then

$$2^n - 1 = 2^7 - 1 = 128 - 1 = 127$$

and we know that 127 is prime.

EXERCISE:

Prove the statement: There are real numbers a and b such that

$$\sqrt{a+b} = \sqrt{a} + \sqrt{b}$$

PROOF:

$$\text{Let } \sqrt{a+b} = \sqrt{a} + \sqrt{b}$$

Squaring, we get $a + b = a + b + 2\sqrt{a}\sqrt{b}$

$$\Rightarrow 0 = 2\sqrt{a}\sqrt{b} \quad \text{canceling } a+b$$

$$\Rightarrow 0 = \sqrt{ab}$$

$$\Rightarrow 0 = ab \quad \text{squaring}$$

$$\Rightarrow \text{either } a = 0 \text{ or } b = 0$$

It means that if we want to find out the integers which satisfy the given condition then one of them must be zero.

Hence if we let $a = 0$ and $b = 3$ then

$$R.H.S = \sqrt{a+b} = \sqrt{0+3}$$

$$R.H.S = \sqrt{3}$$

Now $L.H.S = \sqrt{a} + \sqrt{b}$ by putting the values of a and b we get

$$= \sqrt{0} + \sqrt{3}$$

$$L.H.S = \sqrt{3}$$

From above it quite clear that the given condition is satisfied if we take $a=0$ and $b=3$.

PROOF BY COUNTER EXAMPLE:

Disprove the statement by giving a counter example.

For all real numbers a and b , if $a < b$ then $a^2 < b^2$.

SOLUTION:

Suppose $a = -5$ and $b = -2$

then clearly $-5 < -2$

But $a^2 = (-5)^2 = 25$ and $b^2 = (-2)^2 = 4$

But $25 > 4$

This disproves the given statement.

EXERCISE:

Prove or give counter example to disprove the statement.

For all integers n , $n^2 - n + 11$ is a prime number.

SOLUTION:

The statement is not true

For $n = 11$

$$\begin{aligned} \text{we have, } n^2 - n + 11 &= (11)^2 - 11 + 11 \\ &= (11)^2 \\ &= (11)(11) \\ &= 121 \end{aligned}$$

which is obviously not a prime number.

EXERCISE:

Prove or disprove that the product of any two irrational numbers is an irrational number.

SOLUTION:

We know that $\sqrt{2}$ is an irrational number. Now

$$(\sqrt{2})(\sqrt{2}) = (\sqrt{2})^2 = 2 = \frac{2}{1}$$

which is a rational number. Hence the statement is disproved.

EXERCISE:

Find a counter example to the proposition:

For every prime number n , $n + 2$ is prime.

SOLUTION:

Let the prime number n be 7 then
 $n + 2 = 7 + 2 = 9$
which is not prime.

Lecture No.26 Proof by contradiction

PROOF BY CONTRADICTION:

A proof by contradiction is based on the fact that either a statement is true or it is false but not both. Hence the supposition, that the statement to be proved is false, leads logically to a contradiction, impossibility or absurdity, then the supposition must be false.

Accordingly, the given statement must be true.

This method of proof is also known as reductio ad absurdum because it relies on reducing a given assumption to an absurdity.

Many theorems in mathematics are conditional statements ($p \rightarrow q$). Now the negation of the implication $p \rightarrow q$ is

$$\begin{aligned} \sim(p \rightarrow q) &\equiv \sim(\sim p \vee q) \\ &\equiv \sim(\sim p) \wedge (\sim q) && \text{DeMorgan's Law} \\ &\equiv p \wedge \sim q \end{aligned}$$

Clearly if the implication is true, then its negation must be false, i.e., leads to a contradiction.

Hence $p \rightarrow q \equiv (p \wedge \sim q) \rightarrow c$

where c is a contradiction.

Thus to prove an implication $p \rightarrow q$ by contradiction method we suppose that the condition p and the negation of the conclusion q , i.e., $(p \wedge \sim q)$ is true and ultimately arrive at a contradiction.

The method of proof by contradiction, may be summarized as follows:

1. Suppose the statement to be proved is false.
2. Show that this supposition leads logically to a contradiction.
3. Conclude that the statement to be proved is true.

THEOREM:

There is no greatest integer.

PROOF:

Suppose there is a greatest integer N . Then $n \leq N$ for every integer n .

Let $M = N + 1$

Now M is an integer since it is a sum of integers.

Also $M > N$ since $M = N + 1$

Thus M is an integer that is greater than the greatest integer, which is a contradiction.

Hence our supposition is not true and so there is no greatest integer.

EXERCISE:

Give a proof by contradiction for the statement:

“If n^2 is an even integer then n is an even integer.”

PROOF:

Suppose n^2 is an even integer and n is not even, so that n is odd.

Hence $n = 2k + 1$ for some integer k .

$$\begin{aligned} \text{Now } n^2 &= (2k + 1)^2 \\ &= 4k^2 + 4k + 1 \\ &= 2 \cdot (2k^2 + 2k) + 1 \end{aligned}$$

$$= 2r + 1 \quad \text{where } r = (2k^2 + 2k) \in \mathbb{Z}$$

This shows that n^2 is odd, which is a contradiction to our supposition that n^2 is even. Hence the given statement is true.

EXERCISE:

Prove that if n is an integer and $n^3 + 5$ is odd, then n is even using contradiction method.

SOLUTION:

Suppose that $n^3 + 5$ is odd and n is not even (odd). Since n is odd and the product of two odd numbers is odd, it follows that n^2 is odd and $n^3 = n^2 \cdot n$ is odd. Further, since the difference of two odd number is even, it follows that

$$5 = (n^3 + 5) - n^3$$

is even. But this is a contradiction. Therefore, the supposition that $n^3 + 5$ and n are both odd is wrong and so the given statement is true.

EXERCISE:

Prove by contradiction method, the statement: If n and m are odd integers, then $n + m$ is an even integer.

SOLUTION:

Suppose n and m are odd and $n + m$ is not even (odd i.e by taking contradiction).

$$\begin{array}{ll} \text{Now} & n = 2p + 1 & \text{for some integer } p \\ \text{and} & m = 2q + 1 & \text{for some integer } q \end{array}$$

$$\begin{aligned} \text{Hence} \quad n + m &= (2p + 1) + (2q + 1) \\ &= 2p + 2q + 2 = 2 \cdot (p + q + 1) \end{aligned}$$

which is even, contradicting the assumption that $n + m$ is odd.

THEOREM:

The sum of any rational number and any irrational number is irrational.

PROOF:

We suppose that the negation of the statement is true. That is, we suppose that there is a rational number r and an irrational number s such that $r + s$ is rational. By definition of ration

$$r = \frac{a}{b}$$

.....(1)

and

.....(2)

$$r + s = \frac{c}{d}$$

for some integers a, b, c and d with $b \neq 0$ and $d \neq 0$.

Using (1) in (2), we get

$$\begin{aligned} \frac{a}{b} + s &= \frac{c}{d} \\ \Rightarrow s &= \frac{c}{d} - \frac{a}{b} \\ s &= \frac{bc - ad}{bd} \quad (bd \neq 0) \end{aligned}$$

Now $bc - ad$ and bd are both integers, since products and difference of integers are integers. Hence s is a quotient of two integers $bc - ad$ and bd with $bd \neq 0$. So by definition of rational, s is rational.

This contradicts the supposition that s is irrational. Hence the supposition is false and the theorem is true.

EXERCISE:

Prove that $\sqrt{2}$ is irrational.

PROOF:

Suppose $\sqrt{2}$ is rational. Then there are integers m and n with no common factors so that

$$\sqrt{2} = \frac{m}{n}$$

Squaring both sides gives

$$2 = \frac{m^2}{n^2}$$

Or $m^2 = 2n^2$ (1)

This implies that m^2 is even (by definition of even). It follows that m is even. Hence

$$m = 2k \quad \text{for some integer } k \quad (2)$$

Substituting (2) in (1), we get

$$\begin{aligned} (2k)^2 &= 2n^2 \\ \Rightarrow 4k^2 &= 2n^2 \\ \Rightarrow n^2 &= 2k^2 \end{aligned}$$

This implies that n^2 is even, and so n is even. But we also know that m is even. Hence both m and n have a common factor 2. But this contradicts the supposition that m and n have no common factors. Hence our supposition is false and so the theorem is true.

Substituting (2) in (1), we get

$$\begin{aligned} (2k)^2 &= 2n^2 \\ \Rightarrow 4k^2 &= 2n^2 \\ \Rightarrow n^2 &= 2k^2 \end{aligned}$$

This implies that n^2 is even, and so n is even. But we also know that m is even. Hence both m and n have a common factor 2. But this contradicts the supposition that m and n have no common factors. Hence our supposition is false and so the theorem is true.

EXERCISE:

Prove by contradiction that $6 - 7\sqrt{2}$ is irrational.

PROOF:

Suppose $6 - 7\sqrt{2}$ is rational.
Then by definition of rational,

$$6 - 7\sqrt{2} = \frac{a}{b}$$

for some integers a and b with $b \neq 0$.
Now consider,

$$\begin{aligned} 7\sqrt{2} &= 6 - \frac{a}{b} \\ \Rightarrow 7\sqrt{2} &= \frac{6b - a}{b} \\ \Rightarrow \sqrt{2} &= \frac{6b - a}{7b} \end{aligned}$$

Since a and b are integers, so are $6b - a$ and $7b$ and $7b \neq 0$;
hence $\sqrt{2}$ is a quotient of the two integers $6b - a$ and $7b$ with $7b \neq 0$.
Accordingly, $\sqrt{2}$ is rational (by definition of rational).
This contradicts the fact because $\sqrt{2}$ is irrational.
Hence our supposition is false and so $6 - 7\sqrt{2}$ is irrational.

EXERCISE:

Prove that $\sqrt{2} + \sqrt{3}$ is irrational.

SOLUTION:

Suppose $\sqrt{2} + \sqrt{3}$ is rational. Then, by definition of rational, there exists integers a and b with $b \neq 0$ such that

$$\sqrt{2} + \sqrt{3} = \frac{a}{b}$$

Squaring both sides, we get

$$2 + 3 + 2\sqrt{2}\sqrt{3} = \frac{a^2}{b^2}$$

$$\Rightarrow 2\sqrt{2 \times 3} = \frac{a^2}{b^2} - 5$$

$$\Rightarrow 2\sqrt{6} = \frac{a^2 - 5b^2}{b^2}$$

$$\Rightarrow \sqrt{6} = \frac{a^2 - 5b^2}{2b^2}$$

Since a and b are integers, so are therefore $a^2 - 5b^2$ and $2b^2$ with $2b^2 \neq 0$. Hence $\sqrt{6}$ is the quotient of two integers $a^2 - 5b^2$ and $2b^2$ with $2b^2 \neq 0$. Accordingly, $\sqrt{6}$ is rational. But this is a contradiction, since $\sqrt{6}$ is not rational. Hence our supposition is false and so $\sqrt{2} + \sqrt{3}$ is irrational.

REMARK:

The sum of two irrational numbers need not be irrational in general for

$$(6 - 7\sqrt{2}) + (6 + 7\sqrt{2}) = 6 + 6 = 12$$

which is rational.

EXERCISE:

Prove that for any integer a and any prime number p , if $p|a$, then $p \nmid (a + 1)$.

PROOF:

Suppose there exists an integer a and a prime number p such that $p|a$ and $p|(a+1)$. Then by definition of divisibility there exist integer r and s so that

$$a = p \cdot r \quad \text{and} \quad a + 1 = p \cdot s$$

It follows that

$$\begin{aligned} 1 &= (a + 1) - a \\ &= p \cdot s - p \cdot r \\ &= p \cdot (s - r) \quad \text{where } s - r \in \mathbb{Z} \end{aligned}$$

This implies $p|1$.

But the only integer divisors of 1 are 1 and -1 and since p is prime $p > 1$. This is a contradiction.

Hence the supposition is false, and the given statement is true.

THEOREM:

The set of prime numbers is infinite.

PROOF:

Suppose the set of prime numbers is finite.

Then, all the prime numbers can be listed, say, in ascending order:

$$p_1 = 2, p_2 = 3, p_3 = 5, p_4 = 7, \dots, p_n$$

Consider the integer

$$N = p_1 \cdot p_2 \cdot p_3 \cdot \dots \cdot p_n + 1$$

Then $N > 1$. Since any integer greater than 1 is divisible by some prime number p , therefore $p \mid N$.

Also since p is prime, p must equal one of the prime numbers

$$p_1, p_2, p_3, \dots, p_n.$$

Thus

$$p \mid (p_1, p_2, p_3, \dots, p_n)$$

But then

$$p \not\mid (p_1, p_2, p_3, \dots, p_n + 1)$$

$$\text{So } p \not\mid N$$

Thus $p \mid N$ and $p \not\mid N$, which is a contradiction.

Hence the supposition is false and the theorem is true.

PROOF BY CONTRAPOSITION:

A proof by contraposition is based on the logical equivalence between a statement and its contrapositive. Therefore, the implication $p \rightarrow q$ can be proved by showing that its contrapositive $\sim q \rightarrow \sim p$ is true. The contrapositive is usually proved directly.

The method of proof by contrapositive may be summarized as:

1. Express the statement in the form if p then q .
2. Rewrite this statement in the contrapositive form
if not q then not p .
3. Prove the contrapositive by a direct proof.

EXERCISE:

Prove that for all integers n , if n^2 is even then n is even.

PROOF:

The contrapositive of the given statement is:

“if n is not even (odd) then n^2 is not even (odd)”

We prove this contrapositive statement directly.

Suppose n is odd. Then $n = 2k + 1$ for some $k \in \mathbb{Z}$

$$\begin{aligned} \text{Now } n^2 &= (2k+1)^2 = 4k^2 + 4k + 1 \\ &= 2 \cdot (2k^2 + 2k) + 1 \\ &= 2 \cdot r + 1 \quad \text{where } r = 2k^2 + 2k \in \mathbb{Z} \end{aligned}$$

Hence n^2 is odd. Thus the contrapositive statement is true and so the given statement is true.

EXERCISE:

Prove that if $3n + 2$ is odd, then n is odd.

PROOF:

The contrapositive of the given conditional statement is

“ if n is even then $3n + 2$ is even”

Suppose n is even, then

$$n = 2k \quad \text{for some } k \in \mathbb{Z}$$

$$\text{Now } 3n + 2 = 3(2k) + 2$$

$$= 2 \cdot (3k + 1)$$

$$= 2 \cdot r \quad \text{where } r = (3k + 1) \in \mathbb{Z}$$

Hence $3n + 2$ is even. We conclude that the given statement is true since its contrapositive is true.

EXERCISE:

Prove that if n is an integer and $n^3 + 5$ is odd, then n is even.

PROOF:

Suppose n is an odd integer. Since, a product of two odd integers is odd, therefore $n^2 = n \cdot n$ is odd; and $n^3 = n^2 \cdot n$ is odd.

Since a sum of two odd integers is even therefore $n^3 + 5$ is even.

Thus we have prove that if n is odd then $n^3 + 5$ is even.

Since this is the contrapositive of the given conditional statement, so the given statement is true.

EXERCISE:

Prove that if n^2 is not divisible by 25, then n is not divisible by 5.

SOLUTION:

The contra positive statement is:

“if n is divisible by 5, then n^2 is divisible by 25”

Suppose n is divisible by 5. Then by definition of divisibility

$$n = 5 \cdot k \quad \text{for some integer } k$$

Squaring both sides

$$n^2 = 25 \cdot k^2 \quad \text{where } k^2 \in \mathbb{Z}$$

$$n^2 \text{ is divisible by } 25$$

EXERCISE:

Prove that if $|x| > 1$ then $x > 1$ or $x < -1$ for all $x \in \mathbb{R}$.

PROOF:

The contrapositive statement is:

if $x \leq 1$ and $x \geq -1$ then $|x| \leq 1$ for $x \in \mathbb{R}$.

Suppose that $x \leq 1$ and $x \geq -1$

$$\Rightarrow x \leq 1 \quad \text{and } x \geq -1$$

$$\Rightarrow -1 \leq x \leq 1$$

and so

$$|x| \leq 1$$

Equivalently $|x| > 1$

EXERCISE:

Prove the statement by contraposition:

For all integers m and n, if $m + n$ is even then m and n are both even or m and n are both odd.

PROOF:

The contrapositive statement is:

“For all integers m and n , if m and n are not both even and m and n are not both odd, then $m + n$ is not even.

Or more simply,

“For all integers m and n , if one of m and n is even and the other is odd, then $m + n$ is odd”

Suppose m is even and n is odd. Then

$$\begin{aligned} m &= 2p && \text{for some integer } p \\ \text{and } n &= 2q + 1 && \text{for some integer } q \\ \text{Now } m + n &= (2p) + (2q + 1) \\ &= 2 \cdot (p+q) + 1 \\ &= 2 \cdot r + 1 && \text{where } r = p+q \text{ is an integer} \end{aligned}$$

Hence $m + n$ is odd.

Similarly, taking m as odd and n even, we again arrive at the result that $m + n$ is odd.

Thus, the contrapositive statement is true. Since an implication is logically equivalent to its contrapositive so the given implication is true.

Lecture No.27 Algorithm

PRE- AND POST-CONDITIONS OF AN ALGORITHM

LOOP INVARIANTS

LOOP INVARIANT THEOREM

ALGORITHM:

The word "algorithm" refers to a step-by-step method for performing some action. A computer program is, similarly, a set of instructions that are executed step-by-step for performing some specific task. Algorithm, however, is a more general term in that the term program refers to a particular programming language.

INFORMATION ABOUT ALGORITHM:

The following information is generally included when describing algorithms formally:

1. The name of the algorithm, together with a list of input and output variables.
2. A brief description of how the algorithm works.
3. The input variable names, labeled by data type.
4. The statements that make the body of the algorithm, with explanatory comments.
5. The output variable names, labeled by data type.
6. An end statement.

THE DIVISION ALGORITHM:

THEOREM (Quotient-Remainder Theorem):

Given any integer n and a positive integer d , there exist unique integers q and r such that $n = d \cdot q + r$ and $0 \leq r < d$.

Example:

- | | | |
|---------------------|----------------------------|------------------------|
| a) $n = 54, d = 4$ | $54 = 4 \cdot 13 + 2;$ | hence $q = 13, r = 2$ |
| b) $n = -54, d = 4$ | $-54 = 4 \cdot (-14) + 2;$ | hence $q = -14, r = 2$ |
| c) $n = 54, d = 70$ | $54 = 70 \cdot 0 + 54;$ | hence $q = 0, r = 54$ |

ALGORITHM (DIVISION)

{Given a nonnegative integer a and a positive integer d , the aim of the algorithm is to find integers q and r that satisfy the conditions $a = d \cdot q + r$ and $0 \leq r < d$.

This is done by subtracting d repeatedly from a until the result is less than d but is still nonnegative.

The total number of d 's that are subtracted is the quotient q . The quantity $a - d \cdot q$ equals the remainder r .}

Input: a {a nonnegative integer}, d {a positive integer}

Algorithm body: $r := a, q := 0$

{Repeatedly subtract d from r until a number less than d is obtained. Add 1 to d each time d is subtracted.}

while ($r \geq d$)

$r := r - d$ $q := q + 1$

end while

Output: q, r

end Algorithm (Division)

TRACING THE DIVISION ALGORITHM:**Example:**

Trace the action of the Division Algorithm on the input variables $a = 54$ and $d = 11$

Solution

		Iteration				
		0	1	2	3	4
Variable	a	54				
	d	11				
	r	54	43	32	21	10
	q	0	1	2	3	4

PREDICATE:

Consider the sentence

“Aslam is a student at the Virtual University.”

let P stand for the words

“is a student at the Virtual University”

and let Q stand for the words

“is a student at.”

Then both P and Q are *predicate symbols*.

The sentences “ x is a student at the Virtual University” and “ x is a student at y ” are symbolized as $P(x)$ and $Q(x, y)$, where x and y are predicate variables and take values in appropriate sets. When concrete values are substituted in place of predicate variables, a statement results.

DEFINITION:

A predicate is a sentence that contains a finite number of variables and becomes a statement when specific values are substituted for the variables.

The domain of a predicate variable is the set of all values that may be substituted in place of the variable.

PRE-CONDITIONS AND POST-CONDITIONS:

Consider an algorithm that is designed to produce a certain final state from a given state. Both the initial and final states can be expressed as predicates involving the input and output variables.

Often the predicate describing the initial state is called the **pre-condition of the algorithm** and the predicate describing the final state is called the **post-condition of the algorithm**.

EXAMPLE:

1. Algorithm to compute a product of two nonnegative integers

pre-condition: The input variables m and n are nonnegative integers.

pot-condition: The output variable p equals $m \cdot n$.

2. Algorithm to find the quotient and remainder of the division of one positive integer by another

pre-condition: The input variables a and b are positive integers.

pot-condition: The output variable q and r are positive integers such that $a = b \cdot q + r$ and $0 \leq r < b$.

3. Algorithm to sort a one-dimensional array of real numbers

Pre-condition: The input variable $A[1], A[2], \dots, A[n]$ is a one-dimensional array of real numbers.

post-condition: The input variable $B[1], B[2], \dots, B[n]$ is a one-dimensional array of real numbers with same elements as $A[1], A[2], \dots, A[n]$ but with the property that $B[i] \leq B[j]$ whenever $i \leq j$.

THE DIVISION ALGORITHM:

[pre-condition: a is a nonnegative integer and d is a positive integer, $r = a$, and $q = 0$]

while ($r \geq d$)

1. $r := r - d$

2. $q := q + 1$

end while

[post-condition: q and r are nonnegative integers with the property that $a = q \cdot d + r$ and $0 \leq r < d$.]

LOOP INVARIANTS:

The method of loop invariants is used to prove correctness of a loop with respect to certain pre and post-conditions. It is based on the principle of mathematical induction.

[pre-condition for loop]

while (G)

[Statements in body of loop. None contain branching statements that lead outside the loop.]

end while[post-condition for loop]

DEFINITION:

A loop is defined as **correct with respect to its pre- and post-conditions** if, and only if, whenever the algorithm variables satisfy the pre-condition for the loop and the loop is executed, then the algorithm variables satisfy the post-condition of the loop.

THEOREM:

Let a **while** loop with guard G be given, together with pre- and post conditions that are predicates in the algorithm variables.

Also let a predicate $I(n)$, called the **loop invariant**, be given. If the following four properties are true, then the loop is correct with respect to its pre- and post-conditions.

I. Basis Property: The pre-condition for the loop implies that $I(0)$ is true before the first iteration of the loop.

II. Inductive property: If the guard G and the loop invariant $I(k)$ are both true for an integer $k \geq 0$ before an iteration of the loop, then $I(k + 1)$ is true after iteration of the loop.

III. Eventual Falsity of Guard: After a finite number of iterations of the loop, the guard becomes false.

IV. Correctness of the Post-Condition: If N is the least number of iterations after which G is false and $I(N)$ is true, then the values of the algorithm variables will be as specified in the post-condition of the loop.

PROOF:

Let $I(n)$ be a predicate that satisfies properties I-IV of the loop invariant theorem.

Properties I and II establish that:

For all integers $n \geq 0$, if the while loop iterates n times, then $I(n)$ is true.

Property III indicates that the guard G becomes false after a finite number N of iterations.

Property IV concludes that the values of the algorithm variables are as specified by the post-condition of the loop.

Lecture No.28

Division algorithm

**CORRECTNESS OF:
LOOP TO COMPUTE A PRODUCT
THE DIVISION ALGORITHM
THE EUCLIDEAN ALGORITHM**

A LOOP TO COMPUTE A PRODUCT:

[pre-condition: m is a nonnegative integer,
 x is a real number, $i = 0$, and $\text{product} = 0$.]

while ($i \neq m$)

1. $\text{product} := \text{product} + x$
2. $i := i + 1$

end while

[post-condition: $\text{product} = m \cdot x$]

PROOF:

Let the loop invariant be

$I(n)$: $i = n$ and $\text{product} = n \cdot x$

The guard condition G of the while loop is

G : $i \neq m$

I.Basis Property:

[$I(0)$ is true before the first iteration of the loop.]

$I(0)$: $i = 0$ and $\text{product} = 0 \cdot x = 0$

Which is true before the first iteration of the loop.

II.Inductive property:

[If the guard G and the loop invariant $I(k)$ are both true before a loop iteration (where $k \geq 0$), then $I(k + 1)$ is true after the loop iteration.]

Before execution of statement 1,

$$\text{product}_{\text{old}} = k \cdot x.$$

Thus the execution of statement 1 has the following effect:

$$\text{product}_{\text{new}} = \text{product}_{\text{old}} + x = k \cdot x + x = (k + 1) \cdot x$$

Similarly, before statement 2 is executed,

$$i_{\text{old}} = k,$$

So after execution of statement 2,

$$i_{\text{new}} = i_{\text{old}} + 1 = k + 1.$$

Hence after the loop iteration, the statement $I(k + 1)$ (i.e., $i = k + 1$ and $\text{product} = (k + 1) \cdot x$) is true. This is what we needed to show.

III.Eventual Falsity of Guard:

[After a finite number of iterations of the loop, the guard becomes false.]

IV.Correctness of the Post-Condition:

[If N is the least number of iterations after which G is false and $I(N)$ is true, then the values of the algorithm variables will be as specified in the post-condition of the loop.]

THE DIVISION ALGORITHM:

[pre-condition: a is a nonnegative integer and
 d is a positive integer, $r = a$, and $q = 0$]

while ($r \geq d$)
 1. $r := r - d$
 2. $q := q + 1$

end while

[post-condition: q and r are nonnegative integers with the property that $a = q \cdot d + r$ and $0 \leq r < d$.]

PROOF:

Let the loop invariant be

$$I(n): r = a - n \cdot d \text{ and } n = q.$$

The guard of the **while** loop is

$$G: r \geq d$$

I.Basis Property:

[$I(0)$ is true before the first iteration of the loop.]

$$I(0): r = a - 0 \cdot d = a \text{ and } 0 = q.$$

II.Inductive property:

[If the guard G and the loop invariant $I(k)$ are both true before a loop iteration (where $k \geq 0$), then $I(k + 1)$ is true after the loop iteration.]

$$I(k): r = a - k \cdot d \geq 0 \text{ and } k = q$$

$$I(k + 1): r = a - (k + 1) \cdot d \geq 0 \text{ and } k + 1 = q$$

$$\begin{aligned} r_{\text{new}} &= r - d \\ &= a - k \cdot d - d \\ &= a - (k + 1) \cdot d \\ q &= q + 1 \\ &= k + 1 \end{aligned}$$

also

$$\begin{aligned} r_{\text{new}} &= r - d \\ &\geq d - d = 0 \quad (\text{since } r \geq 0) \end{aligned}$$

Hence $I(k + 1)$ is true.

III.Eventual Falsity of Guard:

[After a finite number of iterations of the loop, the guard becomes false.]

IV.Correctness of the Post-Condition:

[If N is the least number of iterations after which G is false and $I(N)$ is true, then the values of the algorithm variables will be as specified in the post-condition of the loop.]

G is false and $I(N)$ is true.

That is, $r \geq d$ and $r = a - N \cdot d \geq 0$ and $N = q$.

$$\text{or } r = a - q \cdot d$$

$$\text{or } a = q \cdot d + r$$

Also combining the two inequalities involving r we get

$$0 \leq r < d$$

THE EUCLIDEAN ALGORITHM:

The greatest common divisor (gcd) of two integers a and b is the largest integer that divides both a and b . For example, the gcd of 12 and 30 is 6.

The Euclidean algorithm takes integers A and B with $A > B \geq 0$ and compute their greatest common divisor.

HAND CALCULATION OF gcd:Use the Euclidean algorithm to find $\text{gcd}(330, 156)$ **SOLUTION:**

$$\begin{array}{r}
 156 \overline{) 330} \\
 \underline{312} \\
 18 \\
 12 \overline{) 18} \\
 \underline{12} \\
 6
 \end{array}
 \qquad
 \begin{array}{r}
 18 \overline{) 156} \\
 \underline{144} \\
 12 \\
 6 \overline{) 12} \\
 \underline{12} \\
 0
 \end{array}$$

Hence $\text{gcd}(330, 156) = 6$ **EXAMPLE:**Use the Euclidean algorithm to find $\text{gcd}(330, 156)$ **Solution:**

1. Divide 330 by 156:

This gives $330 = 156 \cdot 2 + 18$

2. Divide 156 by 18:

This gives $156 = 18 \cdot 8 + 12$

3. Divide 18 by 12:

This gives $18 = 12 \cdot 1 + 6$

4. Divide 12 by 6:

This gives $12 = 6 \cdot 2 + 0$

Hence $\text{gcd}(330, 156) = 6$.**LEMMA:**If a and b are any integers with $b \neq 0$ and q and r are nonnegative integers such that $a = q \cdot b + r$

then

$\text{gcd}(a, b) = \text{gcd}(b, r)$

[pre-condition: A and B are integers with $A > B \geq 0, a = A, b = B, r = B.$]**while** ($b \neq 0$)1. $r := a \bmod b$ 2. $a := b$

3. $b := r$

end while[post-condition: $a = \gcd(A, B)$]

PROOF:

Let the **loop invariant** be

$$I(n): \gcd(a, b) = \gcd(A, B) \text{ and } 0 \leq b < a.$$

The guard of the **while** loop is

$$G: b \neq 0$$

I.Basis Property:

[$I(0)$ is true before the first iteration of the loop.]

$$I(0): \gcd(a, b) = \gcd(A, B) \text{ and } 0 \leq b < a.$$

According to the precondition,

$$a = A, b = B, r = B, \text{ and } 0 \leq B < A.$$

Hence $I(0)$ is true before the first iteration of the loop.

II.Inductive property:

[If the guard G and the loop invariant $I(k)$ are both true before a loop iteration (where $k \geq 0$), then $I(k + 1)$ is true after the loop iteration.]

Since $I(k)$ is true before execution of the loop we have,

$$\gcd(a_{\text{old}}, b_{\text{old}}) = \gcd(A, B) \text{ and } 0 \leq b_{\text{old}} < a_{\text{old}}$$

After execution of statement 1,

$$\begin{aligned} r_{\text{new}} &= a_{\text{old}} \bmod b_{\text{old}} \text{ Thus,} \\ a_{\text{old}} &= b_{\text{old}} \cdot q + r_{\text{new}} \quad \text{for some integer } q \end{aligned}$$

with,

$$0 \leq r_{\text{new}} < b_{\text{old}}.$$

But

$$\gcd(a_{\text{old}}, b_{\text{old}}) = \gcd(b_{\text{old}}, r_{\text{old}})$$

and we have,

$$\gcd(b_{\text{old}}, r_{\text{new}}) = \gcd(A, B)$$

When statements 2 and 3 are executed,

$$a_{\text{new}} = b_{\text{old}} \text{ and } b_{\text{new}} = r_{\text{new}}$$

It follows that

$$\gcd(a_{\text{new}}, b_{\text{new}}) = \gcd(A, B)$$

Also,

$$0 \leq r_{\text{new}} < b_{\text{old}}$$

becomes

$$0 \leq b_{\text{new}} < a_{\text{new}}$$

Hence $I(k + 1)$ is true.

III.Eventual Falsity of Guard:

[After a finite number of iterations of the loop, the guard becomes false.]

IV.Correctness of the Post-Condition:

[If N is the least number of iterations after which G is false and $I(N)$ is true, then the values of the algorithm variables will be as specified in the post-condition of the loop.]

Lecture No.29 Combinatorics

COMBINATORICS

THE SUM RULE

THE PRODUCT RULE

COMBINATORICS:

Combinatorics is the mathematics of counting and arranging objects. Counting of objects with certain properties (enumeration) is required to solve many different types of problem. For example, counting is used to:

- (i) Determine number of ordered or unordered arrangement of objects.
- (ii) Generate all the arrangements of a specified kind which is important in computer simulations.
- (iii) Compute probabilities of events.
- (iv) Analyze the chance of winning games, lotteries etc.
- (v) Determine the complexity of algorithms.

THE SUM RULE:

If one event can occur in n_1 ways, a second event can occur in n_2 (different) ways, then the total number of ways in which exactly one of the events (i.e., first or second) can occur is $n_1 + n_2$.

EXAMPLE:

Suppose there are 7 different optional courses in Computer Science and 3 different optional courses in Mathematics. Then there are $7 + 3 = 10$ choices for a student who wants to take one optional course.

EXERCISE:

A student can choose a computer project from one of the three lists. The three lists contain 23, 15 and 19 possible projects, respectively. How many possible projects are there to choose from?

SOLUTION:

The student can choose a project from the first list in 23 ways, from the second list in 15 ways, and from the third list in 19 ways. Hence, there are $23 + 15 + 19 = 57$ projects to choose from.

GENERALIZED SUM RULE

If one event can occur in n_1 ways,
 a second event can occur in n_2 ways,
 a third event can occur in n_3 ways,

then there are

$$n_1 + n_2 + n_3 + \dots$$

ways in which exactly one of the events can occur.

SUM RULE IN TERMS OF SETS:

If A_1, A_2, \dots, A_m are finite disjoint sets, then the number of elements in the union of these sets is the sum of the number of elements in them.

If $n(A_i)$ denotes the number of elements in set A_i , then

$$n(A_1 \cup A_2 \cup \dots \cup A_m) = n(A_1) + n(A_2) + \dots + n(A_m)$$

where $A_i \cap A_j = \phi$ if $i \neq j$

THE PRODUCT RULE:

If one event can occur in n_1 ways and if for each of these n_1 ways, a second event can occur in n_2 ways, then the total number of ways in which both events occur is $n_1 \cdot n_2$.

EXAMPLE:

Suppose there are 7 different optional courses in Computer Science and 3 different optional courses in Mathematics. A student who wants to take one optional course of each subject, there are

$$7 \times 3 = 21 \quad \text{choices.}$$

EXAMPLE:

The chairs of an auditorium are to be labeled with two characters, a letter followed by a digit.

What is the largest number of chairs that can be labeled differently?

SOLUTION:

The procedure of labeling a chair consists of two events, namely,

(i) Assigning one of the 26 letters: A, B, C, ..., Z and

(ii) Assigning one of the 10 digits: 0, 1, 2, ..., 9

By product rule, there are $26 \times 10 = 260$

different ways that a chair can be labeled by both a letter and a digit.

GENERALIZED PRODUCT RULE:

If some event can occur in n_1 different ways, and if, following this event, a second event can occur in n_2 different ways, and following this second event, a third event can occur in n_3 different ways, ..., then the number of ways all the events can occur in the order indicated is

$$n_1 \cdot n_2 \cdot n_3 \cdot \dots$$

PRODUCT RULE IN TERMS OF SETS:

If A_1, A_2, \dots, A_m are finite sets, then the number of elements in the Cartesian product of these sets is the product of the number of elements in each set.

If $n(A_i)$ denotes the number of elements in set A_i , then

$$n(A_1 \times A_2 \times \dots \times A_m) = n(A_1) \cdot n(A_2) \cdot \dots \cdot n(A_m)$$

EXERCISE:

Find the number n of ways that an organization consisting of 15 members can elect a president, treasurer, and secretary. (assuming no person is elected to more than one position)

SOLUTION:

The president can be elected in 15 different ways; following this, the treasurer can be elected in 14 different ways; and following this, the secretary can be elected in 13 different ways. Thus, by product rule, there are

$$n = 15 \times 14 \times 13 = 2730$$

different ways in which the organization can elect the officers.

EXERCISE:

There are four bus lines between A and B; and three bus lines between B and C. Find the number of ways a person can travel:

- By bus from A to C by way of B;
- Round trip by bus from A to C by way of B;
- Round trip by bus from A to C by way of B, if the person does not want to use a bus line more than once.

SOLUTION:

(a) There are 4 ways to go from A to B and 3 ways to go from B to C; hence there are $4 \times 3 = 12$ ways to go from A to C by way of B.

(b) The person will travel from A to B to C to B to A for the round trip.

i.e. $(A \rightarrow B \rightarrow C \rightarrow B \rightarrow A)$

The person can travel 4 ways from A to B and 3 way from B to C and back.

i.e., $A \xrightarrow{4} B \xrightarrow{3} C \xrightarrow{3} B \xrightarrow{4} A$

Thus there are $4 \times 3 \times 3 \times 4 = 144$ ways to travel the round trip.

(c) The person can travel 4 ways from A to B and 3 ways from B to C, but only 2 ways from C to B and 3 ways from B to A, since bus line cannot be used more than once. Thus

i.e., $A \xrightarrow{4} B \xrightarrow{3} C \xrightarrow{2} B \xrightarrow{3} A$

Hence there are $4 \times 3 \times 2 \times 3 = 72$ ways to travel the round trip without using a bus line more than once.

EXERCISE:

A bit string is a sequence of 0's and 1's. How many bit string are there of length 4?

SOLUTION:

Each bit (binary digit) is either 0 or 1.

Hence, there are 2 ways to choose each bit. Since we have to choose four bits therefore, the product rule shows, there are a total of $2 \times 2 \times 2 \times 2 = 2^4 = 16$ different bit strings of length four.

EXERCISE:

How many bit strings of length 8

- begin with a 1? (ii) begin and end with a 1?

SOLUTION:

(i) If the first bit (left most bit) is a 1, then it can be filled in only one way. Each of the remaining seven positions in the bit string can be filled in 2 ways (i.e., either by 0 or 1).

Hence, there are $1 \times 2 \times 2 \times 2 \times 2 \times 2 \times 2 \times 2 = 2^7 = 128$

different bit strings of length 8 that begin with a 1.

(ii) If the first and last bit in an 8 bit string is a 1, then only the intermediate six bits can be filled in 2 ways, i.e. by a 0 or 1. Hence there are $1 \times 2 \times 2 \times 2 \times 2 \times 2 \times 1 = 2^6 = 64$

different bit strings of length 8 that begin and end with a 1.

EXERCISE:

Suppose that an automobile license plate has three letters followed by three digits.

- How many different license plates are possible?

SOLUTION:

Each of the three letters can be written in 26 different ways, and each of the three digits can be written in 10 different ways.

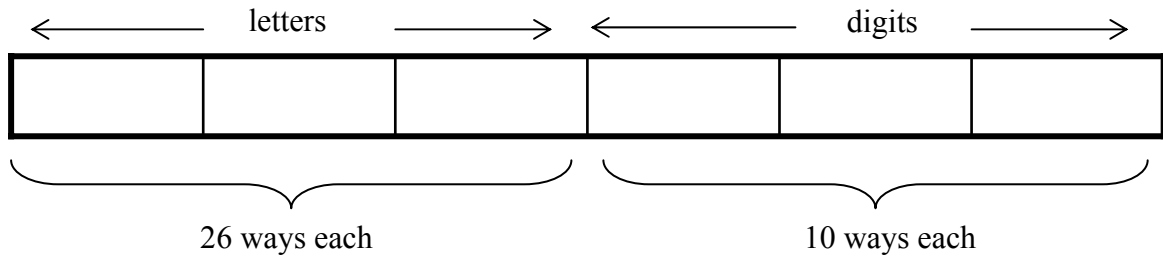

Hence, by the product rule, there is a total of
 $26 \times 26 \times 26 \times 10 \times 10 \times 10 = 17,576,000$
 different license plates possible.

(b) How many license plates could begin with A and end on 0?

SOLUTION:

The first and last place can be filled in one way only, while each of second and third place can be filled in 26 ways and each of fourth and fifth place can be filled in 10 ways.

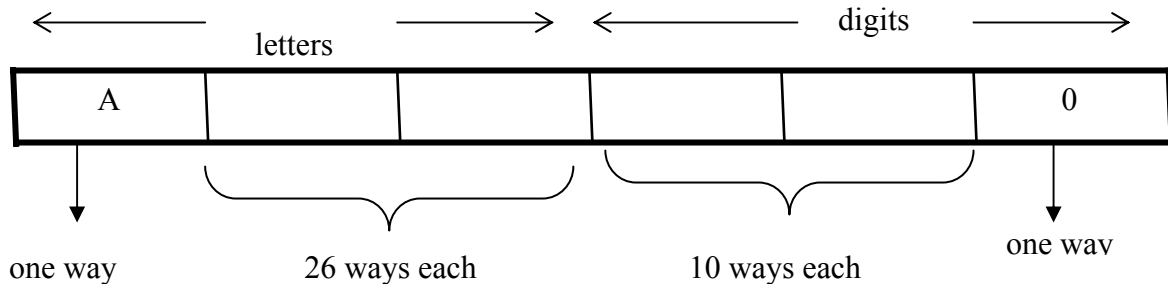

Number of license plates that begin with A and end in 0 are

$$1 \times 26 \times 26 \times 10 \times 10 \times 1 = 67600$$

(c) How many license plates begin with PQR

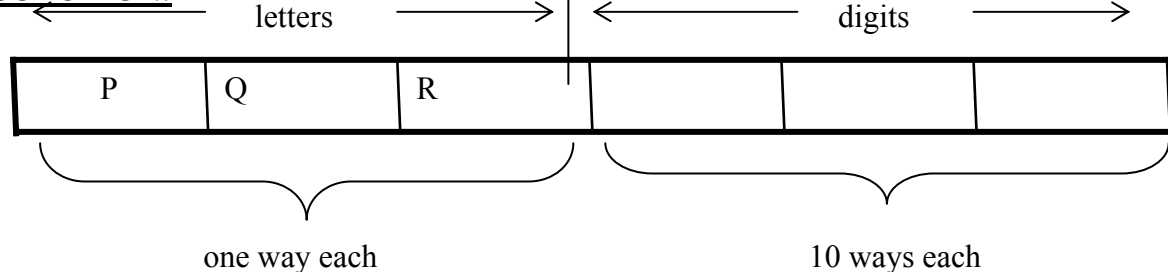
SOLUTION:

Number of license plates that begin with PQR are

$$1 \times 1 \times 1 \times 10 \times 10 \times 10 = 1000$$

(d) How many license plates are possible in which all the letters and digits are distinct?

SOLUTION:

The first letter place can be filled in 26 ways. Since, the second letter place should contain a different letter than the first, so it can be filled in 25 ways. Similarly, the third letter place can be filled in 24 ways. And the digits can be respectively filled in 10, 9, and 8 ways.

Hence; number of license plates in which all the letters and digits are distinct are
 $26 \times 25 \times 24 \times 10 \times 9 \times 8 = 11, 232, 000$

(e) How many license plates could begin with AB and have all three letters and digits distinct.

SOLUTION:

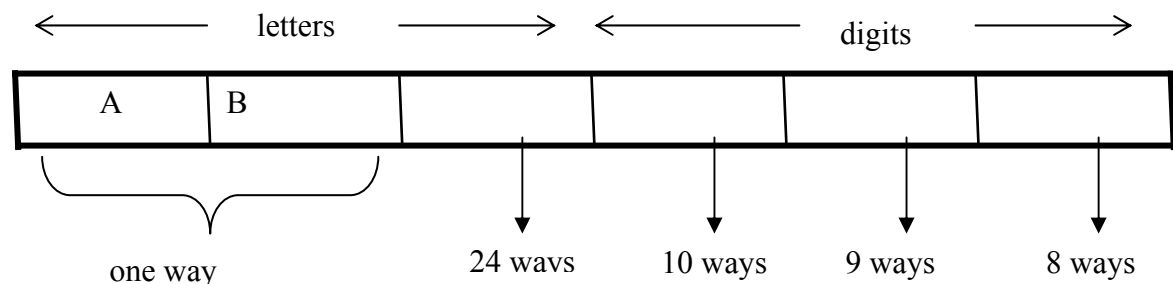

The first two letters places are fixed (to be filled with A and B), so there is only one way to fill them. The third letter place should contain a letter different from A & B, so there are 24 ways to fill it.

The three digit positions can be filled in 10 and 8 ways to have distinct digits.

Hence, desired number of license plates are

$$1 \times 1 \times 24 \times 10 \times 9 \times 8 = 17280$$

EXERCISE:

A variable name in a programming language must be either a letter or a letter followed by a digit. How many different variable names are possible?

SOLUTION:

First consider variable names one character in length. Since such names consist of a single letter, there are 26 variable names of length 1.

Next, consider variable names two characters in length. Since the first character is a letter, there are 26 ways to choose it. The second character is a digit, there are 10 ways to choose it. Hence, to construct variable name of two characters in length, there are

$$26 \times 10 = 260 \text{ ways.}$$

Finally, by sum rule, there are $26 + 260 = 286$ possible variable names in the programming language.

EXERCISE:

(a) How many bit strings consist of from one through four digits?

(b) How many bit strings consist of from five through eight digits?

SOLUTION:

(a) Number of bit strings consisting of 1 digit = 2

$$\text{Number of bit strings consisting of 2 digits} = 2 \cdot 2 = 2^2$$

$$\text{Number of bit strings consisting of 3 digits} = 2 \cdot 2 \cdot 2 = 2^3$$

$$\text{Number of bit strings consisting of 4 digits} = 2 \cdot 2 \cdot 2 \cdot 2 = 2^4$$

Hence by sum rule, the total number of bit strings consisting of one through four digit is

$$2+2^2+2^3+2^4 = 2 + 4 + 8 + 16 = 30$$

(b) Number of bit strings of 5 digits = 2^5

Number of bit strings of 6 digits = 2^6

Number of bit strings of 7 digits = 2^7

Number of bit strings of 8 digits = 2^8

Hence, by sum rule, the total number of bit strings consisting of five through eight digit is

$$2^5 + 2^6 + 2^7 + 2^8 = 480$$

EXERCISE:

How many three-digit integers are divisible by 5?

SOLUTION:

Integers that are divisible by 5, end either in 5 or in 0.

CASE-I (Integers that end in 0)

There are nine choices for the left-most digit (the digits 1 through 9) and ten choices for the middle digit.(the digits 0 through 9) Hence, total number of 3 digit integers that end in 0 is

$$9 \times 10 \times 1 = 90$$

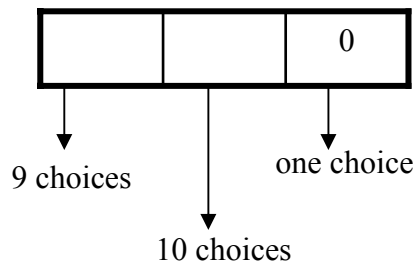

CASE-II (Integer that end in 5)

There are nine choices for the left-most digit and ten choices for the middle digit

Hence, total number of 3 digit integers that end in 5 is

$$9 \times 10 \times 1 = 90$$

Finally, by sum rule, the number of 3 digit integers that are divisible by 5 is

$$90 + 90 = 180$$

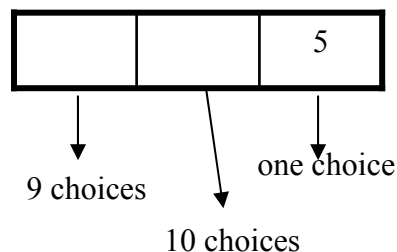

EXERCISE:

A computer access code word consists of from one to three letters of English alphabets with repetitions allowed.

How many different code words are possible.

SOLUTION:

Number of code words of length 1 = 26^1

Number of code words of length 2 = 26^2

Number of code words of length 3 = 26^3

Hence, the total number of code words = $26^1 + 26^2 + 26^3$
 $= 18,278$

NUMBER OF ITERATIONS OF A NESTED LOOP:

Determine how many times the inner loop will be iterated when the following algorithm is implemented and run

```

    for i = 1 to 4
for j = 1 to 3
    [Statement in body of inner loop.
                                     None contain branching statements
                                     that lead out of the inner loop.]
    next j
next i

```

SOLUTION:

The outer loop is iterated four times, and during each iteration of the outer loop, there are three iterations of the inner loop. Hence, by product rules the total number of iterations of inner loop is $4 \cdot 3 = 12$

EXERCISE:

Determine how many times the inner loop will be iterated when the following algorithm is implemented and run.

```

    for i = 5 to 50
for j = 10 to 20
    [Statement in body of inner loop.
                                     None contain branching statements
                                     that lead out of the inner loop.]
    next j
next i

```

SOLUTION:

The outer loop is iterated $50 - 5 + 1 = 46$ times and during each iteration of the outer loop there are $20 - 10 + 1 = 11$ iterations of the inner loop. Hence by product rule, the total number of iterations of the inner loop is $46 \cdot 11 = 506$

EXERCISE:

Determine how many times the inner loop will be iterated when the following algorithm is implemented and run.

```

    for i = 1 to 4
for j = 1 to i
    [Statements in body of inner loop.
                                     None contain branching statements
                                     that lead outside the loop.]

```

```
next j
next i
```

SOLUTION:

The outer loop is iterated 4 times, but during each iteration of the outer loop, the inner loop iterates different number of times.

For first iteration of outer loop, inner loop iterates 1 times.

For second iteration of outer loop, inner loop iterates 2 times.

For third iteration of outer loop, inner loop iterates 3 times.

For fourth iteration of outer loop, inner loop iterates 4 times.

Hence, total number of iterations of inner loop = $1 + 2 + 3 + 4 = 10$

Lecture No.30 Permutations

FACTORIAL K-SAMPLE K-PERMUTATION

FACTORIAL OF A POSITIVE INTEGER:

For each positive integer n , its factorial is defined to be the product of all the integers from 1 to n and is denoted $n!$. Thus $n! = n(n-1)(n-2) \dots 3 \cdot 2 \cdot 1$

In addition, we define

$$0! = 1$$

REMARK:

$n!$ can be recursively defined as

Base: $0! = 1$

Recursion $n! = n(n-1)!$ for each positive integer n .

Compute each of the following

- | | |
|---------------------------|------------------------------|
| (i) $\frac{7!}{5!}$ | (ii) $(-2)!$ |
| (iii) $\frac{(n+1)!}{n!}$ | (iv) $\frac{(n-1)!}{(n+1)!}$ |

SOLUTION:

$$(i) \quad \frac{7!}{5!} = \frac{7 \cdot 6 \cdot 5!}{5!} = 7 \cdot 6 = 42$$

$$(ii) \quad (-2)! \text{ is not defined}$$

$$(iii) \quad \frac{(n+1)!}{n!} = \frac{(n+1)n!}{n!} = n+1$$

$$(iv) \quad \frac{(n-1)!}{(n+1)!} = \frac{(n-1)!}{(n+1) \cdot n \cdot (n-1)!} = \frac{1}{(n+1)n} = \frac{1}{n^2 + n}$$

EXERCISE:

Write in terms of factorials.

- | | |
|---|----------------------------------|
| (i) $25 \cdot 24 \cdot 23 \cdot 22$ | (ii) $n(n-1)(n-2) \dots (n-r+1)$ |
| (iii) $\frac{n(n-1)(n-2) \dots (n-r+1)}{1 \cdot 2 \cdot 3 \dots (r-1) \cdot r}$ | |

SOLUTION:

$$(i) \quad 25 \cdot 24 \cdot 23 \cdot 22 = \frac{25 \cdot 24 \cdot 23 \cdot 22 \cdot 21!}{21!} = \frac{25!}{21!}$$

$$(ii) \quad n(n-1)(n-2) \dots (n-r+1) = \frac{n(n-1)(n-2) \dots (n-r+1)(n-r)!}{(n-r)!}$$

$$= \frac{n!}{(n-r)!}$$

$$\begin{aligned}
 \text{(iii)} \quad \frac{n(n-1)(n-2)\cdots(n-r+1)}{1 \cdot 2 \cdot 3 \cdots (r-1) \cdot r} &= \frac{n(n-1)(n-2)\cdots(n-r+1)}{r!} \\
 &= \frac{n(n-1)(n-2)\cdots(n-r+1)(n-r)!}{r!(n-r)!} \\
 &= \frac{n!}{r!(n-r)!}
 \end{aligned}$$

COUNTING FORMULAS:

From a given set of n distinct elements, one can choose k elements in different ways. The number of selections of elements varies according as:

- (i) elements may or may not be repeated.
- (ii) the order of elements may or may not matter.

These two conditions therefore lead us to four counting methods summarized in the following table.

	ORDER MATTERS	ORDER DOES NOT MATTER
REPETITION ALLOWED	k-sample	k-selection
REPETITION NOT ALLOWED	k-permutation	k-combination

K-SAMPLE:

A k -sample of a set of n elements is a choice of k elements taken from the set of n elements such that the order of elements matters and elements can be repeated.

REMARK:

With k -sample, repetition of elements is allowed, therefore, k need not be less than or equal to n . i.e. k is independent of n .

FORMULA FOR K-SAMPLE:

Suppose there are n distinct elements and we draw a k -sample from it. The first element of the k -sample can be drawn in n ways. Since, repetition of elements is allowed, so the second element can also be drawn in n ways.

Similarly each of third, fourth, ..., k -th element can be drawn in n ways.

Hence, by product rule, the total number of ways in which a k -sample can be drawn from n distinct elements is

$$\begin{aligned}
 &n \cdot n \cdot n \cdots n \quad (\text{k-times}) \\
 &= n^k
 \end{aligned}$$

EXERCISE:

How many possible outcomes are there when a fair coin is tossed three times.

SOLUTION:

Each time a coin is tossed its outcome is either a head (H) or a tail (T). Hence in successive tosses, H and T are repeated. Also the order in which they appear is important. Accordingly, the problem is of 3-samples from a set of two elements H and T. [k = 3, n = 2]

$$\begin{aligned}\text{Hence number of samples} &= n^k \\ &= 2^3 = 8\end{aligned}$$

These 8-samples may be listed as:

HHH, HHT, HTH, THH, HTT, THT, TTH, TTT

EXERCISE:

Suppose repetition of digits is permitted.

(a) How many three-digit numbers can be formed from the six digits 2, 3, 4, 5, 7 and 9

SOLUTION:

Given distinct elements = n = 6

Digits to be chosen = k = 3

While forming numbers, order of digits is important. Also digits may be repeated.

Hence, this is the case of 3-sample from 6 elements.

$$\text{Number of 3-digit numbers} = n^k = 6^3 = 216$$

(b) How many of these numbers are less than 400?

SOLUTION:

From the given six digits 2, 3, 4, 5, 7 and 9, a three-digit number would be less than 400 if and only if its first digit is either 2 or 3.

The next two digits positions may be filled with any one of the six digits.

Hence, by product rule, there are

$$2 \cdot 6 \cdot 6 = 72$$

three-digit numbers less than 400.

(c) How many are even?

SOLUTION:

A number is even if its right most digit is even. Thus, a 3-digit number formed by the digits 2, 3, 4, 5, 7 and 9 is even if its last digit is 2 or 4. Thus the last digit position may be filled in 2 ways only while each of the first two positions may be filled in 6 ways.

Hence, there are

$$6 \cdot 6 \cdot 2 = 72$$

3-digit even numbers.

(d) How many are odd?

SOLUTION:

A number is odd if its right most digit is odd. Thus, a 3-digit number formed by the digits 2, 3, 4, 5, 7 and 9 is odd if its last digit is one of 3, 5, 7, 9. Thus, the last digit position may be filled in 4 ways, while each of the first two positions may be filled in 6 ways.

Hence, there are $6 \cdot 6 \cdot 4 = 144$

3-digit odd numbers.

(e) How many are multiples of 5?

SOLUTION:

A number is a multiple of 5 if its right most digit is either 0 or 5. Thus, a 3-digit number formed by the digits 2, 3, 4, 5, 7 and 9 is multiple of 5 if its last digit is 5. Thus, the last digit position may be filled in only one way, while each of the first two positions may be filled in 6 ways.

Hence, there are $6 \cdot 6 \cdot 1 = 36$

3-digit numbers that are multiple of 5.

EXERCISE:

A box contains 10 different colored light bulbs. Find the number of ordered samples of size 3 with replacement.

SOLUTION:

Number of light bulbs = $n = 10$

Bulbs to be drawn = $k = 3$

Since bulbs are drawn with replacement, so repetition is allowed. Also while drawing a sample, order of elements in the sample is important.

Hence number of samples of size 3 = n^k
 $= 10^3$
 $= 1000$

EXERCISE:

A multiple choice test contains 10 questions; there are 4 possible answers for each question.

(a) How many ways can a student answer the questions on the test if every question is answered?

(b) How many ways can a student answer the questions on the test if the student can leave answers blank?

SOLUTION:

(a) Each question can be answered in 4 ways. Suppose answers are labeled as A, B, C, D. Since label A may be used as the answer of more than one question. So repetition is allowed. Also the order in which A, B, C, D are choosed as answers for 10 questions is important. Hence, this is the one of k-sample, in which

$n = \text{no. of distinct labels} = 4$

$k = \text{no. of labels selected for answering} = 10$

\therefore No. of ways to answer 10 questions = n^k
 $= 4^{10}$
 $= 1048576$

(b) If the student can leave answers blank, then in addition to the four answers, a fifth option to leave answer blank is possible. Hence, in such case

$n = 5$

and $k = 10$ (as before)

\therefore No. of possible answers = n^k
 $= 5^{10}$
 $= 9765625$

k-PERMUTATION:

A k-permutation of a set of n elements is a selection of k elements taken from the set of n elements such that the order of elements matters but repetition of the elements is not allowed. The number of k-permutations of a set of n elements is denoted $P(n, k)$ or ${}_n P_k$.

REMARK:

1. With k-permutation, repetition of elements is not allowed, therefore $k \leq n$.
2. The wording “number of permutations of a set with n elements” means that all n elements are to be permuted, so that $k = n$.

FORMULA FOR k-PERMUTATION:

Suppose a set of n elements is given. Formation of a k-permutation means that we have an ordered selection of k elements out of n, where elements cannot be repeated.

1st element can be selected in n ways

2nd element can be selected in (n-1) ways

3rd element can be selected in (n-2) ways

.....

kth element can be selected in (n-(k-1)) ways

Hence, by product rule, the number of ways to form a k-permutation is

$$\begin{aligned}
 P(n, k) &= n \cdot (n-1) \cdot (n-2) \cdots (n-(k-1)) \\
 &= n \cdot (n-1) \cdot (n-2) \cdots (n-k+1) \\
 &= \frac{[n \cdot (n-1) \cdot (n-2) \cdots (n-k+1)][(n-k)(n-k-1) \cdots 3 \cdot 2 \cdot 1]}{[(n-k)(n-k-1) \cdots 3 \cdot 2 \cdot 1]} \\
 &= \frac{n!}{(n-k)!}
 \end{aligned}$$

EXERCISE:

How many 2-permutation are there of {W, X, Y, Z}? Write them all.

SOLUTION:

Number of 2-permutation of 4 elements is

$$\begin{aligned}
 P(4, 2) &= {}_4 P_2 = \frac{4!}{(4-2)!} \\
 &= \frac{4 \cdot 3 \cdot 2!}{2!} \\
 &= 4 \cdot 3 = 12
 \end{aligned}$$

These 12 permutations are:

WX, WY, WZ,

XW, XY, XZ,

YW, YX, YZ,
ZW, ZX, ZY.

EXERCISE:

Find (a) $P(8, 3)$ (b) $P(8, 8)$
(c) $P(8, 1)$ (d) $P(6, 8)$

SOLUTION:

$$(a) \quad P(8, 3) = \frac{8!}{(8-3)!} = 8 \cdot 7 \cdot 6 = 336$$

$$(b) \quad P(8, 8) = \frac{8!}{(8-8)!} = \frac{8!}{0!} = 8! = 40320 \quad (\text{as } 0! = 1)$$

$$(c) \quad P(8, 1) = \frac{8!}{(8-1)!} = \frac{8 \cdot 7!}{7!} = 8$$

(d) $P(6, 8)$ is not defined, since the second

EXERCISE: integer cannot exceed the first integer.

Find n if

(a) $P(n, 2) = 72$ (b) $P(n, 4) = 42 P(n, 2)$

SOLUTION:

(a) Given $P(n, 2) = 72$

$$\Rightarrow n \cdot (n-1) = 72 \quad (\text{by using the definition of permutation})$$

$$\Rightarrow n^2 - n = 72$$

$$\Rightarrow n^2 - n - 72 = 0$$

$$\Rightarrow n = 9, -8$$

Since n must be positive, so the only acceptable value of n is 9.

(b) Given $P(n, 4) = 42P(n, 2)$

$$\Rightarrow n(n-1)(n-2)(n-3) = 42n(n-1) \quad (\text{by using the definition of permutation})$$

$$\Rightarrow (n-2)(n-3) = 42 \quad \text{if } n \neq 0, n \neq 1$$

$$\Rightarrow n^2 - 5n + 6 = 42$$

$$\text{or } n^2 - 5n - 36 = 0$$

$$\text{or } (n-9)(n+4) = 0$$

$$\Rightarrow n = 9, -4$$

Since n must be positive, the only answer is $n = 9$

EXERCISE:

Prove that for all integers $n \geq 3$

$$P(n+1, 3) - P(n, 3) = 3P(n, 2)$$

SOLUTION:

Suppose n is an integer greater than or equal to 3

$$\begin{aligned} \text{Now L.H.S} &= P(n+1, 3) - P(n, 3) \\ &= (n+1)(n)(n-1) - n(n-1)(n-2) \\ &= n(n-1)[(n+1) - (n-2)] \\ &= n(n-1)[n+1 - n + 2] \\ &= 3n(n-1) \\ \text{R.H.S} &= 3P(n, 2) \\ &= 3 \cdot n(n-1) \end{aligned}$$

Thus L.H.S = R.H.S. Hence the result.

EXERCISE:

(a) How many ways can five of the letters of the word ALGORITHM be selected and written in a row?

(b) How many ways can five of the letters of the word ALGORITHM be selected and written in a row if the first two letters must be TH?

SOLUTION:

(a) The answer equals the number of 5-permutation of a set of 9 elements and

$$P(9,5) = \frac{9!}{(9-5)!} = 9 \cdot 8 \cdot 7 \cdot 6 \cdot 5 = 15120$$

(b) Since the first two letters must be TH hence we need to choose the remaining three letters out of the left $9 - 2 = 7$ alphabets.

Hence, the answer is the number of 3-permutations of a set of seven elements which is

$$P(7,3) = \frac{7!}{(7-3)!} = 7 \cdot 6 \cdot 5 = 210$$

EXERCISE:

Find the number of ways that a party of seven persons can arrange themselves in a row of seven chairs.

SOLUTION:

The seven persons can arrange themselves in a row in $P(7,7)$ ways.

Now

$$P(7,7) = \frac{7!}{(7-7)!} = \frac{7!}{0!} = 7!$$

EXERCISE:

A debating team consists of three boys and two girls. Find the number n of ways they can sit in a row if the boys and girls are each to sit together.

SOLUTION:

There are two ways to distribute them according to sex: BBBGG or GGBBB.

In each case

the boys can sit in a row in $P(3,3) = 3! = 6$ ways, and

the girls can sit in

$$P(2,2) = 2! = 2 \text{ ways and}$$

Every row consist of boy and girl which is $= 2! = 2$

Thus

$$\begin{aligned} \text{The total number of ways} &= n = 2 \cdot 3! \cdot 2! \\ &= 2 \cdot 6 \cdot 2 = 24 \end{aligned}$$

EXERCISE:

Find the number n of ways that five large books, four medium sized book, and three small books can be placed on a shelf so that all books of the same size are together.

SOLUTION:

In each case, the large books can be arranged among themselves in $P(5,5) = 5!$ ways, the medium sized books in $P(4,4) = 4!$ ways, and the small books in $P(3,3) = 3!$ ways.

The three blocks of books can be arranged on the shelf in $P(3,3) = 3!$ ways.

Thus

$$\begin{aligned}n &= 3! \cdot 5! \cdot 4! \cdot 3! \\ &= 103680\end{aligned}$$

Lecture No.31 Combinations

K-COMBINATIONS

K-SELECTIONS

K-COMBINATIONS:

With a k -combinations the order in which the elements are selected does not matter and the elements cannot repeat.

DEFINITION:

A k -combination of a set of n elements is a choice of k elements taken from the set of n elements such that the order of the elements does not matter and elements can't be repeated.

The symbol $C(n, k)$ denotes the number of k -combinations that can be chosen from a set of n elements.

NOTE:

k -combinations are also written nC_k as or $\binom{n}{k}$

REMARK:

With k -combinations of a set of n elements, repetition of elements is not allowed, therefore, k must be less than or equal to n , i.e., $k \leq n$.

EXAMPLE:

Let $X = \{a, b, c\}$. Then 2-combinations of the 3 elements of the set X are: $\{a, b\}$, $\{a, c\}$, and $\{b, c\}$. Hence $C(3,2) = 3$.

EXERCISE:

Let $X = \{a, b, c, d, e\}$.

List all 3-combinations of the 5 elements of the set X , and hence find the value of $C(5,3)$.

SOLUTION:

Then 3-combinations of the 5 elements of the set X are:

$\{a, b, c\}$, $\{a, b, d\}$, $\{a, b, e\}$, $\{a, c, d\}$, $\{a, c, e\}$,
 $\{a, d, e\}$, $\{b, c, d\}$, $\{b, c, e\}$, $\{b, d, e\}$, $\{c, d, e\}$

Hence $C(5, 3) = 10$

PERMUTATIONS AND COMBINATIONS:

EXAMPLE:

Let $X = \{A, B, C, D\}$.

The 3-combinations of X are:

$\{A, B, C\}$, $\{A, B, D\}$, $\{A, C, D\}$, $\{B, C, D\}$

Hence $C(4, 3) = 4$

The 3-permutations of X can be obtained from 3-combinations of X as follows.

$ABC, ACB, BAC, BCA, CAB, CBA$

$ABD, ADB, BAD, BDA, DAB, DBA$

$ACD, ADC, CAD, CDA, DAC, DCA$

$BCD, BDC, CBD, CDB, DBC, DCB$

So that $P(4, 3) = 24 = 4 \cdot 3 \cdot 2 = 4 \cdot 3!$

Clearly $P(4, 3) = C(4, 3) \cdot 3!$

In general we have, $P(n, k) = C(n, k) \cdot k!$

In general we have,

$$P(n, k) = C(n, k) \cdot k!$$

or
$$C(n, k) = \frac{P(n, k)}{k!}$$

But we know that
$$P(n, k) = \frac{n!}{(n-k)!}$$

Hence,
$$C(n, k) = \frac{n!}{(n-k)!k!}$$

COMPUTING $C(n, k)$

EXAMPLE:

Compute $C(9, 6)$.

SOLUTION:
$$\begin{aligned} C(9, 6) &= \frac{9!}{(9-6)!6!} \\ &= \frac{9 \cdot 8 \cdot 7 \cdot 6!}{3! \cdot 6!} \\ &= \frac{9 \cdot 8 \cdot 7}{3 \cdot 2} \\ &= 84 \end{aligned}$$

SOME IMPORTANT RESULTS

- (a) $C(n, 0) = 1$
- (b) $C(n, n) = 1$
- (c) $C(n, 1) = n$
- (d) $C(n, 2) = n(n-1)/2$
- (e) $C(n, k) = C(n, n-k)$
- (f) $C(n, k) + C(n, k+1) = C(n+1, k+1)$

EXERCISE:

A student is to answer eight out of ten questions on an exam.

- (a) Find the number m of ways that the student can choose the eight questions
- (b) Find the number m of ways that the student can choose the eight questions, if the first three questions are compulsory.

SOLUTION:

- (a) The eight questions can be answered in $m = C(10, 8) = 45$ ways.
- (b) The eight questions can be answered in $m = C(7, 5) = 21$ ways.

EXERCISE:

An examination paper consists of 5 questions in section A and 5 questions in section B. A total of 8 questions must be answered. In how many ways can a student select the questions if he is to answer at least 4 questions from section A.

SOLUTION:

There are two possibilities:

- (a) The student answers 4 questions from section A and 4 questions from section B. The number of ways 8 questions can be answered taking 4 questions from section A and 4 questions from section B are

$$C(5, 4) \cdot C(5, 4) = 5 \cdot 5 = 25.$$

(b) The student answers 5 questions from section A and 3 questions from section B. The number of ways 8 questions can be answered taking 5 questions from section A and 3 questions from section B are

$$C(5, 5) \cdot C(5, 3) = 1 \cdot 10 = 10.$$

Thus there will be a total of $25 + 10 = 35$ choices.

EXERCISE:

A computer programming team has 14 members.

(a) How many ways can a group of seven be chosen to work on a project?

(b) Suppose eight team members are women and six are men

(i) How many groups of seven can be chosen that contain four women and three men

(ii) How many groups of seven can be chosen that contain at least one man?

(iii) How many groups of seven can be chosen that contain at most three women?

(c) Suppose two team members refuse to work together on projects. How many groups of seven can be chosen to work on a project?

(d) Suppose two team members insist on either working together or not at all on projects.

How many groups of seven can be chosen to work on a project?

(a) How many ways a group of 7 be chosen to work on a project?

SOLUTION:

Number of committees of 7

$$\begin{aligned} C(14, 7) &= \frac{14!}{(14-7)! \cdot 7!} \\ &= \frac{14 \cdot 13 \cdot 12 \cdot 11 \cdot 10 \cdot 9 \cdot 8}{7 \cdot 6 \cdot 5 \cdot 4 \cdot 3 \cdot 2} \\ &= 3432 \end{aligned}$$

(b) Suppose eight team members are women and six are men

(i) How many groups of seven can be chosen that contain four women and three men?

SOLUTION:

Number of groups of seven that contain four women and three men

$$\begin{aligned} C(8, 4) \cdot C(6, 3) &= \frac{8!}{(8-4)! \cdot 4!} \cdot \frac{6!}{(6-3)! \cdot 3!} \\ &= \frac{8 \cdot 7 \cdot 6 \cdot 5}{4!} \cdot \frac{6 \cdot 5 \cdot 4}{3!} \\ &= \frac{8 \cdot 7 \cdot 6 \cdot 5}{4 \cdot 3 \cdot 2} \cdot \frac{6 \cdot 5 \cdot 4}{3 \cdot 2} \\ &= 70 \cdot 20 = 1400 \end{aligned}$$

(b) Suppose eight team members are women and six are men

(ii) How many groups of seven can be chosen that contain at least one man?

SOLUTION:

Total number of groups of seven

$$\begin{aligned} C(14, 7) &= \frac{14!}{(14-7)! \cdot 7!} \\ &= \frac{14 \cdot 13 \cdot 12 \cdot 11 \cdot 10 \cdot 9 \cdot 8}{7 \cdot 6 \cdot 5 \cdot 4 \cdot 3 \cdot 2} \\ &= 3432 \end{aligned}$$

Number of groups of seven that contain no men

$$\begin{aligned} C(8,7) &= \frac{8!}{(8-7)! \cdot 7!} \\ &= 8 \end{aligned}$$

Hence, the number of groups of seven that contain at least one man

$$C(14,7) - C(8,7) = 3432 - 8 = 3424$$

(b) Suppose eight team members are women and six are men

(iii) How many groups of seven can be chosen that contain at most three women?

SOLUTION:

Number of groups of seven that contain no women = 0

$$\begin{aligned} \text{Number of groups of seven that contain one woman} &= C(8,1) \cdot C(6,6) \\ &= 8 \cdot 1 = 8 \end{aligned}$$

$$\begin{aligned} \text{Number of groups of seven that contain two women} &= C(8,2) \cdot C(6,5) \\ &= 28 \cdot 6 = 168 \end{aligned}$$

$$\begin{aligned} \text{Number of groups of seven that contain three women} &= C(8,3) \cdot C(6,4) \\ &= 56 \cdot 15 = 840 \end{aligned}$$

Hence the number of groups of seven that contain at most three women

$$= 0 + 8 + 168 + 840 = 1016$$

(c) Suppose two team members refuse to work together on projects. How many groups of seven can be chosen to work on a project?

SOLUTION:

Call the members who refuse to work together A and B .

Number of groups of seven that contain neither A nor B

$$\begin{aligned} C(12,7) &= \frac{12!}{(12-7)! \cdot 7!} \\ &= 792 \end{aligned}$$

Number of groups of seven that contain A but not B

$$C(12,6) = 924$$

Number of groups of seven that contain B but not A

$$C(12,6) = 924$$

Hence the required number of groups are

$$\begin{aligned} &C(12,7) + C(12,6) + C(12,6) \\ &= 792 + 924 + 924 \\ &= 2640 \end{aligned}$$

(d) Suppose two team members insist on either working together or not at all on projects. How many groups of seven can be chosen to work on a project?

SOLUTION:

Call the members who insist on working together C and D .

Number of groups of seven containing neither C nor D

$$C(12,7) = 792$$

Number of groups of seven that contain both C and D

$$C(12, 5) = 792$$

Hence the required number

$$\begin{aligned} &= C(12, 7) + C(12, 5) \\ &= 792 + 792 = 1584 \end{aligned}$$

EXERCISE:

(a) How many 16-bit strings contain exactly 9 1's?

(b) How many 16-bit strings contain at least one 1?

SOLUTION:

(a) 16-bit strings that contain exactly 9 1's = $C(16, 9) = \frac{16!}{(16-9)!9!} = 11440$

(b) Total no. of 16-bit strings = 2^{16}

Hence number of 16-bit strings that contain at least one 1

$$\begin{aligned} 2^{16} - 1 &= 65536 - 1 \\ &= 65535 \end{aligned}$$

K-SELECTIONS:

k -selections are similar to k -combinations in that the order in which the elements are selected does not matter, but in this case repetitions can occur.

DEFINITION:

A k -selection of a set of n elements is a choice of k elements taken from a set of n elements such that the order of elements does not matter and elements can be repeated.

REMARK:

1. k -selections are also called k -combinations with repetition allowed or multisets of size k .
2. With k -selections of a set of n elements repetition of elements is allowed. Therefore k need not to be less than or equal to n .

THEOREM:

The number of k -selections that can be selected from a set of n elements is

$$C(k+n-1, k) \text{ or } \binom{k+n-1}{k}$$

EXERCISE:

A camera shop stocks ten different types of batteries.

(a) How many ways can a total inventory of 30 batteries be distributed among the ten different types?

(b) Assuming that one of the types of batteries is A76, how many ways can a total inventory of 30 batteries be distributed among the 10 different types if the inventory must include at least four A76 batteries?

SOLUTION:

(a) $k = 30$
 $n = 10$

The required number is

$$\begin{aligned} C(30 + 10 - 1, 30) &= C(39, 30) \\ &= \frac{39!}{(39 - 30)!30!} \end{aligned}$$

$$= 211915132$$

(b) $k = 26$
 $n = 10$

The required number is

$$\begin{aligned} C(26 + 10 - 1, 26) &= C(35, 26) \\ &= \frac{35!}{(35 - 26)!26!} \\ &= 70607460 \end{aligned}$$

WHICH FORMULA TO USE?

	ORDER MATTERS	ORDER DOES NOT MATTER
REPETITION ALLOWED	k-sample n^k	k-selection $C(n+k-1, k)$
REPETITION NOT ALLOWED	k-permutation $P(n, k)$	k-combination $C(n, k)$

Lecture No.32 K-Combinations

ORDERED AND UNORDERED PARTITIONS PERMUTATIONS WITH REPETITIONS

K-SELECTIONS:

k -selections are similar to k -combinations in that the order in which the elements are selected does not matter, but in this case repetitions can occur.

DEFINITION:

A k -selection of a set of n elements is a choice of k elements taken from a set of n elements such that the order of elements does not matter and elements can be repeated.

REMARK:

1. k -selections are also called k -combinations with repetition allowed or multisets of size k .
2. With k -selections of a set of n elements repetition of elements is allowed. Therefore k need not to be less than or equal to n .

THEOREM:

The number of k -selections that can be selected from a set of n elements is

$$C(k+n-1, k) \text{ or } \binom{k+n-1}{k}$$

EXERCISE:

A camera shop stocks ten different types of batteries.

- (a) How many ways can a total inventory of 30 batteries be distributed among the ten different types?
- (b) Assuming that one of the types of batteries is A76, how many ways can a total inventory of 30 batteries be distributed among the 10 different types if the inventory must include at least four A76 batteries?

SOLUTION:

- (a) $k = 30$
 $n = 10$

The required number is

$$\begin{aligned} C(30 + 10 - 1, 30) &= C(39, 30) \\ &= \frac{39!}{(39 - 30)!30!} \\ &= 211915132 \end{aligned}$$

- (b) $k = 26$
 $n = 10$

The required number is

$$\begin{aligned} C(26 + 10 - 1, 26) &= C(35, 26) \\ &= \frac{35!}{(35 - 26)!26!} \end{aligned}$$

$$= 70607460$$

WHICH FORMULA TO USE?

	ORDER MATTERS	ORDER DOES NOT MATTER
REPETITION ALLOWED	k-sample n^k	k-selection $C(n+k-1, k)$
REPETITION NOT ALLOWED	k-permutation $P(n, k)$	k-combination $C(n, k)$

ORDERED AND UNORDERED PARTITIONS:

An unordered partition of a finite set S is a collection $[A_1, A_2, \dots, A_k]$ of disjoint (nonempty) subsets of S (called cells) whose union is S .

The partition is ordered if the order of the cells in the list counts.

EXAMPLE:

$$\text{Let } S = \{1, 2, 3, \dots, 7\}$$

The collections

$$P_1 = [\{1,2\}, \{3,4,5\}, \{6,7\}]$$

$$\text{And } P_2 = [\{6,7\}, \{3,4,5\}, \{1,2\}]$$

determine the same partition of S but are distinct ordered partitions.

EXAMPLE:

Suppose a box B contains seven marbles numbered 1 through 7. Find the number m of ways of drawing from B firstly two marbles, then three marbles and lastly the remaining two marbles.

SOLUTION:

The number of ways of drawing 2 marbles from 7 = $C(7, 2)$

Following this, there are five marbles left in B .

The number of ways of drawing 3 marbles from 5 = $C(5, 3)$

Finally, there are two marbles left in B .

The number of way of drawing 2 marbles from 2 = $C(2, 2)$

Thus

$$\begin{aligned} m &= \binom{7}{2} \binom{5}{3} \binom{2}{2} \\ &= \frac{7!}{2!5!} \cdot \frac{5!}{2!3!} \cdot \frac{2!}{2!0!} \\ &= \frac{7!}{2!3!2!} = 210 \end{aligned}$$

THEOREM:

Let S contain n elements and let n_1, n_2, \dots, n_k be positive integers with

$$n_1 + n_2 + \dots + n_k = n.$$

Then there exist $\frac{n!}{n_1! n_2! n_3! \dots n_k!}$

different ordered partitions of S of the form $[A_1, A_2, \dots, A_k]$, where

A_1 contains n_1 elements

A_2 contains n_2 elements

A_3 contains n_3 elements

.....

A_k contains n_k elements

REMARK:

To find the number of unordered partitions, we have to count the ordered partitions and then divide it by suitable number to erase the order in partitions.

EXERCISE:

Find the number m of ways that nine toys can be divided among four children if the youngest child is to receive three toys and each of the others two toys.

SOLUTION:

We find the number m of ordered partitions of the nine toys into four cells containing 3, 2, 2 and 2 toys respectively.

Hence

$$m = \frac{9!}{3!2!2!2!} = 2520$$

EXERCISE:

How many ways can 12 students be divided into 3 groups with 4 students in each group so that

(i) one group studies English, one History and one Mathematics.

(ii) all the groups study Mathematics.

SOLUTION:

(i) Since each group studies a different subject, so we seek the number of ordered partitions of the 12 students into cells containing 4 students each. Hence there are

$$\frac{12!}{4!4!4!} = 34,650 \quad \text{such partitions}$$

(ii) When all the groups study the same subject, then order doesn't matter.

Now each partition $\{G_1, G_2, G_3\}$ of the students can be arranged in $3!$ ways as an ordered partition, hence there are

$$\frac{12!}{4!4!4!} \times \frac{1}{3!}$$

unordered partitions.

EXERCISE:

How many ways can 8 students be divided into two teams containing

- (i) five and three students respectively.
 (ii) four students each.

SOLUTION:

(i) The two teams (cells) contain different number of students; so the number of unordered partitions equals the number of ordered partitions, which is

$$\frac{8!}{5!3!} = 56$$

(ii) Since the teams are not labeled, so we have to find the number of unordered partitions of 8 students in groups of 4.

Firstly, note, there are $\frac{8!}{4!4!} = 70$ ordered partitions into two cells containing four students each.

Since each unordered partition determine $2! = 2$ ordered partitions, there are

$$\frac{70}{2} = 35$$

unordered partitions

EXERCISE:

Find the number m of ways that a class X with ten students can be partitions into four teams A_1, A_2, B_1 and B_2 where A_1 and A_2 contain two students each and B_1 and B_2 contain three students each.

SOLUTION:

There are $\frac{10!}{2!2!3!3!} = 25,200$ ordered partitions of X into four cells

containing 2, 2, 3 and 3 students respectively.

However, each unordered partition $[A_1, A_2, B_1, B_2]$ of X determines

$2! \cdot 2! = 4$ ordered partitions of X .

Thus,

$$m = \frac{25,200}{4} = 6300$$

EXERCISE:

Suppose 20 people are divided in 6 (numbered) committees so that 3 people each serve on committee C_1 and C_2 , 4 people each on committees C_3 and C_4 , 2 people on committee C_5 and 4 people on committee C_6 . How many possible arrangements are there?

SOLUTION:

We are asked to count labeled group - the committee numbers labeled the group. So this is a problem of ordered partition. Now, the number of ordered partitions of 20 people into the specified committees is

$$\frac{20!}{3!3!4!4!2!4!} = 2444321880000$$

EXERCISE:

If 20 people are divided into teams of size 3, 3, 4, 4, 2, 4, find the number of possible arrangements.

SOLUTION:

Here, we are asked to count unlabeled groups. Accordingly, this is the case of ordered partitions.

$$\begin{aligned}\text{Now number of ordered partitions} &= \frac{20!}{3!3!4!4!2!4!} \times \frac{1}{3!2!} \\ &= 203693490000\end{aligned}$$

GENERALIZED PERMUTATION or PERMUTATIONS WITH REPETITIONS:

The number of permutations of n elements of which n_1 are alike, n_2 are alike, ..., n_k are alike is

$$\frac{n!}{n_1!n_2!\cdots n_k!}$$

REMARK:

The number $\frac{n!}{n_1!n_2!\cdots n_k!}$ is often called a multinomial coefficient, and is denoted by the symbol.

$$\binom{n}{n_1, n_2, \dots, n_k}$$

EXERCISE:

Find the number of distinct permutations that can be formed using the letters of the word "BENZENE".

SOLUTION:

The word "BENZENE" contains seven letters of which three are alike (the 3 E's) and two are alike (the 2 N's)

$$\text{Hence, the number of distinct permutations are: } \frac{7!}{3!2!} = 420$$

EXERCISE:

How many different signals each consisting of six flags hung in a vertical line, can be formed from four identical red flags and two identical blue flags?

SOLUTION:

We seek the number of permutations of 6 elements of which 4 are alike and 2 are alike.

$$\text{There are } \frac{6!}{4!2!} = 15 \quad \text{different signals.}$$

EXERCISE:

(i) Find the number of "**words**" that can be formed of the letters of the word **ELEVEN**.

(ii) Find, if the *words* are to begin with L.

(iii) Find, if the *words* are to begin and end in E.

(iv) Find, if the *words* are to begin with E and end in N.

SOLUTION:

(i) There are six letters of which three are E; hence required number of "*words*" are

$$\frac{6!}{3!} = 120$$

(ii) If the first letter is L, then there are five positions left to fill where three are E; hence required number of words are $\frac{5!}{3!} = 20$

(iii) If the words are to begin and end in E, then there are only four positions to fill with four distinct letters.

Hence required number of words = $4! = 24$

(iv) If the words are to begin with E and end in N, then there are four positions left to fill where two are E.

Hence required number of words = $\frac{4!}{2!} = 12$

EXERCISE:

(i) Find the number of permutations that can be formed from all the letters of the word **BASEBALL**

(ii) Find, if the two B's are to be next to each other.

(iii) Find, if the words are to begin and end in a vowel.

SOLUTION:

(i) There are eight letters of which two are B, two are A, and two are L. Thus,

$$\begin{aligned} \text{Number of permutations} &= \frac{8!}{2!2!2!} \\ &= 5040 \end{aligned}$$

(ii) Consider the two B's as one letter. Then there are seven letters of which two are A and two are L. Hence,

$$\begin{aligned} \text{Number of permutations} &= \frac{7!}{2!2!} \\ &= 1260 \end{aligned}$$

(iii) There are three possibilities, the words begin and end in A, the words begin in A and end in E, or the words begin in E and end in A.

In each case there are six positions left to fill where two are B and two are L. Hence,

$$\text{Number of permutations} = 3 \frac{6!}{2!2!} = 540$$

Lecture No.33 Tree diagram

TREE DIAGRAM INCLUSION - EXCLUSION PRINCIPLE

TREE DIAGRAM:

A tree diagram is a useful tool to list all the logical possibilities of a sequence of events where each event can occur in a finite number of ways.

A tree consists of a root, a number of branches leaving the root, and possible additional branches leaving the end points of other branches. To use trees in counting problems, we use a branch to represent each possible choice. The possible outcomes are represented by the leaves (end points of branches).

A tree is normally constructed from left to right.

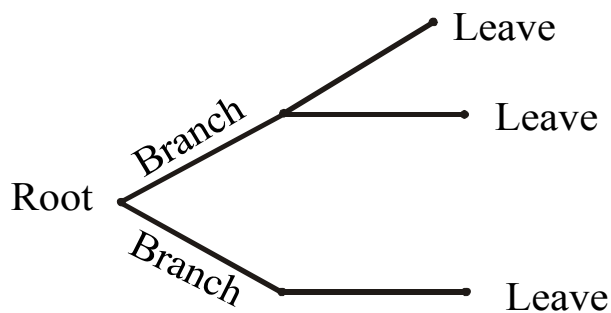

A TREE STRUCTURE

EXAMPLE:

Find the permutations of {a, b, c}

SOLUTION:

The number of permutations of 3 elements is

$$P(3,3) = \frac{3!}{(3-3)!} = 3! = 6$$

We find the six permutations by constructing the appropriate tree diagram. The six permutations are listed on the right of the diagram.

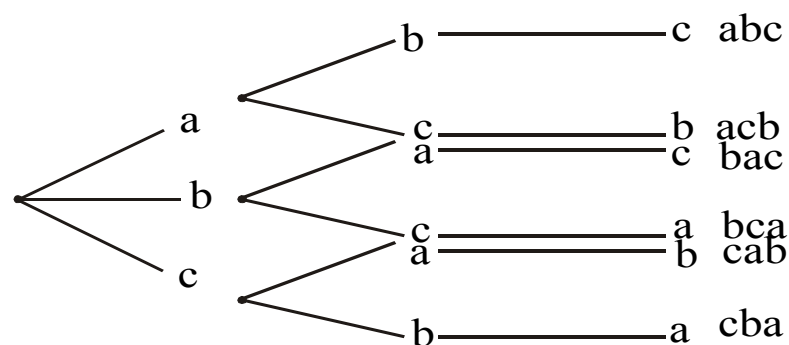

EXERCISE:

Find the product set $A \times B \times C$, where $A = \{1,2\}$, $B = \{a,b,c\}$, and $C = \{3,4\}$ by constructing the appropriate tree diagram.

SOLUTION:

The required diagram is shown next. Each path from the beginning of the tree to the end point designates an element of $A \times B \times C$ which is listed to the right of the tree.

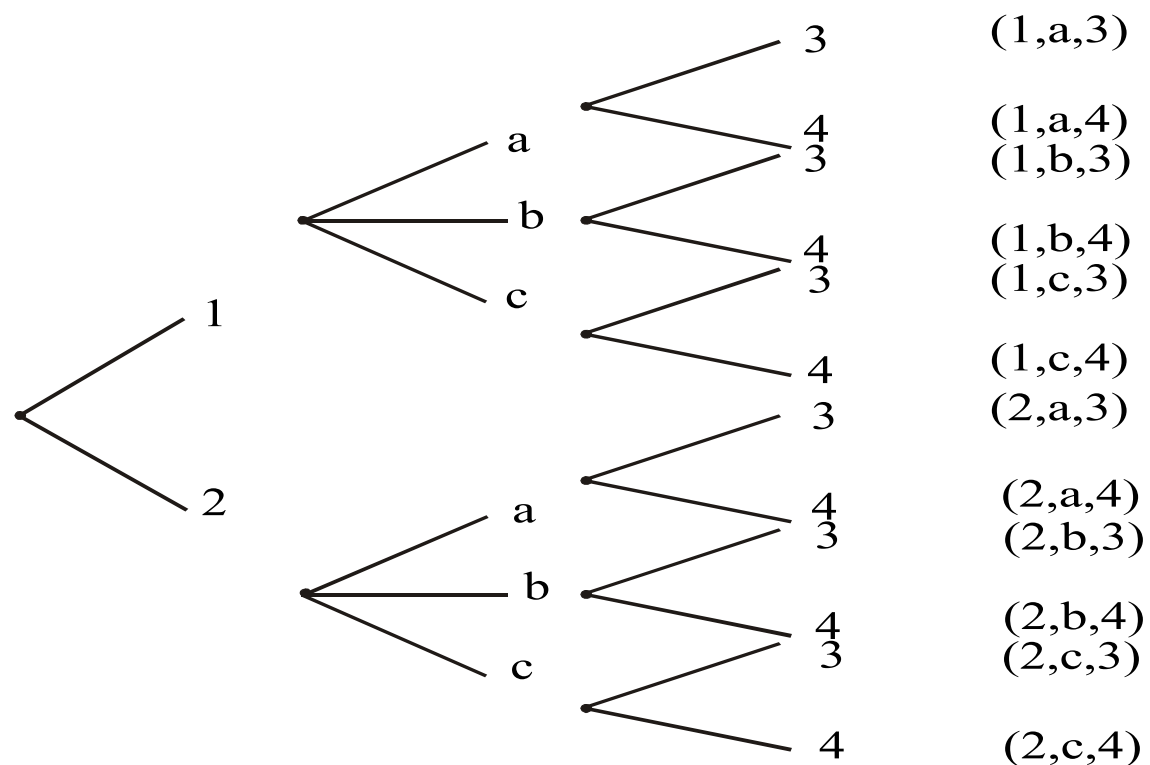
**EXERCISE:**

Teams A and B play in a tournament. The team that first wins two games wins the tournament. Find the number of possible ways in which the tournament can occur.

SOLUTION:

We construct the appropriate tree diagram.

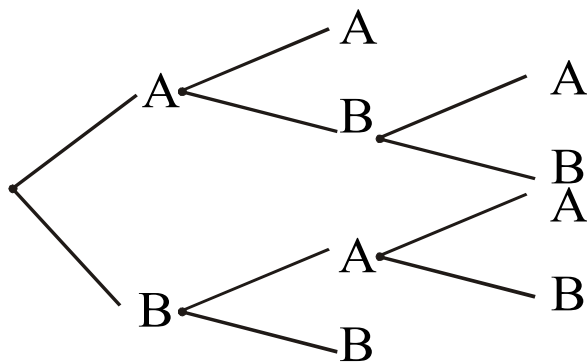

The tournament can occur in 6 ways: AA, ABA, ABB, BAA, BAB, BB

EXERCISE:

How many bit strings of length four do not have two consecutive 1's?

SOLUTION:

The following tree diagrams displays all bit strings of length four without two consecutive 1's. Clearly, there are 8 bit strings.

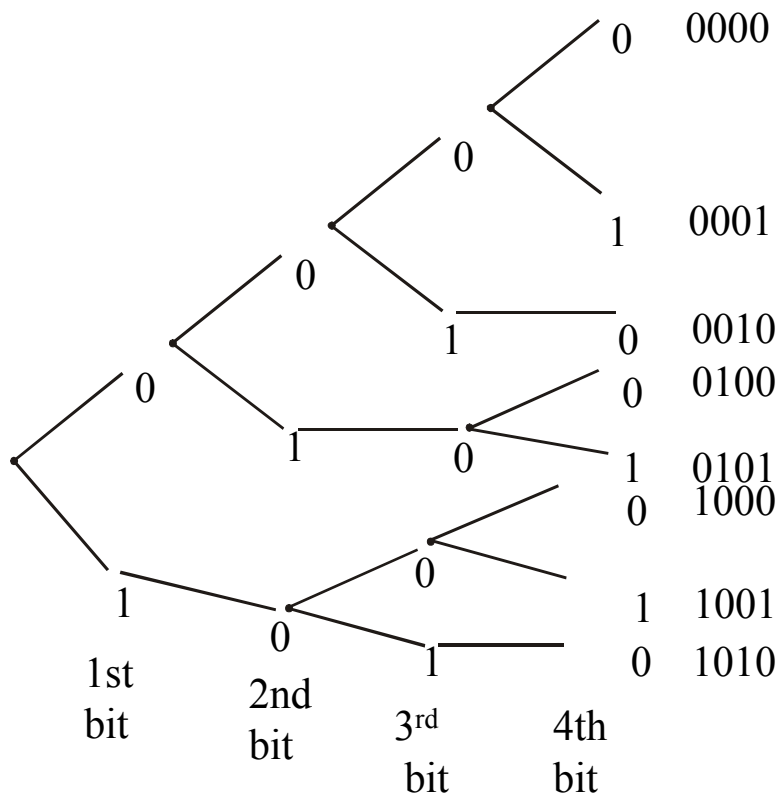

EXERCISE:

Three officers, a president, a treasurer, and a secretary are to be chosen from among four possible: A, B, C and D. Suppose that A cannot be president and either C or D must be secretary.

How many ways can the officers be chosen?

SOLUTION:

We construct the possibility tree to see all the possible choices.

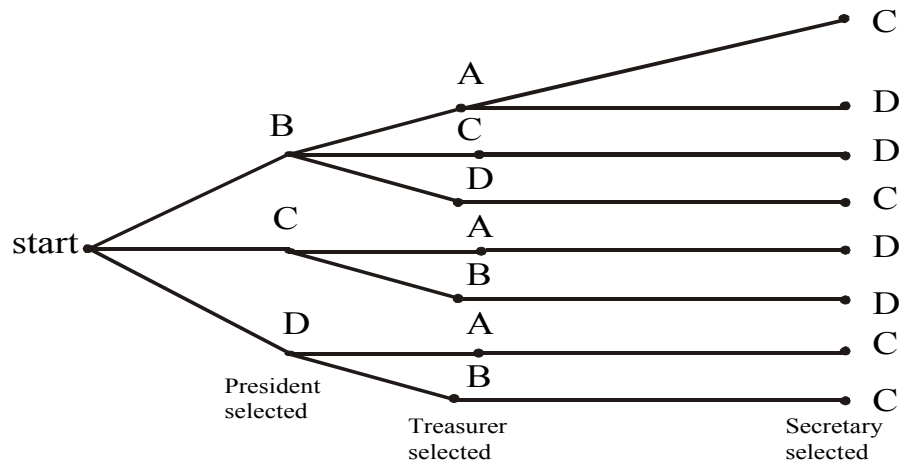

From the tree, see that there are only eight ways possible to choose the officers under given conditions.

THE INCLUSION-EXCLUSION PRINCIPLE:

1. If A and B are disjoint finite sets, then

$$n(A \cup B) = n(A) + n(B)$$

2. If A and B are finite sets, then

$$n(A \cup B) = n(A) + n(B) - n(A \cap B)$$

REMARK:

Statement 1 follows from the sum rule

Statement 2 follows from the diagram

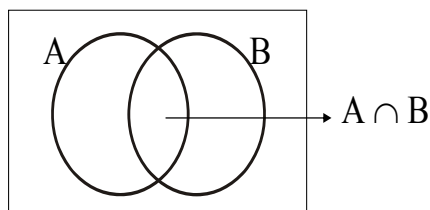

In counting the elements of $A \cup B$, we count the elements in A and count the elements in B.

There are $n(A)$ in A and $n(B)$ in B. However, the elements in $A \cap B$ were counted twice. Thus we subtract $n(A \cap B)$ from $n(A) + n(B)$ to get $n(A \cup B)$.

Hence,

$$n(A \cup B) = n(A) + n(B) - n(A \cap B)$$

EXAMPLE:

There are 15 girls students and 25 boys students in a class. How many students are there in total?

SOLUTION:

Let G be the set of girl students and B be the set of boy students.

Then $n(G) = 15$; $n(B) = 25$

and $n(G \cup B) = ?$

Since, the sets of boy and girl students are disjoint; here total number of students are

$$\begin{aligned} n(G \cup B) &= n(G) + n(B) \\ &= 15 + 25 \\ &= 40 \end{aligned}$$

EXERCISE:

Among 200 people, 150 either swim or jog or both. If 85 swim and 60 swim and jog, how many jog?

SOLUTION:

Let U be the set of people considered. Suppose S be the set of people who swim and J be the set of people who jog. Then given $n(U) = 200$; $n(S \cup J) = 150$

$$n(S) = 85; \quad n(S \cap J) = 60 \quad \text{and} \quad n(J) = ?$$

By inclusion - exclusion principle,

$$n(S \cup J) = n(S) + n(J) - n(S \cap J)$$

$$150 = 85 + n(J) - 60$$

$$\begin{aligned} \Rightarrow \quad n(J) &= 150 - 85 + 60 \\ &= 125 \end{aligned}$$

Hence 125 people jog.

EXERCISE:

Suppose A and B are finite sets. Show that

$$n(A \setminus B) = n(A) - n(A \cap B)$$

SOLUTION:

Set A may be written as the union of two disjoint sets $A \setminus B$ and $A \cap B$.

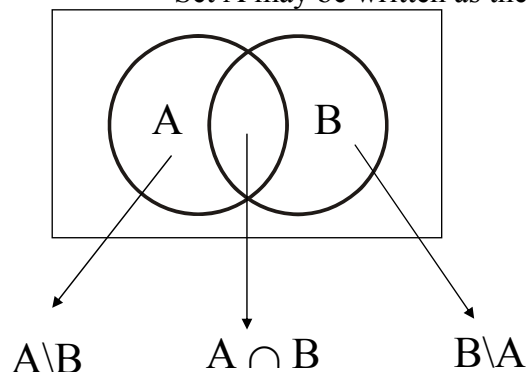

$$\text{i.e., } A = (A \setminus B) \cup (A \cap B)$$

Hence, by inclusion exclusion principle (for disjoint sets)

$$n(A) = n(A \setminus B) + n(A \cap B)$$

$$\Rightarrow n(A \setminus B) = n(A) - n(A \cap B)$$

REMARK:

$$\begin{aligned} n(A') &= n(U \setminus A) && \text{where } U \text{ is the universal set} \\ &= n(U) - n(U \cap A) \\ &= n(U) - n(A) \end{aligned}$$

EXERCISE:

Let A and B be subsets of U with $n(A) = 10$, $n(B) = 15$, $n(A') = 12$, and $n(A \cap B) = 8$. Find $n(A \cup B')$.

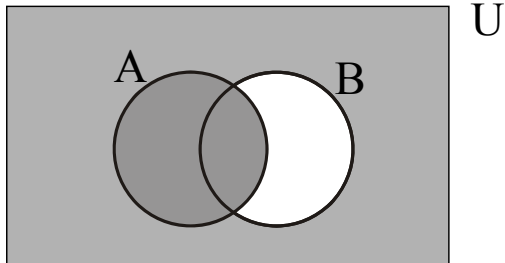
SOLUTION:

From the diagram $A \cup B' = U \setminus (B \setminus A)$

Hence

$$\begin{aligned} n(A \cup B') &= n(U \setminus (B \setminus A)) \\ &= n(U) - n(B \setminus A) \dots\dots\dots(1) \end{aligned}$$

Now $U = A \cup A'$ where A & A' are disjoint sets

$$\begin{aligned} \Rightarrow n(U) &= n(A) + n(A') \\ &= 10 + 12 \\ &= 22 \end{aligned}$$

Also

$$\begin{aligned} n(B \setminus A) &= n(B) - n(A \cap B) \\ &= 15 - 8 \\ &= 7 \end{aligned}$$

Substituting values in (1) we get

$$\begin{aligned} n(A \cup B') &= n(U) - n(B \setminus A) \\ &= 22 - 7 \\ &= 15 \quad \text{Ans.} \end{aligned}$$

EXERCISE:

Let A and B are subset of U with $n(U) = 100$, $n(A) = 50$, $n(B) = 60$, and $n((A \cup B)') = 20$. Find $n(A \cap B)$

SOLUTION:

$$\begin{aligned} &\text{Since } (A \cup B)' = U \setminus (A \cup B) \\ \Rightarrow & n((A \cup B)') = n(U) - n(A \cup B) \\ \Rightarrow & 20 = 100 - n(A \cup B) \end{aligned}$$

$$\Rightarrow n(A \cup B) = 100 - 20 = 80$$

Now, by inclusion - exclusion principle

$$\begin{aligned} n(A \cup B) &= n(A) + n(B) - n(A \cap B) \\ \Rightarrow 80 &= 50 + 60 - n(A \cap B) \\ \Rightarrow n(A \cap B) &= 50 + 60 - 80 = 30 \end{aligned}$$

EXERCISE:

Suppose 18 people read English newspaper (E) or Urdu newspaper (U) or both. Given 5 people read only English newspaper and 7 read both, find the number “r” of people who read only Urdu newspaper.

SOLUTION:

$$\begin{aligned} \text{Given } n(E \cup U) &= 18 \quad n(E \setminus U) = 5, \quad n(E \cap U) = 7 \\ r &= n(U \setminus E) = ? \end{aligned}$$

From the diagram

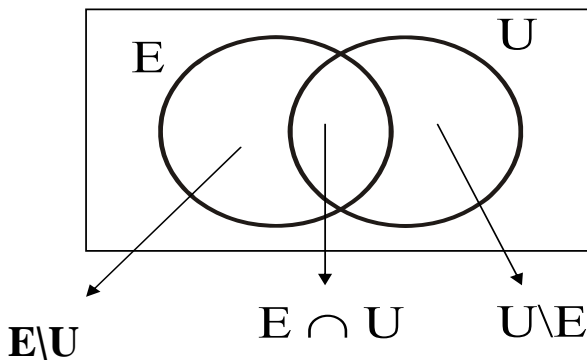

$$\begin{aligned} E \cup U &= (E \setminus U) \cup (E \cap U) \cup (U \setminus E) \\ \text{and the union is disjoint. Therefore,} \\ n(E \cup U) &= n(E \setminus U) + n(E \cap U) + n(U \setminus E) \\ \Rightarrow 18 &= 5 + 7 + r \\ \Rightarrow r &= 18 - 5 - 7 \\ \Rightarrow r &= 6 \quad \text{Ans.} \end{aligned}$$

EXERCISE:

Fifty people are interviewed about their food preferences. 20 of them like Chinese food, 32 like fast food, and 12 like neither Chinese nor fast food. How many like Chinese but not fast food.

SOLUTION:

Let U denote the set of people interviewed and C and F denotes the sets of people who like Chinese food and fast food respectively.

Now given

$$\begin{aligned} n(U) &= 50, & n(C) &= 20 \\ n(F) &= 32, & n((C \cup F)') &= 12 \end{aligned}$$

To find $n(C \cap F') = n(C \setminus F)$

$$\begin{aligned} \text{Since } n((C \cup F)') &= n(U) - n(C \cup F) \\ \Rightarrow 12 &= 50 - n(C \cup F) \end{aligned}$$

$$\Rightarrow n(C \cup F) = 50 - 12 = 38$$

Next

$$\Rightarrow n(C \cup F) = n(C \setminus F) + n(F)$$

$$\Rightarrow 38 = n(C \setminus F) + 32$$

$$\Rightarrow n(C \setminus F) = 38 - 32 = 6$$

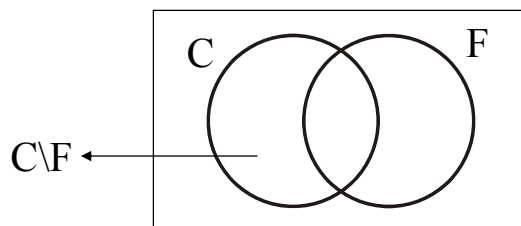

Lecture No.34 Inclusion-exclusion principle

INCLUSION-EXCLUSION PRINCIPLE PIGEONHOLE PRINCIPLE

EXERCISE:

- a. How many integers from 1 through 1000 are multiples of 3 or multiples of 5?
b. How many integers from 1 through 1000 are neither multiples of 3 nor multiples of 5?

SOLUTION:

(a) Let A and B denote the set of integers from 1 through 1000 that are multiples of 3 and 5 respectively.

Then $A \cap B$ contains integers that are multiples of 3 and 5 both i.e., multiples of 15.

Now

$$n(A) = \left[\begin{matrix} 1000 \\ 3 \end{matrix} \right] = 333 \quad \text{and} \quad n(B) = \left[\begin{matrix} 1000 \\ 5 \end{matrix} \right] = 200$$

and

$$n(A \cap B) = \left[\begin{matrix} 1000 \\ 15 \end{matrix} \right] = 66$$

Hence by the inclusion - exclusion principle

$$\begin{aligned} n(A \cup B) &= n(A) + n(B) - n(A \cap B) \\ &= 333 + 200 - 66 \\ &= 467 \end{aligned}$$

(b) The set $(A \cup B)'$ contains those integers that are either multiples of 3 or multiples of 5.

Now

$$\begin{aligned} n((A \cup B)') &= n(U) - n(A \cup B) \\ &= 1000 - 467 \\ &= 533 \end{aligned}$$

where the universal set U contains integers 1 through 1000.

INCLUSION-EXCLUSION PRINCIPLE FOR 3 AND 4 SETS:

If A, B, C and D are finite sets, then

$$1. n(A \cup B \cup C) = n(A) + n(B) + n(C) - n(A \cap B) - n(B \cap C) - n(A \cap C) + n(A \cap B \cap C)$$

$$\begin{aligned} 2. n(A \cup B \cup C \cup D) &= n(A) + n(B) + n(C) + n(D) - n(A \cap B) - n(A \cap C) - n(A \cap D) \\ &\quad - n(B \cap C) - n(B \cap D) - n(C \cap D) + n(A \cap B \cap C) + n(A \cap B \cap D) \\ &\quad + n(A \cap C \cap D) + n(B \cap C \cap D) - n(A \cap B \cap C \cap D) \end{aligned}$$

EXERCISE:

A survey of 100 college students gave the following data:

8 owned a car (C)

20 owned a motorcycle (M)

48 owned a bicycle (B)

38 owned neither a car nor a motorcycle nor a bicycle

No student who owned a car, owned a motorcycle

How many students owned a bicycle and either a car or a motorcycle?

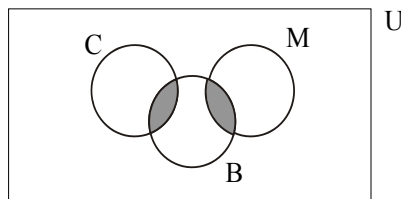
SOLUTION:

No. of elements in the shaded region to be determined

Let U represents the universal set of 100 college students. Now given that

$$n(U) = 100; \quad n(C) = 8$$

$$n(M) = 20; \quad n(B) = 48$$

$$n((C \cup M \cup B)') = 38; \quad n(C \cap M) = 0$$

$$\text{and } n(B \cap C) + n(B \cap M) = ?$$

Firstly note $n((C \cup M \cup B)') = n(U) - n(C \cup M \cup B)$

$$\Rightarrow 38 = 100 - n(C \cup M \cup B)$$

$$\Rightarrow n(C \cup M \cup B) = 100 - 38 = 62$$

Now by inclusion - exclusion principle

$$n(C \cup M \cup B) = n(C) + n(M) + n(B) - n(C \cap M) - n(C \cap B) - n(M \cap B) + n(C \cap M \cap B)$$

$$\Rightarrow 62 = 8 + 20 + 48 - 0 - n(C \cap B) - n(M \cap B) - 0$$

$$(\therefore n(C \cap B) = 0)$$

$$\Rightarrow n(C \cap B) + n(M \cap B) = 8 + 20 + 48 - 62$$

$$= 76 - 62$$

$$= 14$$

Hence, there are 14 students, who owned a bicycle and either a car or a motorcycle.

REVISION OF FUNCTIONS:

not a function

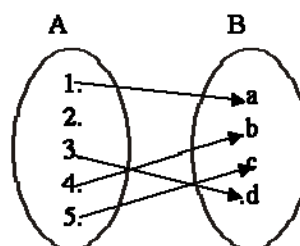

Clearly the above relation is not a function because 2 does not have any image under this relation. Note that if want to made it relation we have to must map the 2 into some element of B which is also the image of some element of A. Now

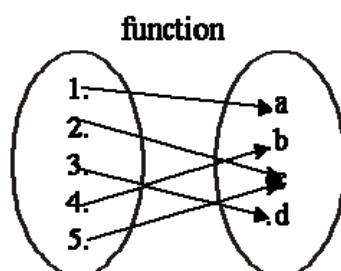

the above relation is a function because it satisfy the conditions of functions(as each element of 1st set have the images in 2nd set). The following is a function.

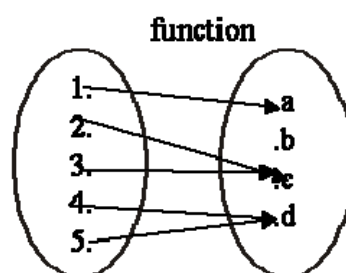

The above relation is a function because it satisfy the conditions of functions(as each element of 1st set have the images in 2nd set). Therefore the above is also a function.

PIGEONHOLE PRINCIPLE:

A function from a set of $k + 1$ or more elements to a set of k elements must have at least two elements in the domain that have the same image in the co-domain.

If $k + 1$ or more pigeons fly into k pigeonholes then at least one pigeonhole must contain two or more pigeons.

EXAMPLES:

1. Among any group of 367 people, there must be at least two with the same birthday, because there are only 366 possible birthdays.
2. In any set of 27 English words, there must be at least two that begin with the same letter, since there are 26 letters in the English alphabet.

EXERCISE:

What is the minimum number of students in a class to be sure that two of them are born in the same month?

SOLUTION:

There are 12 ($= n$) months in a year. The pigeonhole principle shows that among any 13 ($= n + 1$) or more students there must be at least two students who are born in the same month.

EXERCISE:

Given any set of seven integers, must there be two that have the same remainder when divided by 6?

SOLUTION:

The set of possible remainders that can be obtained when an integer is divided by six is $\{0, 1, 2, 3, 4, 5\}$. This set has 6 elements. Thus by the pigeonhole principle if $7 = 6 + 1$ integers are each divided by six, then at least two of them must have the same remainder.

EXERCISE:

How many integers from 1 through 100 must you pick in order to be sure of getting one that is divisible by 5?

SOLUTION:

There are 20 integers from 1 through 100 that are divisible by 5. Hence there are eighty integers from 1 through 100 that are not divisible by 5. Thus by the pigeonhole principle $81 = 80 + 1$ integers from 1 through 100 must be picked in order to be sure of getting one that is divisible by 5.

EXERCISE:

Let $A = \{1, 2, 3, 4, 5, 6, 7, 8, 9, 10\}$. Suppose six integers are chosen from A . Must there be two integers whose sum is 11.

SOLUTION:

The set A can be partitioned into five subsets:

$\{1, 10\}$, $\{2, 9\}$, $\{3, 8\}$, $\{4, 7\}$, and $\{5, 6\}$

each consisting of two integers whose sum is 11.

These 5 subsets can be considered as 5 pigeonholes.

If $6 = (5 + 1)$ integers are selected from A , then by the pigeonhole principle at least two must be from one of the five subsets. But then the sum of these two integers is 11.

GENERALIZED PIGEONHOLE PRINCIPLE:

A function from a set of $n \cdot k + 1$ or more elements to a set of n elements must have at least $k + 1$ elements in the domain that have the same image in the co-domain.

If $n \cdot k + 1$ or more pigeons fly into n pigeonholes then at least one pigeonhole must contain $k + 1$ or more pigeons.

EXERCISE:

Suppose a laundry bag contains many red, white, and blue socks. Find the minimum number of socks that one needs to choose in order to get two pairs (four socks) of the same colour.

SOLUTION:

Here there are $n = 3$ colours (pigeonholes) and $k + 1 = 4$ or $k = 3$. Thus among any $n \cdot k + 1 = 3 \cdot 3 + 1 = 10$ socks (pigeons), at least four have the same colour.

DEFINITION:

1. Given any real number x , **the floor of x** , denoted $\lfloor x \rfloor$, is the largest integer smaller than or equal to x .

2. Given any real number x , **the ceiling of x** , denoted $\lceil x \rceil$, is the smallest integer greater than or equal to x .

EXAMPLE:

Compute $\lfloor x \rfloor$ and $\lceil x \rceil$ for each of the following values of x .

- a. $25/4$ b. 0.999 c. -2.01

SOLUTION:

a. $\lfloor 25/4 \rfloor = \lfloor 6 + 1/4 \rfloor = 6$
 $\lceil 25/4 \rceil = \lceil 6 + 1/4 \rceil = 6 + 1 = 7$

b. $\lfloor 0.999 \rfloor = \lfloor 0 + 0.999 \rfloor = 0$
 $\lceil 0.999 \rceil = \lceil 0 + 0.999 \rceil = 0 + 1 = 1$

c. $\lfloor -2.01 \rfloor = \lfloor -3 + 0.99 \rfloor = -3$
 $\lceil -2.01 \rceil = \lceil -3 + 0.999 \rceil = -3 + 1 = -2$

EXERCISE:

What is the smallest integer N such that

- a. $\lceil N/7 \rceil = 5$ b. $\lceil N/9 \rceil = 6$

SOLUTION:

a. $N = 7 \cdot (5 - 1) + 1 = 7 \cdot 4 + 1 = 29$

b. $N = 9 \cdot (6 - 1) + 1 = 9 \cdot 5 + 1 = 46$

PIGEONHOLE PRINCIPLE:

If N pigeons fly into k pigeonholes then at least one pigeonhole must contain $\lceil N/k \rceil$ or more pigeons.

EXAMPLE:

Among 100 people there are at least $\lceil 100/12 \rceil = \lceil 8 + 1/3 \rceil = 9$ who were born in the same month.

EXERCISE:

What is the minimum number of students required in a Discrete Mathematics class to be sure that at least six will receive the same grade, if there are five possible grades, A, B, C, D, and F.

SOLUTION:

The minimum number of students needed to guarantee that at least six students receive the same grade is the smallest integer N such that $\lceil N/5 \rceil = 6$.

The smallest such integer is $N = 5(6-1)+1=5 \cdot 5 + 1 = 26$.

Thus 26 is the minimum number of students needed to be sure that at least 6 students will receive the same grades.

Lecture No.35 Probability

INTRODUCTION TO PROBABILITY

INTRODUCTION:

Combinatorics and probability theory share common origins. The theory of probability was first developed in the seventeenth century when certain gambling games were analyzed by the French mathematician Blaise Pascal. It was in these studies that Pascal discovered various properties of the binomial coefficients. In the eighteenth century, the French mathematician Laplace, who also studied gambling, gave definition of the probability as the number of successful outcomes divided by the number of total outcomes.

DEFINITIONS:

An **experiment** is a procedure that yields a given set of possible outcomes.

The **sample space** of the experiment is the set of possible outcomes.

An **event** is a subset of the sample space.

EXAMPLE:

When a die is tossed the sample space S of the experiment have the following six outcomes. $S = \{1, 2, 3, 4, 5, 6\}$

Let E_1 be the event that a 6 occurs,

E_2 be the event that an even number occurs,

E_3 be the event that an odd number occurs,

E_4 be the event that a prime number occurs,

E_5 be the event that a number less than 5 occurs, and

E_6 be the event that a number greater than 6 occurs.

Then

$$E_1 = \{6\} \qquad E_2 = \{2, 4, 6\}$$

$$E_3 = \{1, 3, 5\} \qquad E_4 = \{2, 3, 5\}$$

$$E_5 = \{1, 2, 3, 4\} \qquad E_6 = \Phi$$

EXAMPLE:

When a pair of dice is tossed, the sample space S of the experiment has the following thirty-six outcomes

$$S = \{(1, 1), (1, 2), (1, 3), (1, 4), (1, 5), (1, 6) \\ (2, 1), (2, 2), (2, 3), (2, 4), (2, 5), (2, 6) \\ (3, 1), (3, 2), (3, 3), (3, 4), (3, 5), (3, 6) \\ (4, 1), (4, 2), (4, 3), (4, 4), (4, 5), (4, 6) \\ (5, 1), (5, 2), (5, 3), (5, 4), (5, 5), (5, 6) \\ (6, 1), (6, 2), (6, 3), (6, 4), (6, 5), (6, 6)\}$$

or more compactly,

$$\{11, 12, 13, 14, 15, 16, 21, 22, 23, 24, 25, 26, \\ 31, 32, 33, 34, 35, 36, 41, 42, 43, 44, 45, 46\}$$

51, 52, 53, 54, 55, 56, 61, 62, 63, 64, 65, 66}

Let E be the event in which the sum of the numbers is ten.

Then

$$E = \{(4, 6), (5, 5), (6, 4)\}$$

DEFINITION:

Let S be a finite sample space such that all the outcomes are equally likely to occur.

The **probability** of an event E , which is a subset of sample space S , is

$$P(E) = \frac{\text{the number of outcomes in } E}{\text{the number of total outcomes in } S} = \frac{n(E)}{n(S)}$$

REMARK:

Since $\Phi \subseteq E \subseteq S$ therefore, $0 \leq n(E) \leq n(S)$. It follows that the probability of an event is always between 0 and 1.

EXAMPLE:

What is the probability of getting a number greater than 4 when a dice is tossed?

SOLUTION:

When a dice is rolled its sample space is $S = \{1, 2, 3, 4, 5, 6\}$

Let E be the event that a number greater than 4 occurs. Then $E = \{5, 6\}$

Hence,

$$P(E) = \frac{n(E)}{n(S)} = \frac{2}{6} = \frac{1}{3}$$

EXAMPLE:

What is the probability of getting a total of eight or nine when a pair of dice is tossed?

SOLUTION:

When a pair of dice is tossed, its sample space S has the 36 outcomes which are as follows:

$$S = \{(1, 1), (1, 2), (1, 3), (1, 4), (1, 5), (1, 6) \\ (2, 1), (2, 2), (2, 3), (2, 4), (2, 5), (2, 6) \\ (3, 1), (3, 2), (3, 3), (3, 4), (3, 5), (3, 6) \\ (4, 1), (4, 2), (4, 3), (4, 4), (4, 5), (4, 6) \\ (5, 1), (5, 2), (5, 3), (5, 4), (5, 5), (5, 6) \\ (6, 1), (6, 2), (6, 3), (6, 4), (6, 5), (6, 6)\}$$

Let E be the event that the sum of the numbers is eight or nine. Then

$$E = \{(2, 6), (3, 5), (4, 4), (5, 3), (6, 2), (3, 6), (4, 5), (5, 4), (6, 3)\}$$

Hence,

$$P(E) = \frac{n(E)}{n(S)} = \frac{9}{36} = \frac{1}{4}$$

EXAMPLE:

An urn contains four red and five blue balls. What is the probability that a ball chosen from the urn is blue?

SOLUTION:

Since there are four red balls and five blue balls so if we take out one ball from the urn then there is possibility that it may be one of from four red and one of from five blue balls hence there are total of nine possibilities. Thus we have

The total number of possible outcomes = $4 + 5 = 9$

Now our favourable event is that we get the blue ball when we choose a ball from the urn. So we have

The total number of favorable outcomes = 5

Now we have Favorable outcomes 5 and our sample space has total outcomes 9. Thus we have

The probability that a ball chosen = $5/9$

EXERCISE:

Two cards are drawn at random from an ordinary pack of 52 cards. Find the probability p that (i) both are spades, (ii) one is a spade and one is a heart.

SOLUTION:

There are $\binom{52}{2} = 1326$ ways to draw 2 cards from 52 card

(i) There are $\binom{13}{2} = 78$ ways to draw 2 spades from 13 spades (as spades are 13 in 52 cards); hence

$$p = \frac{\text{number of ways 2 spades can be drawn}}{\text{number of ways 2 cards can be drawn}} = \frac{78}{1326} = \frac{1}{17}$$

ii) Since there are 13 spades and 13 hearts, there are $\binom{13}{1} \binom{13}{1} = 13 \cdot 13 = 169$ ways to draw

a spade and a heart; hence $p = \frac{169}{1326} = \frac{13}{102}$

EXAMPLE:

In a lottery, players win the first prize when they pick three digits that match, in the correct order, three digits kept secret. A second prize is won if only two digits match. What is the probability of winning (a) the first prize, (b) the second prize?

SOLUTION:

Using the product rule, there are $10^3 = 1000$ ways to choose three digits.

(a) There is only one way to choose all three digits correctly. Hence the probability that a player wins the first prize is $1/1000 = 0.001$.

(b) There are three possible cases:

(i) The first digit is incorrect and the other two digits are correct

(ii) The second digit is incorrect and the other two digits are correct

(iii) The third digit is incorrect and the other digits are correct

To count the number of successes with the first digit incorrect, note that there are nine choices for the first digit to be incorrect, and one each for the other two digits to be correct. Hence, there are nine ways to choose three digits where the first digit is incorrect, but the other two are correct. Similarly, there are nine ways for the other two cases. Hence, there are $9 + 9 + 9 = 27$ ways to choose three digits with two of the three digits correct.

It follows that the probability that a player wins the second prize is $27/1000 = 0.027$.

EXAMPLE:

What is the probability that a hand of five cards contains four cards of one kind?

SOLUTION:

(i) For determining the favorable outcomes we note that

The number of ways to pick one kind = $C(13, 1)$

The number of ways to pick the four of this kind out of the four of this kind in the deck = $C(4, 4)$

The number of ways to pick the fifth card from the remaining 48 cards = $C(48, 1)$

Hence, using the product rule the number of hands of five cards with four cards of one kind = $C(13, 1) \times C(4, 4) \times C(48, 1)$

(ii) The total number of different hands of five cards = $C(52, 5)$.

From (i) and (ii) it follows that the probability that a hand of five cards contains four cards of one kind is

$$\frac{C(13,1) \cdot C(4,4) \cdot C(48,1)}{C(52,5)} = \frac{13 \cdot 1 \cdot 48}{2,598,960} \approx 0.0024$$

EXAMPLE:

Find the probability that a hand of five cards contains three cards of one kind and two of another kind.

SOLUTION:

(i) For determining the favorable outcomes we note that

The number of ways to pick two kinds = $C(13, 2)$

The number of ways to pick three out four of the first kind = $C(4, 3)$

The number of ways to pick two out four of the second kind = $C(4, 2)$

Hence, using the product rule the number of hands of five cards with three cards of one kind and two of another kind = $C(13, 2) \times C(4, 3) \times C(4, 2)$

(ii) The total number of different hands of five cards = $C(52, 5)$.

From (i) and (ii) it follows that the probability that a hand of five cards contains three cards of one kind and two of another kind is

$$\frac{C(13,2) \cdot C(4,3) \cdot C(4,2)}{C(52,5)} = \frac{3744}{2,598,960} \approx 0.0014$$

EXAMPLE:

What is the probability that a randomly chosen positive two-digit number is a multiple of 6?

SOLUTION:

1. There are $\lfloor 99/6 \rfloor = \lfloor 16 + \frac{1}{2} \rfloor = 16$ positive integers from 1 to 99 that are divisible by 6. Out of these $16 - 1 = 15$ are two-digit numbers (as 6 is a multiple of 6 but not a two-digit number).

2. There are $99 - 9 = 90$ positive two-digit numbers in all.

Hence, the probability that a randomly chosen positive two-digit number is a multiple of 6 is

$$= 15/90 = 1/6 \approx 0.166667$$

DEFINITION:

Let E be an event in a sample space S , the complement of E is the event that occurs if E does not occur. It is denoted by E^c . Note that $E^c = S \setminus E$

EXAMPLE:

Let E be the event that an even number occurs when a die is tossed. Then E^c is the event that an odd number occurs.

THEOREM:

Let E be an event in a sample space S . The probability of the complementary event E^c of E is given by

$$P(E^c) = 1 - P(E).$$

EXAMPLE:

Let 2 items be chosen at random from a lot containing 12 items of which 4 are defective. What is the probability that (i) none of the items chosen are defective, (ii) at least one item is defective?

SOLUTION:

The number of ways 2 items can be chosen from 12 items = $C(12, 2) = 66$.

(i) Let A be the event that none of the items chosen are defective.

The number of favorable outcomes for A = The number of ways 2 items can be chosen from 8 non-defective items = $C(8, 2) = 28$.

Hence, $P(A) = 28/66 = 14/33$.

(ii) Let B be the event that at least one item chosen is defective.

Then clearly, $B = A^c$

It follows that

$$P(B) = P(A^c) \\ = 1 - P(A) = 1 - 14/33 = 19/33.$$

EXERCISE:

Three light bulbs are chosen at random from 15 bulbs of which 5 are defective. Find the probability p that (i) none is defective, (ii) exactly one is defective, (iii) at least one is defective.

SOLUTION:

There are $\binom{15}{3} = 455$ ways to choose 3 bulbs from the 15 bulbs.

(i) Since there are $15 - 5 = 10$ non-defective bulbs, there are $\binom{10}{3} = 120$ ways to choose 3 non-defective bulbs.

Thus

$$p = \frac{120}{455} = \frac{24}{91}$$

(ii) There are 5 defective bulbs and $\binom{10}{2} = 45$ different pairs of non-defective bulbs;

hence there are $\binom{5}{1} \binom{10}{2} = 5 \cdot 45 = 225$ ways to choose 3 bulbs of which one is defective.

Thus

$$P = \frac{225}{455} = \frac{45}{91}.$$

(iii) The event that at least one is defective is the complement of the event that none are defective which has by (i), probability $\frac{24}{91}$.

$$\text{Hence } p(\text{at least one is defective}) = 1 - p(\text{none is defective}) = 1 - \frac{24}{91} = \frac{67}{91}$$

Lecture No.36 Laws of probability

ADDITION LAW OF PROBABILITY

THEOREM:

If A and B are two disjoint (mutually exclusive) events of a sample space S, then

$$P(A \cup B) = P(A) + P(B)$$

In words, the probability of the happening of an event A or an event B or both is equal to the sum of the probabilities of event A and event B provided the events have nothing in common.

PROOF:

By inclusion - exclusion principle for mutually disjoint sets,

$$n(A \cup B) = n(A) + n(B)$$

Dividing both sides by n(S), we get

$$\begin{aligned} \frac{n(A \cup B)}{n(S)} &= \frac{n(A) + n(B)}{n(S)} \\ &= \frac{n(A)}{n(S)} + \frac{n(B)}{n(S)} \end{aligned}$$

$$\Rightarrow P(A \cup B) = P(A) + P(B)$$

EXAMPLE:

Suppose a die is rolled. Let A be the event that 1 appears & B be the event that some even number appears on the die. Then

$$S = \{1, 2, 3, 4, 5, 6\}, \quad A = \{1\} \quad \& \quad B = \{2, 4, 6\}$$

Clearly A & B are disjoint events and

$$P(A) = \frac{1}{6}, \quad P(B) = \frac{3}{6}$$

Hence the probability that a 1 appears or some even number appears is given by

$$\begin{aligned} P(A \cup B) &= P(A) + P(B) \\ &= \frac{1}{6} + \frac{3}{6} \\ &= \frac{4}{6} = \frac{2}{3} \quad \text{Ans.} \end{aligned}$$

EXERCISE:

A bag contains 6 white, 5 black and 4 red balls. Find the probability of getting a white or a black ball in a single draw.

SOLUTION:

Let A be the event of getting a white ball and B be the event of getting a black ball.

Total number of balls = $6 + 5 + 4 = 15$

Since the two events are disjoint (mutually exclusive), therefore

$$P(A) = \frac{6}{15}, \quad P(B) = \frac{5}{15}$$

$$\begin{aligned} P(A \cup B) &= P(A) + P(B) \\ &= \frac{6}{15} + \frac{5}{15} \\ &= \frac{11}{15} \end{aligned} \quad \text{Ans}$$

EXERCISE:

A pair of dice is thrown. Find the probability of getting a total of 5 or 11.

SOLUTION:

When two dice are thrown, the sample space has $6 * 6 = 36$ outcomes. Let A be the event that a total of 5 occurs and B be the event that a total of 11 occurs.

Then

$$A = \{(1,4), (2,3), (3,2), (4,1)\} \text{ and } B = \{(5,6), (6,5)\}$$

Clearly, the events A and B are disjoint (mutually exclusive) with probabilities given by

Now by using the sum Rule for Mutually Exclusive events we get

$$\begin{aligned} P(A \cup B) &= P(A) + P(B) \\ &= \frac{4}{36} + \frac{2}{36} = \frac{6}{36} = \frac{1}{6} \end{aligned} \quad \text{Ans}$$

EXERCISE:

For any two event A and B of a sample space S. Prove that

$$P(A \setminus B) = P(A \cap B') = P(A) - P(A \cap B)$$

SOLUTION:

The event A can be written as the union of two disjoint events $A \setminus B$ and $A \cap B$. i.e. $A = (A \setminus B) \cup (A \cap B)$

Hence, by addition law of probability

$$P(A) = P(A \setminus B) + P(A \cap B)$$

$$\Rightarrow P(A \setminus B) = P(A) - P(A \cap B)$$

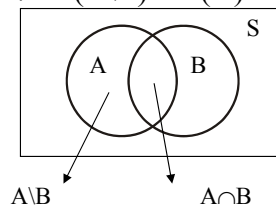

GENERAL ADDITION LAW OF PROBABILITY

THEOREM

If A and B are any two events of a sample space S, then

$$P(A \cup B) = P(A) + P(B) - P(A \cap B)$$

PROOF:

The event $A \cup B$ may be written as the union of two disjoint events $A \setminus B$ and B.

$$\text{i.e., } A \cup B = (A \setminus B) \cup B$$

Hence, by addition law of probability (for disjoint events)

$$\begin{aligned} P(A \cup B) &= P(A \setminus B) + P(B) \\ &= [P(A) - P(A \cap B)] + P(B) \\ &= P(A) + P(B) - P(A \cap B) \quad \text{(proved)} \end{aligned}$$

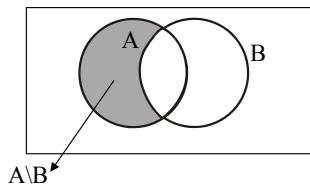

REMARK:

By inclusion - exclusion principle

$$n(A \cup B) = n(A) + n(B) - n(A \cap B) \quad (\text{where } A \text{ and } B \text{ are finite})$$

Dividing both sides by $n(S)$ and denoting the ratios as respective probabilities we get the Generalized Addition Law of probability.

$$\text{i.e } P(A \cup B) = P(A) + P(B) - P(A \cap B)$$

EXERCISE:

Let A and B be events in a sample space S, and let

$$P(A) = 0.65, P(B) = 0.30 \text{ and } P(A \cap B) = 0.15$$

Determine the probability of the events

$$(a) A \cap B' \quad (b) A \cup B \quad (c) A' \cap B'$$

SOLUTION:

(a) As we know that

$$\begin{aligned} P(A \cap B') &= P(A) - P(A \cap B) \quad (\text{as } A - B = A \cap B') \\ &= 0.65 - 0.15 \\ &= 0.50 \end{aligned}$$

(b) By addition Law of probability

$$\begin{aligned} P(A \cup B) &= P(A) + P(B) - P(A \cap B) \quad (\text{as } A \cap B \neq \emptyset) \\ &= 0.65 + 0.30 - 0.15 \\ &= 0.80 \end{aligned}$$

(c) By DeMorgan's Law

$$\begin{aligned} A' \cap B' &= (A \cup B)' \\ \therefore P(A' \cap B') &= P(A \cup B)' \\ &= 1 - P(A \cup B) \end{aligned}$$

$$= 1 - 0.80$$

$$= 0.20 \quad \text{Ans.}$$

EXERCISE:

Let A, B, C and D be events which form a partition of a sample space S. If $P(A) = P(B)$, $P(C) = 2 P(A)$ and $P(D) = 2 P(C)$. Determine each of the following probabilities.

(a) $P(A)$ (b) $P(A \cup B)$ (c) $P(A \cup C \cup D)$

SOLUTION:

(a) Since A, B, C and D form a partition of S, therefore

$S = A \cup B \cup C \cup D$ and A, B, C, D are pair wise disjoint. Hence, by addition law of probability.

$$P(S) = P(A) + P(B) + P(C) + P(D)$$

$$\Rightarrow 1 = P(A) + P(A) + 2P(A) + 2P(C)$$

$$\Rightarrow 1 = 4P(A) + 2(2P(A))$$

$$\Rightarrow 1 = 8P(A)$$

$$\Rightarrow P(A) = \frac{1}{8}$$

(b) $P(A \cup B) = P(A) + P(B)$

$$= P(A) + P(A) \quad [\because P(B) = P(A)]$$

$$= 2P(A)$$

$$= 2 \left(\frac{1}{8} \right) = \frac{1}{4}$$

(c) $P(A \cup C \cup D) = P(A) + P(C) + P(D)$

$$= P(A) + 2P(A) + 2(2P(A)) \quad [\because P(C) = 2P(A) \text{ \& } P(D) = 2P(C)]$$

$$= 7P(A)$$

$$= 7 \left(\frac{1}{8} \right) = \frac{7}{8} \quad \text{Ans.}$$

EXERCISE:

A card is drawn from a well-shuffled pack of playing card. What is the probability that it is either a spade or an ace?

SOLUTION:

Let A be the event of drawing a spade and B be the event of drawing an ace. Now A and B are not disjoint events. $A \cap B$ represents the event of drawing an ace of spades.

Now

$$\begin{aligned}
 P(A) &= \frac{13}{52}; & P(B) &= \frac{4}{52} \\
 P(A \cap B) &= \frac{1}{52} \\
 \therefore P(A \cup B) &= P(A) + P(B) - P(A \cap B) \\
 &= \frac{13}{52} + \frac{4}{52} - \frac{1}{52} \\
 &= \frac{16}{52} = \frac{4}{13}
 \end{aligned}$$

EXERCISE:

A class contains 10 boys and 20 girls of which half the boys and half the girls have brown eyes. Find the probability that a student chosen at random is a boy or has brown eyes.

SOLUTION:

Let A be the event that a boy is chosen and B be the event that a student with brown eyes is chosen. Then A and B are not disjoint events. Infact, $A \cap B$ represents the event that a boy with brown eyes is chosen.

$$P(A) = \frac{10}{10+20} = \frac{10}{30}$$

$$P(B) = \frac{5+10}{10+20} = \frac{15}{30}$$

and

$$P(A \cap B) = \frac{5}{10+20} = \frac{5}{30} \text{ (as some boys also have brown eyes)}$$

$$\begin{aligned}
 \therefore P(A \cup B) &= P(A) + P(B) - P(A \cap B) \\
 &= \frac{10}{30} + \frac{15}{30} - \frac{5}{30} \\
 &= \frac{20}{30} = \frac{2}{3} \qquad \text{Ans.}
 \end{aligned}$$

EXERCISE:

An integer is chosen at random from the first 100 positive integers. What is the probability that the integer chosen is divisible by 6 or by 8?

SOLUTION:

Let A be the event that the integer chosen is divisible by 6, and B be the event that the integer chosen is divisible by 8.

$A \cap B$ is the event that the integer is divisible by both 6 and 8 (i.e. as their L.C.M. is 24)
Now

$$n(A) = \left\lfloor \frac{100}{6} \right\rfloor = 16; \quad n(B) = \left\lfloor \frac{100}{8} \right\rfloor = 12$$

and

$$n(A \cap B) = \left\lfloor \frac{100}{24} \right\rfloor = 4$$

$$\begin{aligned} \text{Hence } P(A \cup B) &= P(A) + P(B) - P(A \cap B) \\ &= \frac{16}{100} + \frac{12}{100} - \frac{4}{100} \\ &= \frac{24}{100} = \frac{6}{25} \quad \text{Ans} \end{aligned}$$

OR

Let A denote the event that the integer chosen is divisible by 6, and B denote the event that the integer chosen is divisible by 8 i.e

$$A = \{6, 12, 18, 24, \dots, 90, 96\} \Rightarrow n(A) = 16 \quad \Rightarrow P(A) = \frac{16}{100}$$

$$B = \{8, 16, 24, 40, \dots, 88, 96\} \Rightarrow n(B) = 12 \quad \Rightarrow P(B) = \frac{12}{100}$$

$$A \cap B = \{24, 48, 72, 96\} \Rightarrow n(A \cap B) = 4 \quad \Rightarrow P(A \cap B) = \frac{4}{100}$$

EXERCISE:

A student attends mathematics class with probability 0.7 skips accounting class with probability 0.4, and attends both with probability 0.5. Find the probability that

- (1) he attends at least one class
- (2) he attends exactly one class

SOLUTION:

(1) Let A be the event that the student attends mathematics class and B be the event that the student attends accounting class.

Then given

$$P(A) = 0.7; \quad P(B) = 1 - 0.4 = 0.6$$

$$\text{And } P(A \cap B) = 0.5, \quad P(A \cup B) = ?$$

By addition law of probability

$$\begin{aligned} P(A \cup B) &= P(A) + P(B) - P(A \cap B) \\ &= 0.7 + 0.6 - 0.5 \\ &= 0.8 \end{aligned}$$

(2) Students can attend exactly one class in two ways

(a) He attends mathematics class but not accounting i.e., event $A \cap B^c$ or

(b) He does not attend mathematics class and attends accounting class i.e., event $A^c \cap B$

Since the two event $A \cap B^c$ and $A^c \cap B$ are disjoint, hence required probability is

$$P(A \cap B^c) + P(A^c \cap B)$$

Now

$$\begin{aligned} P(A \cap B^c) &= P(A \setminus B) \\ &= P(A) - P(A \cap B) \\ &= 0.7 - 0.5 \\ &= 0.2 \end{aligned}$$

and

$$\begin{aligned} P(A^c \cap B) &= P(B \setminus A) \\ &= P(B) - P(A \cap B) \\ &= 0.6 - 0.5 \\ &= 0.1 \end{aligned}$$

Hence required probability is

$$P(A \cap B^c) + P(A^c \cap B) = 0.2 + 0.1 = 0.3$$

PROBABILITY OF SUB EVENT

THEOREM:

If A and B are two events such that $A \subseteq B$, then $P(A) \leq P(B)$

PROOF:

Suppose $A \subseteq B$. The event B may be written as the union of disjoint events $B \cap A$ and $B \cap \bar{A}$

$$\text{i.e., } B = (B \cap A) \cup (B \cap \bar{A})$$

$$\text{But } B \cap A = A \quad (\text{as } A \subseteq B)$$

$$\text{So } B = A \cup (B \cap \bar{A})$$

$$\therefore P(B) = P(A) + P(B \cap \bar{A})$$

$$\text{But } P(B \cap \bar{A}) \geq 0$$

$$\text{Hence } P(B) \geq P(A)$$

$$\text{Or } P(A) \leq P(B)$$

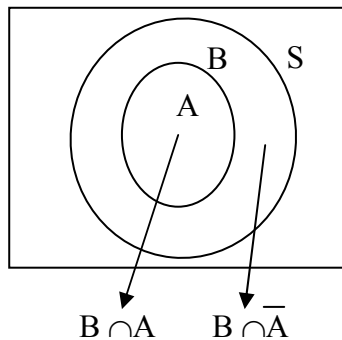
**EXERCISE:**

Let A and B be subsets of a sample space S with $P(A) = 0.7$ and $P(B) = 0.5$. What are the maximum and minimum possible values of $P(A \cup B)$.

SOLUTION:

By addition law of probabilities

$$\begin{aligned} P(A \cup B) &= P(A) + P(B) - P(A \cap B) \\ &= 0.7 + 0.5 - P(A \cap B) \\ &= 1.2 - P(A \cap B) \end{aligned}$$

Since probability of any event is always less than or equal to 1, therefore $\max P(A \cup B) = 1$, for which $P(A \cap B) = 0.2$

Next to find the minimum value, we note

$$\begin{aligned} A \cap B &\subseteq B \\ \Rightarrow P(A \cap B) &\leq P(B) = 0.5 \end{aligned}$$

Thus for $\min P(A \cup B)$ we take maximum possible value of $P(A \cap B)$ which is 0.5. Hence $\min P(A \cup B) = 1.2 - \max P(A \cap B)$
 $= 1.2 - 0.5$
 $= 0.7$ is the required minimum value.

ADDITION LAW OF PROBABILITY FOR THREE EVENTS:

If A, B and C are any three events, then

$$P(A \cup B \cup C) = P(A) + P(B) + P(C) - P(A \cap B) - P(A \cap C) - P(B \cap C) + P(A \cap B \cap C)$$

REMARK:

If A, B, C are mutually disjoint events, then $P(A \cup B \cup C) = P(A) + P(B) + P(C)$

EXERCISE:

Three newspapers A, B, C are published in a city and a survey of readers indicates the following:

20% read A, 16% read B, 14% read C

8% read both A and B, 5% read both A and C

4% read both B and C, 2% read all the three

For a person chosen at random, find the probability that he reads none of the papers.

SOLUTION:

Given

$$P(A) = 20\% = \frac{20}{100} = 0.2; \quad P(B) = 16\% = \frac{16}{100} = 0.16$$

$$P(C) = 14\% = \frac{14}{100} = 0.14; \quad P(A \cap B) = 8\% = \frac{8}{100} = 0.08$$

$$P(A \cap C) = 5\% = \frac{5}{100} = 0.05; \quad P(B \cap C) = 4\% = \frac{4}{100} = 0.04$$

and

$$P(A \cap B \cap C) = 2\% = \frac{2}{100} = 0.02$$

Now the probability that person reads A or B or C = $P(A \cup B \cup C)$

$$= P(A) + P(B) + P(C) - P(A \cap B) - P(A \cap C) - P(B \cap C) + P(A \cap B \cap C)$$

$$= \frac{20}{100} + \frac{16}{100} + \frac{14}{100} - \frac{8}{100} - \frac{5}{100} - \frac{4}{100} + \frac{2}{100}$$

$$= \frac{35}{100}$$

Hence, the probability that he reads none of the papers

$$= P((A \cup B \cup C)^c)$$

$$= 1 - P(A \cup B \cup C)$$

$$= 1 - \frac{35}{100}$$

$$= \frac{65}{100}$$

$$= 65\%$$

EXERCISE:

Let A, B and C be events in a sample space S, with $A \cup B \cup C = S$, $A \cap (B \cup C) = \phi$, $P(A) = 0.2$, $P(B) = 0.5$ and $P(C) = 0.7$. Find $P(A^c)$, $P(B \cup C)$, $P(B \cap C)$.

SOLUTION:

$$P(A^c) = 1 - P(A)$$

$$= 1 - 0.2$$

$$P(A^c) = 0.8$$

Next, given that the events A and $B \cup C$ are disjoint, since $A \cap (B \cup C) = \phi$, therefore

$$P(A \cup (B \cup C)) = P(A) + P(B \cup C)$$

$$\Rightarrow P(S) = 0.2 + P(B \cup C)$$

$$\Rightarrow 1 = 0.2 + P(B \cup C)$$

$$\Rightarrow P(B \cup C) = 1 - 0.2 = 0.8$$

Finally, by addition law of probability

$$P(B \cup C) = P(B) + P(C) - P(B \cap C)$$

$$\Rightarrow 0.8 = 0.5 + 0.7 - P(B \cap C)$$

$\Rightarrow P(B \cap C) = 0.4$ is the required probability

Lecture# 37 Conditional probability

CONDITIONAL PROBABILITY MULTIPLICATION THEOREM INDEPENDENT EVENTS

EXAMPLE:

- What is the probability of getting a 2 when a dice is tossed?
- An even number appears on tossing a die.
 - What is the probability that the number is 2?
 - What is the probability that the number is 3?

SOLUTION:

When a dice is tossed, the sample space is $S = \{1, 2, 3, 4, 5, 6\}$, $n(S) = 6$

- Let "A" denote the event of getting a 2 i.e. $A = \{2\}$, $n(A) = 1$

$$P(2 \text{ appears when the die is tossed}) = \frac{n(A)}{n(S)} = \frac{1}{6}$$

- (i) Let " S_1 " denote the total number of even numbers from a sample space S, when a dice is tossed (i.e. $S_1 \subseteq S$)

$$S_1 = \{2, 4, 6\} \quad n(S_1) = 3$$

Let "B" denote the event of getting a 2 from total number of even number i.e. $B = \{2\}$

$$n(B) = 1$$

$$P(2 \text{ appears; given that the number is even}) = P(B) = \frac{n(B)}{n(S_1)} = \frac{1}{3}$$

- (ii) Let "C" denote the event of getting a 3 in S_1 (among the even numbers) i.e. $C = \{ \}$

$$n(C) = 0$$

$$P(3 \text{ appears; given that the number is even}) = P(C) = \frac{n(C)}{n(S_1)} = \frac{0}{3} = 0$$

EXAMPLE:

Suppose that an urn contains 3 red balls, 2 blue balls, and 4 white balls, and that a ball is selected at random.

Let E be the event that the ball selected is red.

Then $P(E) = 3/9$ (as there are 3 red balls out of total 9 balls)

Let F be the event that the ball selected is not white.

Then the probability of E if it is already known that the selected ball is not white would be

$P(\text{red ball selected; given that the selected ball is not white}) = 3/5$ (as we count no white ball so there are total 9 balls (i.e. 2 blue and 3 red balls))

This is called the conditional probability of E given F and is denoted by $P(E|F)$.

DEFINITION:

Let E and F be two events in the sample space of an experiment with $P(F) \neq 0$. The **conditional probability** of E given F, denoted by $P(E|F)$, is defined as

$$P(E|F) = \frac{P(E \cap F)}{P(F)}$$

EXAMPLE:

Let A and B be events of an experiment such that $P(B) = 1/4$ and $P(A \cap B) = 1/6$.

What is the conditional probability $P(A|B)$?

SOLUTION:

$$P(A|B) = \frac{P(A \cap B)}{P(B)} = \frac{1/6}{1/4} = \frac{4}{6} = \frac{2}{3}$$

EXERCISE:

Let A and B be events with $P(A) = \frac{1}{2}$, $P(B) = \frac{1}{3}$ and $P(A \cap B) = \frac{1}{4}$

Find

- (i) $P(A|B)$ (ii) $P(B|A)$
 (iii) $P(A \cup B)$ (iv) $P(A^c | B^c)$

SOLUTION:

Using the formula of the conditional Probability we can write

$$\begin{aligned} \text{(i)} \quad P(A|B) &= \frac{P(A \cap B)}{P(B)} \\ &= \frac{1/4}{1/3} = \frac{3}{4} \end{aligned}$$

$$\begin{aligned} \text{(ii)} \quad P(B|A) &= \frac{P(B \cap A)}{P(A)} \\ &= \frac{1/4}{1/2} = \frac{2}{4} = \frac{1}{2} \quad (\text{As } P(B \cap A) = P(A \cap B) = 1/4) \end{aligned}$$

$$\begin{aligned} \text{(iii)} \quad P(A \cup B) &= P(A) + P(B) - P(A \cap B) \\ &= \frac{1}{2} + \frac{1}{3} - \frac{1}{4} \\ &= \frac{7}{12} \end{aligned}$$

$$\begin{aligned}
 \text{(iv)} \quad P(A^c | B^c) &= \frac{P(A^c \cap B^c)}{P(B^c)} \\
 &= \frac{P((A \cup B)^c)}{P(B^c)} \quad (\text{By using DeMorgan's Law}) \\
 &= \frac{1 - P(A \cup B)}{1 - P(B)} \quad [P(E^c) = 1 - P(E)] \\
 &= \frac{1 - 7/12}{1 - 1/3} = \frac{5/12}{2/3} = \frac{5}{12} \times \frac{3}{2} = \frac{5}{8}
 \end{aligned}$$

EXERCISE:Find $P(B|A)$ if

- (i) A is a subset of B
(ii) A and B are mutually exclusive

SOLUTION:

- (i) When $A \subseteq B$, then $B \cap A = A$ (As $A \cap A \subseteq B \cap A$ $\square \square \subseteq B \cap A$ (i)
also we know that $B \cap A \subseteq A$ (ii), From (i) and (ii) clearly $B \cap A = A$)

$$\begin{aligned}
 \therefore P(B | A) &= \frac{P(B \cap A)}{P(A)} \quad (\text{as } B \cap A = A \Rightarrow P(B \cap A) = P(A)) \\
 &= \frac{P(A)}{P(A)} = 1
 \end{aligned}$$

- (ii) When A and B are mutually exclusive, then $B \cap A = \emptyset$

$$\begin{aligned}
 \therefore P(B | A) &= \frac{P(B \cap A)}{P(A)} \\
 &= \frac{P(\emptyset)}{P(A)} \quad (\text{Since } B \cap A = \emptyset \Rightarrow P(B \cap A) = 0) \\
 &= \frac{0}{P(A)} = 0 \quad (\text{as } P(\emptyset) = 0)
 \end{aligned}$$

EXAMPLE:

Suppose that an urn contains **three** red balls marked 1, 2, 3, one blue ball marked 4, and **four** white balls marked 5, 6, 7, 8.

A ball is selected at random and its color and number noted.

- (i) What is the probability that it is red?
(ii) What is the probability that it has an even number marked on it?
(iii) What is the probability that it is red, if it is known that the ball selected has an even number marked on it?
(iv) What is the probability that it has an even number marked on it, if it is known that the ball selected is red?

SOLUTION:

Let E be the event that the ball selected is red .

(i) $P(E) = 3/8$

let F be the event that the ball selected has an even number marked on it.

(ii) $P(F) = 4/8$ (as there are four even numbers 2,4,6 & 8 out of total eight numbers).

(iii) $E \cap F$ is the event that the ball selected is red and has an even number marked on it.

Clearly $P(E \cap F) = 1/8$ (as there is only one ball which is red and marked an even number "2" out of total eight balls).

Hence,

$P(\text{Selected ball is red, given that the ball selected has an even number marked on it.}) = P(E|F)$

$$= \frac{P(E \cap F)}{P(F)} = \frac{1/8}{4/8} = 1/4$$

(iv) $P(\text{Selected ball has an even number marked on it, given that the ball selected is red}) = P(F|E)$

$$= \frac{P(E \cap F)}{P(E)} = \frac{1/8}{3/8} = \frac{1}{3}$$

EXAMPLE:

Let a pair of dice be tossed. If the sum is 7, find the probability that one of the dice is 2.

SOLUTION:

Let E be the event that a 2 appears on at least one of the two dice, and F be the event that the sum is 7.

Then

$$E = \{(1, 2), (2, 1), (2, 2), (2, 3), (2, 4), (2, 5), (2, 6), (3, 2), (4, 2), (5, 2), (6, 2)\}$$

$$F = \{(1, 6), (2, 5), (3, 4), (4, 3), (5, 2), (6, 1)\}$$

$$E \cap F = \{(2, 5), (5, 2)\}$$

$$P(F) = 6/36 \quad \text{and} \quad P(E \cap F) = 2/36.$$

Hence,

$P(\text{Probability that one of the dice is 2, given that the sum is 7}) = P(E|F)$

$$= \frac{P(E \cap F)}{P(F)} = \frac{2/36}{6/36} = \frac{1}{3}$$

EXAMPLE:

A man visits a family who has two children. One of the children, a boy, comes into the room.

Find the probability that the other child is also a boy if

(i) The other child is known to be elder,

(ii) Nothing is known about the other child.

SOLUTION:

The sample space of the experiment is $S = \{bb, bg, gb, gg\}$

(The outcome bg specifies that younger is a boy and elder is a girl, etc.)

Let A be the event that both the children are boys.

Then, $A = \{bb\}$.

(i) Let B be the event that the younger is a boy. Then, $B = \{bb, bg\}$, and $A \cap B = \{bb\}$.

Hence, the required probability is

$P(\text{Probability that the other child is also a boy, given that the other child is elder}) =$

$$P(A|B) = \frac{P(A \cap B)}{P(B)} = \frac{1/4}{2/4} = \frac{1}{2}$$

(ii) Let C be the event that one of the children is a boy.

Then $C = \{bb, bg, gb\}$, and $A \cap C = \{bb\}$.

Hence, the required probability is

$P(\text{Probability that both the children are boys, given that one of the children is a boy}) =$

$$= P(A|C)$$

$$= \frac{P(A \cap C)}{P(C)} = \frac{1/4}{3/4} = \frac{1}{3}$$

MULTIPLICATION THEOREM

Let E and F be two events in the sample space of an experiment, then

$$P(E \cap F) = P(F)P(E | F)$$

$$\text{Or } P(E \cap F) = P(E)P(F | E)$$

Let E_1, E_2, \dots, E_n be events in the sample space of an experiment, then

$$P(E_1 \cap E_2 \cap \dots \cap E_n) = P(E_1)P(E_2 | E_1)P(E_3 | E_1 \cap E_2) \dots P(E_n | E_1 \cap E_2 \cap \dots \cap E_{n-1})$$

EXAMPLE:

A lot contains 12 items of which 4 are defective. Three items are drawn at random from the lot one after the other. What is the probability that all three are non-defective?

SOLUTION:

Let A_1 be the event that the first item is not defective.

Let A_2 be the event that the second item is not defective.

Let A_3 be the event that the third item is not defective.

Then $P(A_1) = 8/12$, $P(A_2|A_1) = 7/11$, and $P(A_3|A_1 \cap A_2) = 6/10$

Hence, by multiplication theorem, the probability that all three are non-defective is

$$P(A_1 \cap A_2 \cap A_3) = P(A_1) P(A_2|A_1) P(A_3|A_1 \cap A_2)$$

$$= \frac{8}{12} \cdot \frac{7}{11} \cdot \frac{6}{10} = \frac{14}{55}$$

INDEPENDENCE:

An event A is said to be independent of an event B if the probability that A occurs is not influenced by whether B has or has not occurred. That is, $P(A|B) = P(A)$.

It follows then from the Multiplication Theorem that,

$$P(A \cap B) = P(B)P(A|B) = P(B)P(A)$$

We also know that,

$$\begin{aligned} P(B|A) &= \frac{P(A \cap B)}{P(A)} \\ &= \frac{P(A)P(B)}{P(A)} && \text{Because } P(A \cap B) = P(A)P(B) \text{ ,due to independence} \\ &= P(B) \end{aligned}$$

EXAMPLE:

Let A be the event that a randomly generated bit string of length four begins with a 1 and let B be the event that a randomly generated bit string of length four contains an even number of 0s.

Are A and B independent events?

SOLUTION:

$$A = \{1000, 1001, 1010, 1011, 1100, 1101, 1110, 1111\}$$

$$B = \{0000, 0011, 0101, 0110, 1001, 1010, 1100, 1111\}$$

Since there are 16 bit strings of length four, we have

$$P(A) = 8/16 = 1/2, \quad P(B) = 8/16 = 1/2$$

Also,

$$A \cap B = \{1001, 1010, 1100, 1111\} \text{ so that } P(A \cap B) = 4/16 = 1/4$$

We note that,

$$P(A \cap B) = \frac{1}{4} = \frac{1}{2} \cdot \frac{1}{2} = P(A)P(B)$$

Hence A and B are independent events.

EXAMPLE:

Let a fair coin be tossed three times. Let A be the event that first toss is heads, B be the event that the second toss is a heads, and C be the event that exactly two heads are tossed in a row. Examine pair wise independence of the three events.

SOLUTION:

The sample space of the experiment is

$$S = \{HHH, HHT, HTH, HTT, THH, THT, TTH, TTT\} \text{ and the events are}$$

$$A = \{HHH, HHT, HTH, HTT\}$$

$$B = \{HHH, HHT, THH, THT\}$$

$$C = \{HHT, THH\}$$

$$A \cap B = \{HHH, HHT\}, A \cap C = \{HHT\}, B \cap C = \{HHT, THH\}$$

It follows that

$$P(A) = 4/8 = 1/2$$

$$P(B) = 4/8 = 1/2$$

$$P(C) = 2/8 = 1/4$$

and

$$P(A \cap B) = 2/8 = 1/4$$

$$P(A \cap C) = 1/8$$

$$P(B \cap C) = 2/8 = 1/4$$

Note that,

$$P(A)P(B) = \frac{1}{2} \cdot \frac{1}{2} = \frac{1}{4} = P(A \cap B), \text{ so that A and B are independent.}$$

$$P(A)P(C) = \frac{1}{2} \cdot \frac{1}{4} = \frac{1}{8} = P(A \cap C), \text{ so that A and C are independent.}$$

$$P(B)P(C) = \frac{1}{2} \cdot \frac{1}{4} = \frac{1}{8} \neq P(B \cap C), \text{ so that B and C are dependent.}$$

EXAMPLE:

The probability that A hits a target is $1/3$ and the probability that B hits the target is $2/5$. What is the probability that target will be hit if A and B each shoot at the target?

SOLUTION:

It is clear from the nature of the experiment that the two events are independent.

Hence,

$$P(A \cap B) = P(A)P(B)$$

It follows that,

$$\begin{aligned} P(A \cup B) &= P(A) + P(B) - P(A \cap B) \\ &= P(A) + P(B) - P(A)P(B) \quad (\text{due to independence}) \\ &= \frac{1}{3} + \frac{2}{5} - \frac{1}{3} \cdot \frac{2}{5} \\ &= \frac{3}{5} \end{aligned}$$

Lecture# 38 Random variable

RANDOM VARIABLE PROBABILITY DISTRIBUTION EXPECTATION AND VARIANCE

INTRODUCTION:

Suppose S is the sample space of some experiment. The outcomes of the experiment, or the points in S , need not be numbers. For example in tossing a coin, the outcomes are H (heads) or T (tails), and in tossing a pair of dice the outcomes are pairs of integers. However, we frequently wish to assign a specific number to each outcome of the experiment. For example, in coin tossing, it may be convenient to assign 1 to H and 0 to T; or in the tossing of a pair of dice, we may want to assign the sum of the two integers to the outcome. Such an assignment of numerical values is called a random variable.

RANDOM VARIABLE:

A random variable X is a rule that assigns a numerical value to each outcome in a sample Space S .

OR

It is a function which maps each outcome of the sample space into the set of real numbers.

We shall let $X(S)$ denote the set of numbers assigned by a random variable X , and refer to $X(S)$ as the range space.

In formal terminology, X is a function from S (sample space) to the set of real numbers R , and $X(S)$ is the range of X .

REMARK:

1. A random variable is also called a chance variable, or a stochastic variable (not called simply a variable, because it is a function).
2. Random variables are usually denoted by capital letters such as X, Y, Z ; and the values taken by them are represented by the corresponding small letters.

EXAMPLE:

A pair of fair dice is tossed. The sample space S consists of the 36 ordered pairs i.e

$$S = \{(1,1), (1,2), (1,3), \dots, (6,6)\}$$

Let X assign to each point in S the sum of the numbers; then X is a random variable with range space i.e

$$X(S) = \{2,3,4,5,6,7,8,9,10,11,12\}$$

Let Y assign to each point in S the maximum of the two numbers in the outcomes; then Y is a random variable with range space.

$$Y(S) = \{1,2,3,4,5,6\}$$

PROBABILITY DISTRIBUTION OF A RANDOM VARIABLE:

Let $X(S) = \{x_1, x_2, \dots, x_n\}$ be the range space of a random variable X defined on a finite sample space S .

Define a function f on $X(S)$ as follows:

$$f(x_i) = P(X = x_i)$$

= sum of probabilities of points in S whose image is x_i .

This function f is called the probability distribution or the probability function of X .
The probability distribution f of X is usually given in the form of a table.

x_1	x_2	...	x_n
$f(x_1)$	$f(x_2)$...	$f(x_n)$

The distribution f satisfies the conditions.

$$(i) \quad f(x_i) \geq 0 \quad \text{and} \quad (ii) \quad \sum_{i=1}^n f(x_i) = 1$$

EXAMPLE:

A pair of fair dice is tossed. Let X assign to each point (a, b) in $S = \{(1,1), (1,2), \dots, (6,6)\}$, the sum of its number, i.e., $X(a,b) = a+b$. Compute the distribution f of X .

SOLUTION:

X is clearly a random variable with range space $X(S) = \{2,3,4,5,6,7,8,9,10, 11, 12\}$
(because $X(a,b) = a+b \Rightarrow X(1,1) = 1+1=2, X(1,2) = 1+2=3, X(1,3) = 1+3=4$ etc).

The distribution f of X may be computed as:

$$f(2) = P(X=2) = P(\{(1,1)\}) = \frac{1}{36}$$

$$f(3) = P(X=3) = P(\{(1,2), (2,1)\}) = \frac{2}{36}$$

$$f(4) = P(X=4) = P(\{(1,3), (2,2), (3,1)\}) = \frac{3}{36}$$

$$f(5) = P(X=5) = P(\{(1,4), (2,3), (3,2), (4,1)\}) = \frac{4}{36}$$

$$f(6) = P(X = 6) = P(\{(1,5), (2,4), (3,3), (4,2), (5,1)\}) = \frac{5}{36}$$

$$f(7) = P(X = 7) = P(\{(1,6), (2,5), (3,4), (4,3), (5,2), (6,2)\}) = \frac{6}{36}$$

$$f(8) = P(X = 8) = P(\{(2,6), (3,5), (4,4), (5,3), (6,2)\}) = \frac{5}{36}$$

$$f(9) = P(X = 9) = P(\{(3,6), (4,5), (5,4), (6,3)\}) = \frac{4}{36}$$

$$f(10) = P(X = 10) = P(\{(4,6), (5,5), (6,4)\}) = \frac{3}{36}$$

$$f(11) = P(X = 11) = P(\{(5, 6), (6, 5)\}) = \frac{2}{36}$$

$$f(12) = P(X = 12) = P(\{(6, 6)\}) = \frac{1}{36}$$

The distribution of X consists of the points in $X(S)$ with their respective probabilities.

x_i	2	3	4	5	6	7	8	9	10	11	12
$f(x_i)$	1/36	2/36	3/36	4/36	5/36	6/36	5/36	4/36	3/36	2/36	1/36

EXAMPLE:

A box contains 12 items of which three are defective. A sample of three items is selected from the box.

If X denotes the number of defective items in the sample; find the distribution of X .

SOLUTION:

The sample space S consists of $\binom{12}{3} = 220$ that is 220 different samples of size 3.

The random variable X , denoting the number of defective items has the range space $X(S) = \{0, 1, 2, 3\}$

There are $\binom{3}{0} \binom{9}{3} = 84$ samples of size 3 with no defective items;

hence

$$p_0 = P(X = 0) = \frac{84}{220}$$

There are $\binom{3}{1} \binom{9}{2} = 108$ samples of size 3 containing one defective item;

hence

$$p_1 = P(X = 1) = \frac{108}{220}$$

There are $\binom{3}{2} \binom{9}{1} = 27$ samples of size 3 containing two defective items;

hence

$$p_2 = P(X = 2) = \frac{27}{220}$$

Finally, there is $\binom{3}{3} \binom{9}{0} = 1$, only one sample of size 3 containing three

defective items;

hence

$$p_3 = P(X = 3) = \frac{1}{220}$$

The distribution of X follows:

x_i	0	1	2	3
p_i	84/220	108/220	27/220	1/220

EXPECTATION OF A RANDOM VARIABLE

Let X be a random variable with probability distribution

x_i	x_1	x_2	x_3	...	x_n
$f(x_i)$	$f(x_1)$	$f(x_2)$	$f(x_3)$...	$f(x_n)$

The mean (denoted μ) or the expectation of X (written $E(X)$) is defined by

$$\mu = E(X) = x_1 f(x_1) + x_2 f(x_2) + \dots + x_n f(x_n)$$

$$= \sum_{i=1}^n x_i f(x_i)$$

EXAMPLE:

What is the expectation of the number of heads when three fair coins are tossed?

SOLUTION:

The sample space of the experiment is:

$$S = \{TTT, TTH, THT, HTT, THH, HTH, HHT, HHH\}$$

Let the random variable X represents the number of heads (i.e 0,1,2,3) when three fair coins are tossed. Then X has the probability distribution.

x_i	$x_0=0$	$x_1=1$	$x_2=2$	$x_3=3$
$f(x_i)$	1/8	3/8	3/8	1/8

Hence, expectation of X is

$$\begin{aligned} E(X) &= x_0 f(x_0) + x_1 f(x_1) + x_2 f(x_2) + x_3 f(x_3) \\ &= 0 \cdot \frac{1}{8} + 1 \cdot \frac{3}{8} + 2 \cdot \frac{3}{8} + 3 \cdot \frac{1}{8} = \frac{12}{8} = 1.5 \end{aligned}$$

EXERCISE:

A player tosses two fair coins. He wins Rs. 1 if one head appears, Rs.2 if two heads appear. On the other hand, he loses Rs.5 if no heads appear. Determine the expected value E of the game and if it is favourable to be player.

SOLUTION:

The sample space of the experiment is $S = \{HH, HT, TH, TT\}$

Now

$$P(\text{Two heads}) = P(HH) = \frac{1}{2} \cdot \frac{1}{2} = \frac{1}{4}$$

$$P(\text{One head}) = P(HT, TH) = \frac{1}{2} \cdot \frac{1}{2} + \frac{1}{2} \cdot \frac{1}{2} = \frac{1}{2}$$

$$P(\text{No heads}) = P(TT) = \frac{1}{2} \cdot \frac{1}{2} = \frac{1}{4}$$

Thus, the probability of winning Rs.2 is $\frac{1}{4}$, of winning Rs 1 is $\frac{1}{2}$ and of losing Rs 5 is $\frac{1}{4}$

Hence,

$$\begin{aligned} E &= 2\left(\frac{1}{4}\right) + 1\left(\frac{1}{2}\right) - 5\left(\frac{1}{4}\right) \\ &= -\frac{1}{4} = -0.25 \end{aligned}$$

Since, the expected value of the game is negative, so it is unfavorable to the player.

EXAMPLE:

A coin is weighted so that and $P(H) = \frac{3}{4}$ and $P(T) = \frac{1}{4}$

The coin is tossed three times.

Let X denotes the number of heads that appear.

- (a) Find the distribution of X
 (b) Find the expectation of E(X)

SOLUTION:

(a) The sample space is $S = \{HHH, HHT, HTH, THH, HTT, THT, TTH, TTT\}$

The probabilities of the points in sample space are

$$p(HHH) = \frac{3}{4} \cdot \frac{3}{4} \cdot \frac{3}{4} = \frac{27}{64}$$

$$p(HHT) = \frac{3}{4} \cdot \frac{3}{4} \cdot \frac{1}{4} = \frac{9}{64}$$

$$p(HTH) = \frac{3}{4} \cdot \frac{1}{4} \cdot \frac{3}{4} = \frac{9}{64}$$

$$p(THH) = \frac{1}{4} \cdot \frac{3}{4} \cdot \frac{3}{4} = \frac{9}{64}$$

$$p(HTT) = \frac{3}{4} \cdot \frac{1}{4} \cdot \frac{1}{4} = \frac{3}{64}$$

$$p(THT) = \frac{1}{4} \cdot \frac{3}{4} \cdot \frac{1}{4} = \frac{3}{64}$$

$$p(TTH) = \frac{1}{4} \cdot \frac{1}{4} \cdot \frac{3}{4} = \frac{3}{64}$$

$$p(TTT) = \frac{1}{4} \cdot \frac{1}{4} \cdot \frac{1}{4} = \frac{1}{64}$$

The random variable X denoting the number of heads assumes the values 0,1,2,3 with the probabilities:

$$P(0) = P(TTT) = \frac{1}{64}$$

$$P(1) = P(HTT, THT, TTH) = \frac{3}{64} + \frac{3}{64} + \frac{3}{64} = \frac{9}{64}$$

$$P(2) = P(HHT, HTH, THH) = \frac{9}{64} + \frac{9}{64} + \frac{9}{64} = \frac{27}{64}$$

$$P(3) = P(HHH) = \frac{27}{64}$$

Hence, the distribution of X is

x_i	0	1	2	3
$P(x_i)$	1/64	9/64	27/64	27/64

(b) The expected value $E(X)$ is obtained by multiplying each value of X by its probability and taking the sum.

The distribution of X is

x_i	0	1	2	3
$P(x_i)$	1/64	9/64	27/64	27/64

Hence

$$\begin{aligned} E(X) &= 0\left(\frac{1}{64}\right) + 1\left(\frac{9}{64}\right) + 2\left(\frac{27}{64}\right) + 3\left(\frac{27}{64}\right) \\ &= \frac{144}{64} \\ &= 2.25 \end{aligned}$$

VARIANCE AND STANDARD DEVIATION OF A RANDOM VARIABLE:

Let X be a random variable with mean μ and the probability distribution

x_1	x_2	x_3	...	x_n
$f(x_1)$	$f(x_2)$	$f(x_3)$...	$f(x_n)$

The variance of X, measures the “spread” or “dispersion” of X from the mean μ and is denoted and defined as

$$\begin{aligned}
 \sigma_x^2 = \text{Var}(X) &= \sum_{i=1}^n (x_i - \mu)^2 f(x_i) \\
 &= E((X - \mu)^2) \\
 &= E(X^2) - \mu^2 \\
 &= \sum x_i^2 f(x_i) - \mu^2
 \end{aligned}$$

The last expression is a more convenient form for computing $\text{Var}(X)$.

The standard deviation of X , denoted by σ_x , is the non-negative square root of $\text{Var}(X)$:

Where $\sigma_x = \sqrt{\text{Var}(X)}$

EXERCISE:

Find the expectation μ , variance σ^2 and standard deviation σ of the distribution given in the following table.

x_i	1	3	4	5
$f(x_i)$	0.4	0.1	0.2	0.3

SOLUTION:

$$\begin{aligned}
 \mu = E(X) &= \sum x_i f(x_i) \\
 &= 1(0.4) + 3(0.1) + 4(0.2) + 5(0.3) \\
 &= 0.4 + 0.3 + 0.8 + 1.5 \\
 &= 3.0
 \end{aligned}$$

Next

$$\begin{aligned}
 E(X^2) &= \sum x_i^2 f(x_i) \\
 &= 1^2 (0.4) + 3^2 (0.1) + 4^2 (0.2) + 5^2 (0.3) \\
 &= 0.4 + 0.9 + 3.2 + 7.5 \\
 &= 12.0
 \end{aligned}$$

Hence

$$\begin{aligned}
 \sigma^2 = \text{Var}(X) &= E(X^2) - \mu^2 \\
 &= 12.0 - (3.0)^2 = 3.0
 \end{aligned}$$

and $\sigma = \sqrt{\text{Var}(X)} = \sqrt{3.0} \approx 1.7$

EXERCISE:

A pair of fair dice is thrown. Let X denote the maximum of the two numbers which appears.

(a) Find the distribution of X

(b) Find the μ , variance $\sigma_x^2 = \text{Var}(X)$, and standard deviation σ_x of X

SOLUTION:

(a) The sample space S consist of the 36 pairs of integers (a,b) where a and b range from 1 to 6;

that is $S = \{(1,1), (1,2), \dots, (6,6)\}$

Since X assigns to each pair in S the larger of the two integers, the value of X are the integers from 1 to 6.

Note that:

$$f(1) = P(X = 1) = P(\{(1,1)\}) = \frac{1}{36}$$

$$f(2) = P(X = 2) = P(\{(2,1), (2,2), (1,2)\}) = \frac{3}{36}$$

$$f(3) = P(X = 3) = P(\{(3,1), (3,2), (3,3), (2,3), (1,3)\}) = \frac{5}{36}$$

$$f(4) = P(X = 4) = P(\{(4,1), (4,2), (4,3), (4,4), (3,4), (2,4), (1,4)\}) = \frac{7}{36}$$

Similarly

$$\begin{aligned} f(5) &= P(X = 5) = \{(1,5), (2,5), (3,5), (4,5), (5,1), (5,2), (5,3), (5,4), (5,5)\} \\ &= \frac{9}{36} \end{aligned}$$

and

$$\begin{aligned} f(6) &= P(X = 6) = \{(1,6), (2,6), (3,6), (4,6), (5,6), (6,1), (6,2), (6,3), (6,4), (6,5), (6,6)\} \\ &= \frac{11}{36} \end{aligned}$$

Hence, the probability distribution of x is:

x_i	1	2	3	4	5	6
$f(x_i)$	1/36	3/36	5/36	7/36	9/36	11/36

(b) We find the expectation (mean) of X as

$$\begin{aligned} \mu = E(X) &= \sum x_i f(x_i) \\ &= 1 \cdot \frac{1}{36} + 2 \cdot \frac{3}{36} + 3 \cdot \frac{5}{36} + 4 \cdot \frac{7}{36} + 5 \cdot \frac{9}{36} + 6 \cdot \frac{11}{36} \\ &= \frac{161}{36} \approx 4.5 \end{aligned}$$

Next

$$\begin{aligned} E(X^2) &= \sum x_i^2 f(x_i) \\ &= 1^2 \cdot \frac{1}{36} + 2^2 \cdot \frac{3}{36} + 3^2 \cdot \frac{5}{36} + 4^2 \cdot \frac{7}{36} + 5^2 \cdot \frac{9}{36} + 6^2 \cdot \frac{11}{36} \\ &= \frac{791}{36} \approx 22.0 \end{aligned}$$

Then

$$\begin{aligned}\sigma_x^2 = \text{Var}(X) &= E(X^2) - \mu^2 \\ &= 22.0 - (4.5)^2 \\ &= 17.5\end{aligned}$$

and

$$\sigma_x = \sqrt{17.5} \approx 1.3$$

Lecture# 39 Introduction to graphs

INTRODUCTION TO GRAPHS

INTRODUCTION:

Graph theory plays an important role in several areas of computer science such as:

- switching theory and logical design
- artificial intelligence
- formal languages
- computer graphics
- operating systems
- compiler writing
- information organization and retrieval.

GRAPH:

A graph is a non-empty set of points called vertices and a set of line segments joining pairs of vertices called edges.

Formally, a graph G consists of two finite sets:

- (i) A set $V=V(G)$ of vertices (or points or nodes)
- (ii) A set $E=E(G)$ of edges; where each edge corresponds to a pair of vertices.

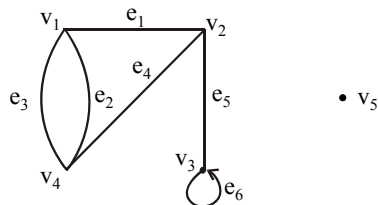

The graph G with

$V(G) = \{v_1, v_2, v_3, v_4, v_5\}$ and

$E(G) = \{e_1, e_2, e_3, e_4, e_5, e_6\}$

SOME TERMINOLOGY:

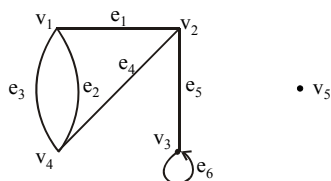

1. An edge connects either one or two vertices called its **endpoints** (edge e_1 connects vertices v_1 and v_2 described as $\{v_1, v_2\}$ i.e. v_1 and v_2 are the endpoints of an edge e_1).
2. An edge with just one endpoint is called a **loop**. Thus a loop is an edge that connects a vertex to itself (e.g., edge e_6 makes a loop as it has only one endpoint v_3).
3. Two vertices that are connected by an edge are called **adjacent**; and a vertex that is an endpoint of a loop is said to be adjacent to itself.
4. An edge is said to be **incident** on each of its endpoints(i.e. e_1 is incident on v_1 and v_2).

5. A vertex on which no edges are incident is called **isolated** (e.g., v_5)
 6. Two distinct edges with the same set of end points are said to be **parallel** (i.e. e_2 & e_3).

EXAMPLE:

Define the following graph formally by specifying its vertex set, its edge set, and a table giving the edge endpoint function.

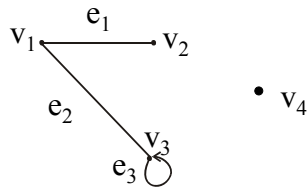
**SOLUTION:**

Vertex Set = $\{v_1, v_2, v_3, v_4\}$

Edge Set = $\{e_1, e_2, e_3\}$

Edge - endpoint function is:

Edge	Endpoint
e_1	$\{v_1, v_2\}$
e_2	$\{v_1, v_3\}$
e_3	$\{v_3\}$

EXAMPLE:

For the graph shown below

- (i) find all edges that are incident on v_1 ;
 (ii) find all vertices that are adjacent to v_3 ;
 (iii) find all loops;
 (iv) find all parallel edges;
 (v) find all isolated vertices;

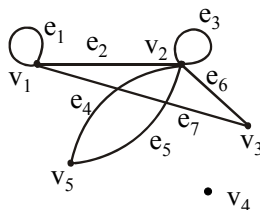
**SOLUTION:**

- (i) v_1 is incident with edges e_1, e_2 and e_7
 (ii) vertices adjacent to v_3 are v_1 and v_2
 (iii) loops are e_1 and e_3
 (iv) only edges e_4 and e_5 are parallel
 (v) The only isolated vertex is v_4 in this Graph.

DRAWING PICTURE FOR A GRAPH:

Draw picture of Graph H having vertex set $\{v_1, v_2, v_3, v_4, v_5\}$ and edge set $\{e_1, e_2, e_3, e_4\}$ with edge endpoint function

Edge	Endpoint
e_1	$\{v_1\}$
e_2	$\{v_2, v_3\}$
e_3	$\{v_2, v_3\}$
e_4	$\{v_1, v_5\}$

SOLUTION:

Given $V(H) = \{v_1, v_2, v_3, v_4, v_5\}$
and $E(H) = \{e_1, e_2, e_3, e_4\}$
with edge endpoint function

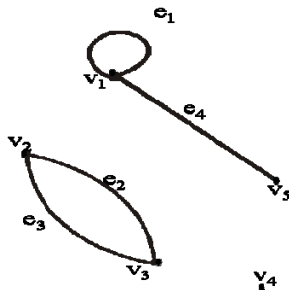
**SIMPLE GRAPH**

A simple graph is a graph that does not have any loop or parallel edges.

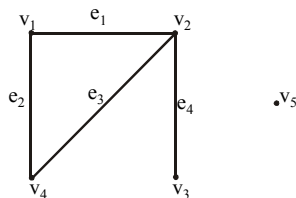
EXAMPLE:

It is a simple graph H

$V(H) = \{v_1, v_2, v_3, v_4, v_5\}$ & $E(H) = \{e_1, e_2, e_3, e_4\}$

EXERCISE:

Draw all simple graphs with the four vertices $\{u, v, w, x\}$ and two edges, one of which is $\{u, v\}$.

SOLUTION:

There are $C(4,2) = 6$ ways of choosing two vertices from 4 vertices. These edges may be listed as:

$$\{u,v\}, \{u,w\}, \{u,x\}, \{v,w\}, \{v,x\}, \{w,x\}$$

One edge of the graph is specified to be $\{u,v\}$, so any of the remaining five from this list may be chosen to be the second edge. This required graphs are:

1.

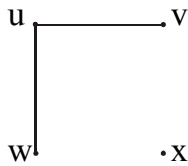

2.

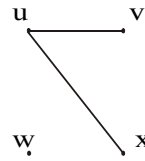

4.

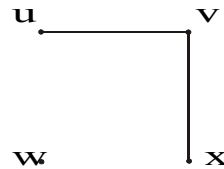

3.

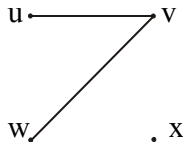

5.

**DEGREE OF A VERTEX:**

Let G be a graph and v a vertex of G . The degree of v , denoted $\deg(v)$, equals the number of edges that are incident on v , with an edge that is a loop counted twice.

Note:(i) The **total degree** of G is the sum of the degrees of all the vertices of G .

(ii) The **degree** of a loop is counted twice.

EXAMPLE:

For the graph shown

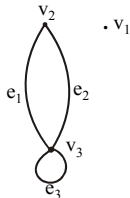

$\deg(v_1) = 0$, since v_1 is isolated vertex.

$\deg(v_2) = 2$, since v_2 is incident on e_1 and e_2 .

$\deg(v_3) = 4$, since v_3 is incident on e_1, e_2 and the loop e_3 .

$$\begin{aligned} \text{Total degree of } G &= \deg(v_1) + \deg(v_2) + \deg(v_3) \\ &= 0 + 2 + 4 \\ &= 6 \end{aligned}$$

REMARK:

The total degree of G , which is 6, equals twice the number of edges of G , which is 3.

THE HANDSHAKING THEOREM:

If G is any graph, then the sum of the degrees of all the vertices of G equals twice the number of edges of G .

Specifically, if the vertices of G are v_1, v_2, \dots, v_n , where n is a positive integer, then the total degree of $G = \deg(v_1) + \deg(v_2) + \dots + \deg(v_n)$

$$= 2 \cdot (\text{the number of edges of } G)$$

PROOF:

Each edge “e” of G connects its end points v_i and v_j . This edge, therefore contributes 1 to the degree of v_i and 1 to the degree of v_j .

If “e” is a loop, then it is counted twice in computing the degree of the vertex on which it is incident.

Accordingly, each edge of G contributes 2 to the total degree of G.

Thus,

$$\text{the total degree of } G = 2 \cdot (\text{the number of edges of } G)$$

COROLLARY:

The total degree of G is an even number

EXERCISE:

Draw a graph with the specified properties or explain why no such graph exists.

- (i) Graph with four vertices of degrees 1, 2, 3 and 3
- (ii) Graph with four vertices of degrees 1, 2, 3 and 4
- (iii) Simple graph with four vertices of degrees 1, 2, 3 and 4

SOLUTION:

- (i) Total degree of graph $= 1 + 2 + 3 + 3$
 $= 9$ an odd integer

Since, the total degree of a graph is always even, hence no such graph is possible.

Note: As we know that “for any graph, the sum of the degrees of all the vertices of G equals twice the number of edges of G or the total degree of G is an even number”.

- (ii) Two graphs with four vertices of degrees 1, 2, 3 & 4 are

1.

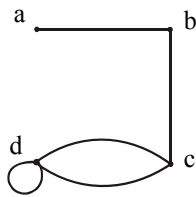

or

2.

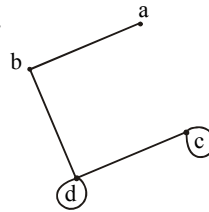

The vertices a, b, c, d have degrees 1, 2, 3, and 4 respectively (i.e. graph exists).

- (iii) Suppose there was a simple graph with four vertices of degrees 1, 2, 3, and 4. Then the vertex of degree 4 would have to be connected by edges to four distinct vertices other than itself because of the assumption that the graph is simple (and hence has no loop or parallel edges.) This contradicts the assumption that the graph has four vertices in total. Hence there is no simple graph with four vertices of degrees 1, 2, 3, and 4, so simple graph is not possible in this case.

EXERCISE:

Suppose a graph has vertices of degrees 1, 1, 4, 4 and 6. How many edges does the graph have?

SOLUTION:

$$\begin{aligned} \text{The total degree of graph} &= 1 + 1 + 4 + 4 + 6 \\ &= 16 \end{aligned}$$

Since, the total degree of graph = 2.(number of edges of graph) [by using Handshaking theorem]

$$\Rightarrow 16 = 2.(\text{number of edges of graph})$$

$$\Rightarrow \text{Number of edges of graph} = \frac{16}{2} = 8$$

EXERCISE:

In a group of 15 people, is it possible for each person to have exactly 3 friends?

SOLUTION:

Suppose that in a group of 15 people, each person had exactly 3 friends. Then we could draw a graph representing each person by a vertex and connecting two vertices by an edge if the corresponding people were friends. But such a graph would have 15 vertices each of degree 3, for a total degree of 45 (not even) which is not possible.

Hence, in a group of 15 people it is not possible for each to have exactly three friends.

COMPLETE GRAPH:

A complete graph on n vertices is a simple graph in which each vertex is connected to every other vertex and is denoted by K_n (K_n means that there are n vertices).

The following are complete graphs K_1, K_2, K_3, K_4 and K_5 .

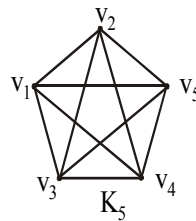
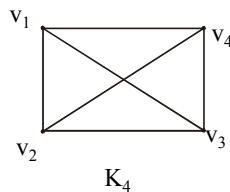
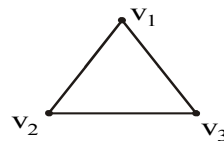
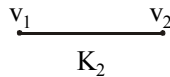
**EXERCISE:**

For the complete graph K_n , find

- (i) the degree of each vertex
- (ii) the total degrees
- (iii) the number of edges

SOLUTION:

(i) Each vertex v is connected to the other $(n-1)$ vertices in K_n ; hence $\deg(v) = n - 1$ for every v in K_n .

(ii) Each of the n vertices in K_n has degree $n - 1$; hence, the total degree in $K_n = (n - 1) + (n - 1) + \dots + (n - 1)$ n times
 $= n(n - 1)$

(iii) Each pair of vertices in K_n determines an edge, and there are $C(n, 2)$ ways of selecting two vertices out of n vertices. Hence,

Number of edges in $K_n = C(n, 2)$

$$= \frac{n(n-1)}{2}$$

Alternatively,

The total degrees in graph $K_n = 2$ (number of edges in K_n)

$$\Rightarrow n(n-1) = 2(\text{number of edges in } K_n)$$

$$\Rightarrow \text{Number of edges in } K_n = \frac{n(n-1)}{2}$$

REGULAR GRAPH:

A graph G is regular of degree k or k -regular if every vertex of G has degree k .

In other words, a graph is regular if every vertex has the same degree.

Following are some regular graphs.



(i) 0-regular



(ii) 1-regular

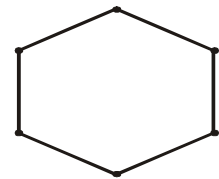
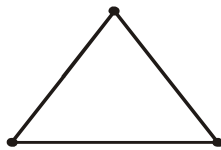

(iii) 2-regular

REMARK: The complete graph K_n is $(n-1)$ regular.

EXERCISE:

Draw two 3-regular graphs with six vertices.

SOLUTION:

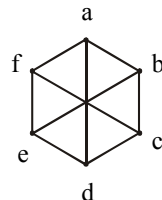
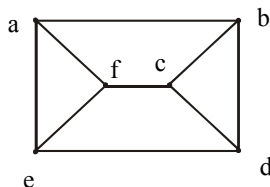

BIPARTITE GRAPH:

A bipartite graph G is a simple graph whose vertex set can be partitioned into two mutually disjoint non empty subsets A and B such that the vertices in A may be connected to vertices in B , but no vertices in A are connected to vertices in A and no vertices in B are connected to vertices in B .

The following are bipartite graphs

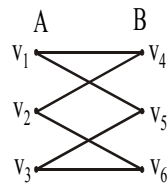
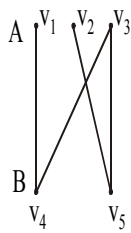

DETERMINING BIPARTITE GRAPHS:

The following labeling procedure determines whether a graph is bipartite or not.

1. Label any vertex **a**
2. Label all vertices adjacent to **a** with the label **b**.
3. Label all vertices that are adjacent to a vertex just labeled **b** with label **a**.
4. Repeat steps 2 and 3 until all vertices got a distinct label (a bipartite graph) or there is a conflict i.e., a vertex is labeled with a and b (not a bipartite graph).

EXERCISE:

Find which of the following graphs are bipartite. Redraw the bipartite graph so that its bipartite nature is evident.

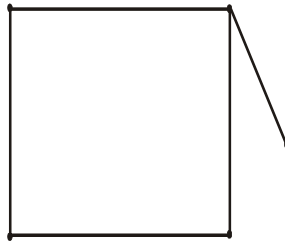
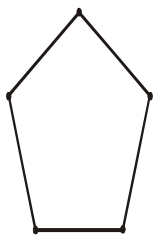

SOLUTION:

(i)

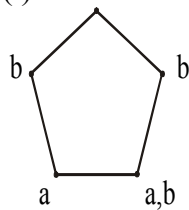

(conflict)

The graph is not bipartite.

(ii)

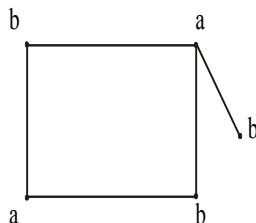

By labeling procedure, each vertex gets a distinct label. Hence the graph is bipartite. To

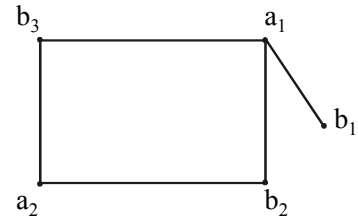

redraw the graph we mark labels a's as a_1, a_2 and b's as b_1, b_2, b_3 .
Redrawing graph with bipartite nature evident.

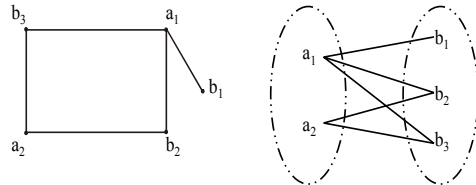

COMPLETE BIPARTITE GRAPH:

A complete bipartite graph on $(m+n)$ vertices denoted $K_{m,n}$ is a simple graph whose vertex set can be partitioned into two mutually disjoint non empty subsets A and B containing m and n vertices respectively, such that each vertex in set A is connected (adjacent) to every vertex in set B, but the vertices within a set are not connected.

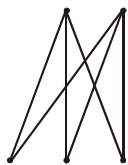

$K_{2,3}$

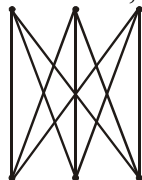

$K_{3,3}$

Lecture# 40 Paths and circuits

PATHS AND CIRCUITS

KONIGSBERG BRIDGES PROBLEM

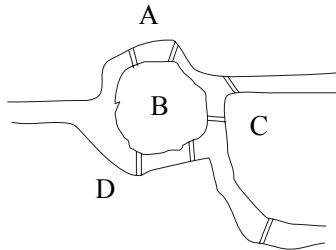

It is possible for a person to take a walk around town, starting and ending at the same location and crossing each of the seven bridges exactly once?

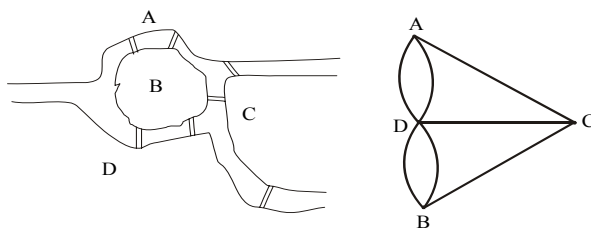

Is it possible to find a route through the graph that starts and ends at some vertex A, B, C or D and traverses each edge exactly once?

Equivalently:

Is it possible to trace this graph, starting and ending at the same point, without ever lifting your pencil from the paper?

DEFINITIONS:

Let G be a graph and let v and w be vertices in graph G .

1. WALK

A walk from v to w is a finite alternating sequence of adjacent vertices and edges of G .

Thus a walk has the form

$$v_0 e_1 v_1 e_2 \dots v_{n-1} e_n v_n$$

where the v 's represent vertices, the e 's represent edges $v_0=v$, $v_n=w$, and for all $i = 1, 2 \dots n$, v_{i-1} and v_i are endpoints of e_i .

The trivial walk from v to v consists of the single vertex v .

2. CLOSED WALK

A closed walk is a walk that starts and ends at the same vertex.

3. CIRCUIT

A circuit is a closed walk that does not contain a repeated edge. Thus a circuit is a walk of the form

$$v_0 e_1 v_1 e_2 \dots v_{n-1} e_n v_n$$

where $v_0 = v_n$ and all the $e_{i,s}$ are distinct.

4. SIMPLE CIRCUIT

A simple circuit is a circuit that does not have any other repeated vertex except the first and last.

Thus a simple circuit is a walk of the form

$$v_0 e_1 v_1 e_2 \dots v_{n-1} e_n v_n$$

where all the $e_{i,s}$ are distinct and all the $v_{j,s}$ are distinct except that $v_0 = v_n$

5. PATH

A path from v to w is a walk from v to w that does not contain a repeated edge. Thus a path from v to w is a walk of the form

$$v = v_0 e_1 v_1 e_2 \dots v_{n-1} e_n v_n = w$$

where all the $e_{i,s}$ are distinct (that is $e_i \neq e_k$ for any $i \neq k$).

6. SIMPLE PATH

A simple path from v to w is a path that does not contain a repeated vertex.

Thus a simple path is a walk of the form

$$v = v_0 e_1 v_1 e_2 \dots v_{n-1} e_n v_n = w$$

where all the $e_{i,s}$ are distinct and all the $v_{j,s}$ are also distinct (that is, $v_j \neq v_m$ for any $j \neq m$).

SUMMARY

	Repeated Edge	Repeated Vertex	Starts and Ends at Same Point
walk	allowed	Allowed	allowed
closed walk	allowed	Allowed	yes (means, where it starts also ends at that point)
circuit	no	Allowed	yes
simple circuit	no	first and last only	yes
path	no	Allowed	allowed
simple path	no	no	No

EXERCISE:

In the graph below, determine whether the following walks are paths, simple paths, closed walks, circuits, simple circuits, or are just walks.

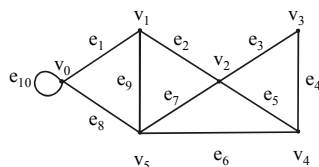

- (a) $v_1e_2v_2e_3v_3e_4v_4e_5v_2e_2v_1e_1v_0$
- (b) $v_1v_2v_3v_4v_5v_2$
- (c) $v_4v_2v_3v_4v_5v_2v_4$
- (d) $v_2v_1v_5v_2v_3v_4v_2$
- (e) $v_0v_5v_2v_3v_4v_2v_1$
- (f) $v_5v_4v_2v_1$

SOLUTION:

(a) $v_1e_2v_2e_3v_3e_4v_4e_5v_2e_2v_1e_1v_0$

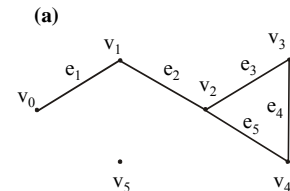

This graph starts at vertex v_1 , then goes to v_2 along edge e_2 , and moves continuously, at the end it goes from v_1 to v_0 along e_1 . Note it that the vertex v_2 and the edge e_2 is repeated twice, and starting and ending, not at the same points. Hence The graph is just a walk.

(b) $v_1v_2v_3v_4v_5v_2$

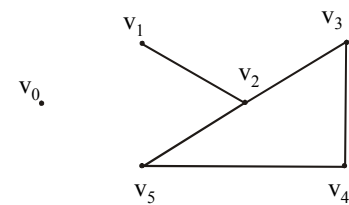

In this graph vertex v_2 is repeated twice. As no edge is repeated so the graph is a path.

(c) $v_4v_2v_3v_4v_5v_2v_4$

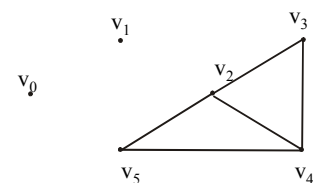

As vertices v_2 & v_4 are repeated and graph starts and ends at the same point v_4 , also the edge (i.e. e_5) connecting v_2 & v_4 is repeated, so the graph is a closed walk.

(d) $v_2v_1v_5v_2v_3v_4v_2$

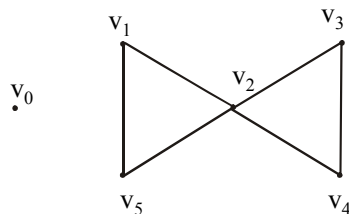

In this graph, vertex v_2 is repeated and the graph starts and end at the same vertex (i.e. at v_2) and no edge is repeated, hence the above graph is a circuit.

(e) $v_0v_5v_2v_3v_4v_2v_1$

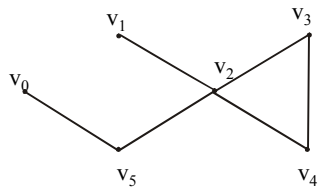

Here vertex v_2 is repeated and no edge is repeated so the graph is a path.

(f) $v_5v_4v_2v_1$

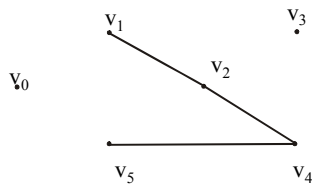

Neither any vertex nor any edge is repeated so the graph is a simple path.

CONNECTEDNESS:

Let G be a graph. Two vertices v and w of G are connected if, and only if, there is a walk from v to w . The graph G is connected if, and only if, given any two vertices v and w in G , there is a walk from v to w . Symbolically:

G is connected $\Leftrightarrow \forall$ vertices $v, w \in V(G), \exists$ a walk from v to w :

EXAMPLE:

Which of the following graphs have a connectedness?

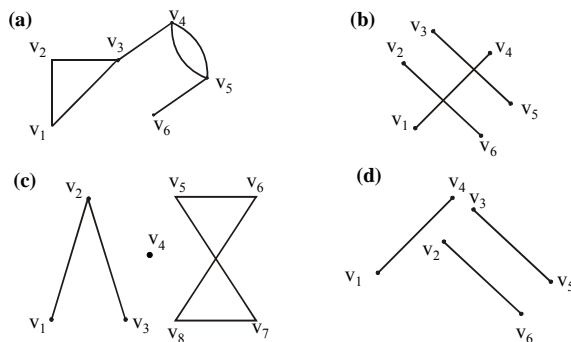

EULER CIRCUITS

DEFINITION:

Let G be a graph. An Euler circuit for G is a circuit that contains every vertex and every edge of G . That is, an Euler circuit for G is sequence of adjacent vertices and edges in G that starts and ends at the same vertex uses every vertex of G at least once, and used every edge of G exactly once.

THEOREM:

A graph G has an Euler circuit if, and only if, G is connected and every vertex of G has an even degree.

KONIGSBERG BRIDGES PROBLEM

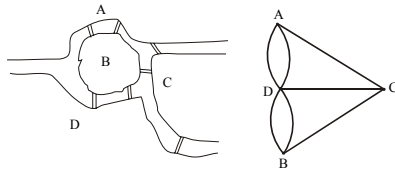

We try to solve Königsberg bridges problem by Euler method.
 Here $\text{deg}(a)=3, \text{deg}(b)=3, \text{deg}(c)=3$ and $\text{deg}(d)=5$ as the vertices have odd degree so there is no possibility of an Euler circuit.

EXERCISE:

Determine whether the following graph has an Euler circuit.

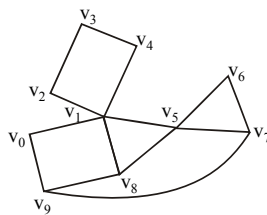

SOLUTION:

As $\text{deg}(v_1)=5$, an odd degree so the following graph has not an Euler circuit.

EXERCISE:

Determine whether the following graph has Euler circuit.

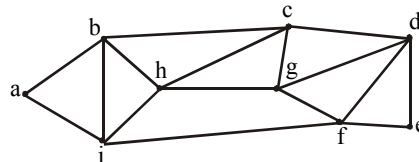

SOLUTION:

From above clearly $\text{deg}(a)=2, \text{deg}(b)=4, \text{deg}(c)=4, \text{deg}(d)=4, \text{deg}(e)=2,$
 $\text{deg}(f)=4, \text{deg}(g)=4, \text{deg}(h)=4, \text{deg}(i)=4$
 Since the degree of each vertex is even, and the graph has Euler Circuit. One such circuit is:

a b c d e f g d f i h c g h b i a

EULER PATH

DEFINITION:

Let G be a graph and let v and w be two vertices of G . An Euler path from v to w is a sequence of adjacent edges and vertices that starts at v , end and w , passes through every vertex of G at least once, and traverses every edge of G exactly once.

COROLLARY

Let G be a graph and let v and w be two vertices of G . There is an Euler path from v to w if, and only if, G is connected, v and w have odd degree and all other vertices of G have even degree.

HAMILTONIAN CIRCUITS**DEFINITION:**

Given a graph G , a Hamiltonian circuit for G is a simple circuit that includes every vertex of G . That is, a Hamiltonian circuit for G is a sequence of adjacent vertices and distinct edges in which every vertex of G appears exactly once.

EXERCISE:

Find Hamiltonian Circuit for the following graph.

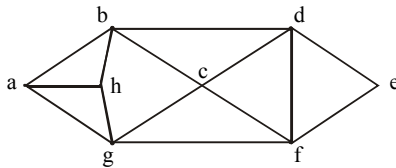
**SOLUTION:**

The Hamiltonian Circuit for the following graph is:

a b d e f c g h a

Another Hamiltonian Circuit for the following graph could be:

a b c d e f g h a

PROPOSITION:

If a graph G has a Hamiltonian circuit then G has a sub-graph H with the following properties:

1. H contains every vertex G
2. H is connected
3. H has the same number of edges as vertices
4. Every vertex of H has degree 2

EXERCISE:

Show that the following graph does not have a Hamiltonian circuit.

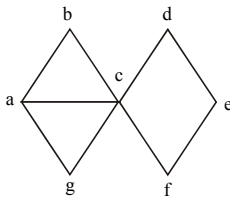

Here $\deg(c)=5$, if we remove 3 edges from vertex c then $\deg(b)< 2$, $\deg(g)< 2$ or $\deg(f)< 2, \deg(d)< 2$.

It means that this graph does not satisfy the desired properties as above, so the graph does not have a Hamiltonian circuit.

Lecture# 41 Matrix representation of graphs

MATRIX REPRESENTATIONS OF GRAPHS

MATRIX:

An $m \times n$ matrix A over a set S is a rectangular array of elements of S arranged into m rows and n columns:

$$A = \begin{bmatrix} a_{11} & a_{12} & \cdots & a_{1j} & \cdots & a_{1n} \\ a_{21} & a_{22} & \cdots & a_{2j} & \cdots & a_{2n} \\ \vdots & \vdots & & \vdots & & \vdots \\ \leftarrow i\text{th row of } A & \vdots & & \vdots & & \vdots \\ a_{i1} & a_{i2} & \cdots & a_{ij} & \cdots & a_{in} \\ \vdots & \vdots & & \vdots & & \vdots \\ a_{m1} & a_{m2} & \cdots & a_{mj} & \cdots & a_{mn} \end{bmatrix}$$

↑

jth column of A

Briefly, it is written as:

$$A = [a_{ij}]_{m \times n}$$

EXAMPLE:

$$A = \begin{bmatrix} 4 & -2 & 0 & 6 \\ 2 & -3 & 1 & 9 \\ 0 & 7 & 5 & -1 \end{bmatrix}$$

A is a matrix having 3 rows and 4 columns. We call it a 3×4 matrix, or matrix of size 3×4 (or we say that a matrix having an order 3×4).

Note it that

$a_{11} = 4$ (11 means 1st row and 1st column), $a_{12} = -2$ (12 means 1st row and 2nd column),
 $a_{13} = 0$, $a_{14} = 6$
 $a_{21} = 2$, $a_{22} = -3$, $a_{23} = 1$, $a_{24} = 9$ etc.

SQUARE MATRIX:

A matrix for which the number of rows and columns are equal is called a square matrix. A square matrix A with m rows and n columns (size $m \times n$) but $m=n$ (i.e. of order $n \times n$) has the form:

$$A = \begin{bmatrix} a_{11} & a_{12} & \cdots & a_{1i} & \cdots & a_{1n} \\ a_{21} & a_{22} & \cdots & a_{2i} & \cdots & a_{2n} \\ \vdots & \vdots & & \vdots & & \vdots \\ a_{i1} & a_{i2} & \cdots & a_{ii} & \cdots & a_{in} \\ \vdots & \vdots & & \vdots & & \vdots \\ a_{n1} & a_{n2} & \cdots & a_{ni} & \cdots & a_{nn} \end{bmatrix}$$

↗ Diagonal entries

Note:

The main diagonal of A consists of all the entries

$$a_{11}, a_{22}, a_{33}, \dots, a_{ii}, \dots, a_{nn}$$

TRANSPOSE OF A MATRIX:

The transpose of a matrix A of size $m \times n$, is the matrix denoted by A^t of size $n \times m$, obtained by writing the rows of A , in order, as columns. (Or we can say that transpose of a matrix means “write the rows instead of columns or write the columns instead of rows”). Thus if

$$A = \begin{bmatrix} a_{11} & a_{12} & \cdots & a_{1n} \\ a_{21} & a_{22} & \cdots & a_{2n} \\ \vdots & \vdots & & \vdots \\ a_{m1} & a_{m2} & \cdots & a_{mn} \end{bmatrix}, \quad \text{then } A^t = \begin{bmatrix} a_{11} & a_{21} & \cdots & a_{m1} \\ a_{12} & a_{22} & \cdots & a_{m2} \\ \vdots & \vdots & & \vdots \\ a_{1n} & a_{2n} & \cdots & a_{mn} \end{bmatrix}$$

EXAMPLE:

$$A = \begin{bmatrix} 4 & -2 & 0 & 6 \\ 2 & -3 & 1 & 9 \\ 0 & 7 & 5 & -1 \end{bmatrix}$$

Then

$$A^t = \begin{bmatrix} 4 & 2 & 0 \\ -2 & -3 & 7 \\ 0 & 1 & 5 \\ 6 & 9 & -1 \end{bmatrix}$$

SYMMETRIC MATRIX:

A square matrix $A = [a_{ij}]$ of size $n \times n$ is called symmetric if, and only if, $A^t = A$ i.e., for all $i, j = 1, 2, \dots, n$, $a_{ij} = a_{ji}$

EXAMPLE:

$$\text{Let } A = \begin{bmatrix} 1 & 3 & 7 \\ 5 & 2 & 9 \end{bmatrix}, \quad \text{and } B = \begin{bmatrix} 4 & 2 & 0 \\ 2 & -3 & 1 \\ 0 & 1 & 5 \end{bmatrix}$$

$$\text{Then } A^t = \begin{bmatrix} 1 & 5 \\ 3 & 2 \\ 7 & 9 \end{bmatrix}, \quad \text{and } B^t = \begin{bmatrix} 4 & 2 & 0 \\ 2 & -3 & 1 \\ 0 & 1 & 5 \end{bmatrix}$$

Note that $B^t = B$, so that B is a symmetric matrix.

MATRIX MULTIPLICATION:

Suppose A and B are two matrices such that the number of columns of A is equal to the number of rows of B, say A is an $m \times p$ matrix and B is a $p \times n$ matrix. Then the product of A and B, written AB, is the $m \times n$ matrix whose ij th entry is obtained by multiplying the elements of the i th row of A by the corresponding elements of the j th column of B and then adding;

$$\begin{bmatrix} a_{11} & a_{12} & \cdots & a_{1p} \\ \vdots & \vdots & & \vdots \\ a_{i1} & a_{i2} & \cdots & a_{ip} \\ \vdots & \vdots & & \vdots \\ a_{m1} & a_{m2} & \cdots & a_{mp} \end{bmatrix} \begin{bmatrix} b_{11} & \cdots & b_{1j} & \cdots & b_{1n} \\ b_{21} & \cdots & b_{2j} & \cdots & b_{2n} \\ \vdots & & & & \\ b_{p1} & \cdots & b_{pj} & \cdots & b_{pn} \end{bmatrix} = \begin{bmatrix} c_{11} & \cdots & c_{1j} & \cdots & c_{1n} \\ \vdots & & & & \\ c_{i1} & \cdots & c_{ij} & \cdots & c_{in} \\ \vdots & & & & \\ c_{m1} & \cdots & c_{mj} & \cdots & c_{mn} \end{bmatrix}$$

where

$$c_{ij} = a_{i1}b_{1j} + a_{i2}b_{2j} + \cdots + a_{ip}b_{pj} = \sum_{k=1}^p a_{ik}b_{kj}$$

REMARK:

If the number of columns of A is not equal to the number of rows of B, then the product AB is not defined.

EXAMPLE:

Find the product AB and BA of the matrices

$$A = \begin{bmatrix} 1 & 3 \\ 2 & -1 \end{bmatrix} \quad \text{and} \quad B = \begin{bmatrix} 2 & 0 & -4 \\ 3 & -2 & 6 \end{bmatrix}$$

SOLUTION:

Size of A is 2×2 and of B is 2×3 , the product AB is defined as a 2×3 matrix. But BA is not defined, because no. of columns of B = $3 \neq 2$ = no. of rows of A.

$$AB = \begin{bmatrix} 1 & 3 \\ 2 & -1 \end{bmatrix} \begin{bmatrix} 2 & 0 & -4 \\ 3 & -2 & 6 \end{bmatrix}$$

$$= \begin{bmatrix} (1)(2) + (3)(3) & (1)(0) + (3)(-2) & (1)(-4) + (3)(6) \\ (2)(2) + (-1)(3) & (2)(0) + (-1)(-2) & (2)(-4) + (-1)(6) \end{bmatrix} = \begin{bmatrix} 11 & -6 & 14 \\ 1 & 2 & -14 \end{bmatrix}$$

EXERCISE:

Find AA^t and A^tA , where

$$A = \begin{bmatrix} 1 & 2 & 0 \\ 3 & -1 & 4 \end{bmatrix}$$

SOLUTION:

A^t is obtained from A by rewriting the rows of A as columns:

$$\text{i.e. } A^t = \begin{bmatrix} 1 & 3 \\ 2 & -1 \\ 0 & 4 \end{bmatrix}$$

Now

$$AA^t = \begin{bmatrix} 1 & 2 & 0 \\ 3 & -1 & 4 \end{bmatrix} \begin{bmatrix} 1 & 3 \\ 2 & -1 \\ 0 & 4 \end{bmatrix} = \begin{bmatrix} 1+4+0 & 3-2+0 \\ 3-2+0 & 9+1+16 \end{bmatrix} = \begin{bmatrix} 5 & 1 \\ 1 & 26 \end{bmatrix}$$

and

$$\begin{aligned} A^t A &= \begin{bmatrix} 1 & 3 \\ 2 & -1 \\ 0 & 4 \end{bmatrix} \begin{bmatrix} 1 & 2 & 0 \\ 3 & -1 & 4 \end{bmatrix} \\ &= \begin{bmatrix} 1+9 & 2-3 & 0+12 \\ 2-3 & 4+1 & 0-4 \\ 0+12 & 0-4 & 0+16 \end{bmatrix} \\ &= \begin{bmatrix} 10 & -1 & 12 \\ -1 & 5 & -4 \\ 12 & -4 & 16 \end{bmatrix} \end{aligned}$$

ADJACENCY MATRIX OF A GRAPH:

Let G be a graph with ordered vertices v_1, v_2, \dots, v_n . The adjacency matrix of G is the matrix $A = [a_{ij}]$ over the set of non-negative integers such that

a_{ij} = the number of edges connecting v_i and v_j for all $i, j = 1, 2, \dots, n$.

OR

The adjacency matrix say $A = [a_{ij}]$ is also defined as

$$a_{ij} = \begin{cases} 1 & \text{if } \{v_i, v_j\} \text{ is an edge of } G \\ 0 & \text{otherwise} \end{cases}$$

EXAMPLE:

A graph with its adjacency matrix is shown.

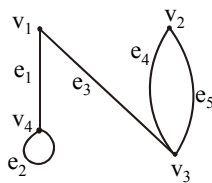

$$A = \begin{matrix} & \begin{matrix} v_1 & v_2 & v_3 & v_4 \end{matrix} \\ \begin{matrix} v_1 \\ v_2 \\ v_3 \\ v_4 \end{matrix} & \begin{bmatrix} 0 & 0 & 1 & 1 \\ 0 & 0 & 2 & 0 \\ 1 & 2 & 0 & 0 \\ 1 & 0 & 0 & 1 \end{bmatrix} \end{matrix}$$

Note that the nonzero entries along the main diagonal of A indicate the presence of loops and entries larger than 1 correspond to parallel edges.

Also note A is a symmetric matrix.

EXERCISE:

Find a graph that have the following adjacency matrix.

$$\begin{bmatrix} 0 & 2 & 0 \\ 2 & 1 & 0 \\ 0 & 0 & 1 \end{bmatrix}$$

SOLUTION:

Let the three vertices of the graph be named v_1, v_2 and v_3 . We label the adjacency matrix across the top and down the left side with these vertices and draw the graph accordingly (as from v_1 to v_2 there is a value “2”, it means that two parallel edges between v_1 and v_2 and same condition occurs between v_2 and v_1 and the value “1” represent the loops of v_2 and v_3).

	v_1	v_2	v_3
v_1	0	2	0
v_2	2	1	0
v_3	0	0	1



DIRECTED GRAPH:

A directed graph or digraph, consists of two finite sets: a set $V(G)$ of vertices and a set $D(G)$ of directed edges, where each edge is associated with an ordered pair of vertices called its end points.

If edge e is associated with the pair (v, w) of vertices, then e is said to be the directed edge from v to w and is represented by drawing an arrow from v to w .

EXAMPLE OF A DIGRAPH:

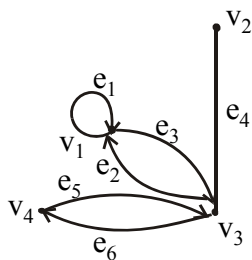

ADJACENCY MATRIX OF A DIRECTED GRAPH:

Let G be a graph with ordered vertices v_1, v_2, \dots, v_n .

The adjacency matrix of G is the matrix $A = [a_{ij}]$ over the set of non-negative integers such that

$$a_{ij} = \text{the number of arrows from } v_i \text{ to } v_j \text{ for all } i, j = 1, 2, \dots, n.$$

EXAMPLE:

A directed graph with its adjacency matrix is shown

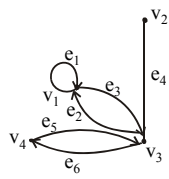

$$A = \begin{matrix} & \begin{matrix} v_1 & v_2 & v_3 & v_4 \end{matrix} \\ \begin{matrix} v_1 \\ v_2 \\ v_3 \\ v_4 \end{matrix} & \begin{bmatrix} 1 & 0 & 1 & 0 \\ 0 & 0 & 1 & 0 \\ 1 & 0 & 0 & 1 \\ 0 & 0 & 1 & 0 \end{bmatrix} \end{matrix} \quad \swarrow$$

is the adjacency matrix

EXERCISE:

Find directed graph that has the adjacency matrix

$$\begin{bmatrix} 1 & 0 & 1 & 2 \\ 0 & 0 & 1 & 0 \\ 0 & 2 & 1 & 1 \\ 0 & 1 & 1 & 0 \end{bmatrix}$$

SOLUTION:

The 4×4 adjacency matrix shows that the graph has 4 vertices say v_1, v_2, v_3 and v_4 labeled across the top and down the left side of the matrix.

$$A = \begin{matrix} & \begin{matrix} v_1 & v_2 & v_3 & v_4 \end{matrix} \\ \begin{matrix} v_1 \\ v_2 \\ v_3 \\ v_4 \end{matrix} & \begin{bmatrix} 1 & 0 & 1 & 2 \\ 0 & 0 & 1 & 0 \\ 0 & 2 & 1 & 1 \\ 0 & 1 & 1 & 0 \end{bmatrix} \end{matrix}$$

A corresponding directed graph is

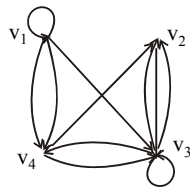

It means that a loop exists from v_1 and v_3 , two arrows go from v_1 to v_4 and two from v_3 and v_2 and one arrow go from v_1 to v_3 , v_2 to v_3 , v_3 to v_4 , v_4 to v_2 and v_3 .

THEOREM

If G is a graph with vertices v_1, v_2, \dots, v_m and A is the adjacency matrix of G , then for each positive integer n , the ij th entry of A^n = the number of walks of length n from v_i to v_j for all integers $i, j = 1, 2, \dots, n$

PROBLEM:

$$\text{Let } A = \begin{bmatrix} 1 & 1 & 2 \\ 1 & 0 & 1 \\ 2 & 1 & 0 \end{bmatrix}$$

be the adjacency matrix of a graph G with vertices v_1, v_2 , and v_3 . Find

(a) the number of walks of length 2 from v_2 to v_3

(b) the number of walks of length 3 from v_1 to v_3

Draw graph G and find the walks by visual inspection for (a)

SOLUTION:

$$(a) \quad A^2 = AA = \begin{bmatrix} 1 & 1 & 2 \\ 1 & 0 & 1 \\ 2 & 1 & 0 \end{bmatrix} \begin{bmatrix} 1 & 1 & 2 \\ 1 & 0 & 1 \\ 2 & 1 & 0 \end{bmatrix} = \begin{bmatrix} 6 & 3 & 3 \\ 3 & 2 & 2 \\ 3 & 2 & 5 \end{bmatrix} \longrightarrow \text{it shows the entry } (2,3) \text{ from } v_2 \text{ to } v_3$$

Hence, number of walks of length 2 (means “multiply matrix A two times”) from v_2 to v_3 = the entry at (2,3) of $A^2 = 2$

(b)
$$A^3 = AA^2 = \begin{bmatrix} 1 & 1 & 2 \\ 1 & 0 & 1 \\ 2 & 1 & 0 \end{bmatrix} \begin{bmatrix} 6 & 3 & 3 \\ 3 & 2 & 2 \\ 3 & 2 & 5 \end{bmatrix} = \begin{bmatrix} 15 & 9 & 15 \\ 9 & 5 & 8 \\ 15 & 8 & 8 \end{bmatrix}$$
 it shows the entry (1,3) from v_1 to v_3

Hence, number of walks of length 3 from v_1 to v_3 = the entry at (1,3) of $A^3 = 15$
Walks from v_2 to v_3 by visual inspection of graph is

$$A = \begin{bmatrix} 1 & 1 & 2 \\ 1 & 0 & 1 \\ 2 & 1 & 0 \end{bmatrix}$$

so in part (a) two walks of length 2 from v_2 to v_3 are

(i) $v_2 e_2 v_1 e_3 v_3$ (by using the above theorem).

(ii) $v_2 e_2 v_1 e_4 v_3$

INCIDENCE MATRIX OF A SIMPLE GRAPH:

Let G be a graph with vertices v_1, v_2, \dots, v_n and edges e_1, e_2, \dots, e_m . The incidence matrix of G is the matrix $M = [m_{ij}]$ of size $n \times m$ defined by

$$m_{ij} = \begin{cases} 1 & \text{if the vertex } v_i \text{ is incident on the edge } e_j \\ 0 & \text{otherwise} \end{cases}$$

EXAMPLE:

A graph with its incidence matrix is shown.

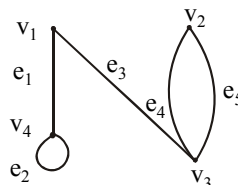

$$M = \begin{matrix} & e_1 & e_2 & e_3 & e_4 & e_5 \\ \begin{matrix} v_1 \\ v_2 \\ v_3 \\ v_4 \end{matrix} & \begin{bmatrix} 1 & 0 & 1 & 0 & 0 \\ 0 & 0 & 0 & 1 & 1 \\ 0 & 0 & 1 & 1 & 1 \\ 1 & 1 & 0 & 0 & 0 \end{bmatrix} \end{matrix}$$

REMARK:

In the incidence matrix

- Multiple edges are represented by columns with identical entries (in this matrix e_4 & e_5 are multiple edges).
- Loops are represented using a column with exactly one entry equal to 1, corresponding to the vertex that is incident with this loop and other zeros (here e_2 is only a loop).

Lecture# 42 Isomorphism of graphs

ISOMORPHISM OF GRAPHS

Here we have a graph

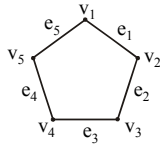

Which can also be defined as

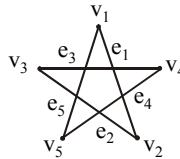

Its vertices and edges can be written as:

$$V(G) = \{v_1, v_2, v_3, v_4, v_5\}, \quad E(G) = \{e_1, e_2, e_3, e_4, e_5\}$$

Edge endpoint function is:

Edge	Endpoints
E ₁	{v ₁ , v ₂ }
E ₂	{v ₂ , v ₃ }
E ₃	{v ₃ , v ₄ }
E ₄	{v ₄ , v ₅ }
E ₅	{v ₅ , v ₁ }

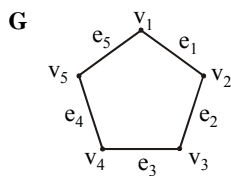

Another graph G' is

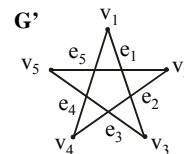

Edge endpoint function of G is:

Edge	Endpoints
e ₁	{v ₁ , v ₂ }
e ₂	{v ₂ , v ₃ }
e ₃	{v ₃ , v ₄ }
e ₄	{v ₄ , v ₅ }
e ₅	{v ₅ , v ₁ }

Edge endpoint function of G' is:

Edge	Endpoints
e ₁	{v ₁ , v ₃ }
e ₂	{v ₂ , v ₄ }
e ₃	{v ₃ , v ₅ }
e ₄	{v ₁ , v ₄ }
e ₅	{v ₂ , v ₅ }

Two graphs (G and G') that are the same except for the labeling of their vertices are not considered different.

GRAPHS OF EDGE POINT FUNCTIONS

Edge point function of G is:

Edge	Endpoints
e_1	$\{v_1, v_2\}$
e_2	$\{v_2, v_3\}$
e_3	$\{v_3, v_4\}$
e_4	$\{v_4, v_5\}$
e_5	$\{v_5, v_1\}$

Edge point function of G' is:

Edge	Endpoints
e_1	$\{v_1, v_3\}$
e_2	$\{v_2, v_4\}$
e_3	$\{v_3, v_5\}$
e_4	$\{v_1, v_4\}$
e_5	$\{v_2, v_5\}$

Note it that the graphs G and G' are looking different because in G the end points of e_1 are v_1, v_2 but in G' are v_1, v_3 etc.

Buts G' is very similar to G , if the vertices and edges of G' are relabeled by the function shown below, then G' becomes same as G :

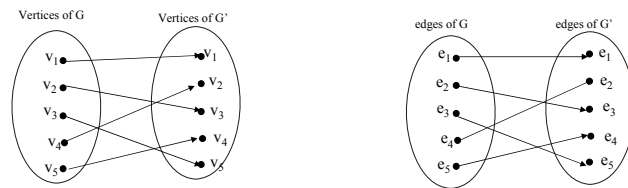

It shows that if there is one-one correspondence between the vertices of G and G' , then also one-one correspondence between the edges of G and G' .

ISOMORPHIC GRAPHS:

Let G and G' be graphs with vertex sets $V(G)$ and $V(G')$ and edge sets $E(G)$ and $E(G')$, respectively.

G is isomorphic to G' if, and only if, there exist one-to-one correspondences $g: V(G) \rightarrow V(G')$ and $h: E(G) \rightarrow E(G')$ that preserve the edge-endpoint functions of G and G' in the sense that for all $v \in V(G)$ and $e \in E(G)$,

v is an endpoint of $e \Leftrightarrow g(v)$ is an endpoint of $h(e)$.

EQUIVALENCE RELATION:

Graph isomorphism is an equivalence relation on the set of graphs.

1. Graphs isomorphism is Reflexive (It means that the graph should be isomorphic to itself).
2. Graphs isomorphism is Symmetric (It means that if G is isomorphic to G' then G' is also isomorphic to G).
3. Graphs isomorphism is Transitive (It means that if G is isomorphic to G' and G' is isomorphic to G'' , then G is isomorphic to G'').

ISOMORPHIC INVARIANT:

A property P is called an isomorphic invariant if, and only if, given any graphs G and G', if G has property P and G' is isomorphic to G, then G' has property P.

THEOREM OF ISOMORPHIC INVARIANT:

Each of the following properties is an invariant for graph isomorphism, where n, m and k are all non-negative integers, if the graph:

1. has n vertices.
2. has m edges.
3. has a vertex of degree k.
4. has m vertices of degree k.
5. has a circuit of length k.
6. has a simple circuit of length k.
7. has m simple circuits of length k.
8. is connected.
9. has an Euler circuit.
10. has a Hamiltonian circuit.

DEGREE SEQUENCE:

The degree sequence of a graph is the list of the degrees of its vertices in non-increasing order.

EXAMPLE:

Find the degree sequence of the following graph.

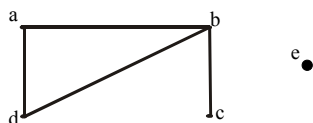
**SOLUTION:**

Degree of a = 2, Degree of b = 3, Degree of c = 1,
Degree of d = 2, Degree of e = 0

By definition, degree of the vertices of a given graph should be in decreasing (non-increasing) order.

Therefore Degree sequence is: 3, 2, 2, 1, 0

GRAPH ISOMORPHISM FOR SIMPLE GRAPHS:

If G and G' are simple graphs (means the "graphs which have no loops or parallel edges") then G is isomorphic to G' if, and only if, there exists a one-to-one correspondence (1-1 and onto function) g from the vertex set V(G) of G to the vertex set

V(G') of G' that preserves the edge-endpoint functions of G and G' in the sense that for all vertices u and v of G,

$\{u, v\}$ is an edge in G \Leftrightarrow $\{g(u), g(v)\}$ is an edge in G'.

OR

You can say that with the property of one-one correspondence, u and v are adjacent in graph G \Leftrightarrow if g(u) and g(v) are adjacent in G'.

Note:

It should be noted that unfortunately, there is no efficient method for checking that whether two graphs are isomorphic (methods are there but take so much time in calculations). Despite that there is a simple condition. Two graphs are isomorphic if they have the same number of vertices (as there is a 1-1 correspondence between the vertices of

both the graphs) and the same number of edges(also vertices should have the same degree.

EXERCISE:

Determine whether the graph G and G' given below are isomorphic.

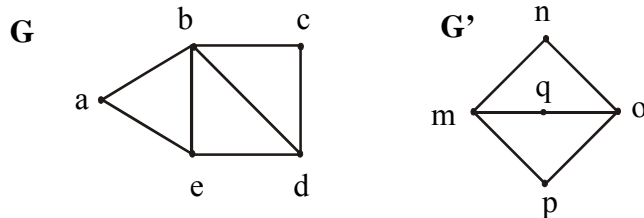

SOLUTION:

As both the graphs have the same number of vertices. But the graph G has 7 edges and the graph G' has only 6 edges. Therefore the two graphs are not isomorphic.

Note: As the edges of both the graphs G and G' are not same then how the one-one correspondence is possible, that the reason the graphs G and G' are not isomorphic.

EXERCISE:

Determine whether the graph G and G' given below are isomorphic.

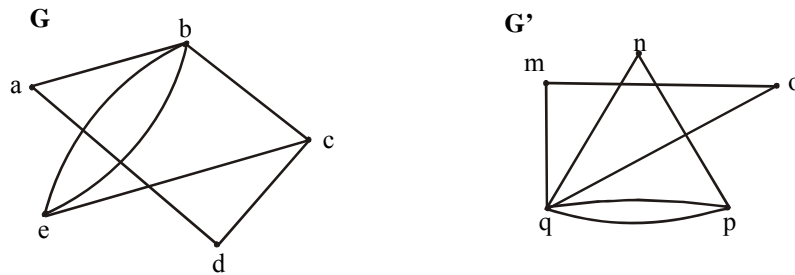

SOLUTION:

Both the graphs have 5 vertices and 7 edges. The vertex q of G' has degree 5. However G does not have any vertex of degree 5 (so one-one correspondence is not possible). Hence, the two graphs are not isomorphic.

EXERCISE:

Determine whether the graph G and G' given below are isomorphic.

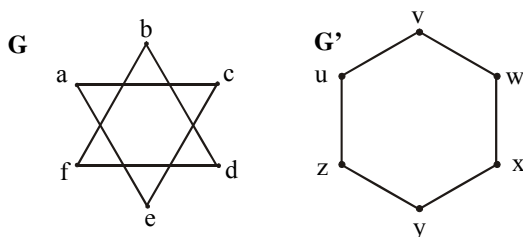

SOLUTION:

Clearly the vertices of both the graphs G and G' have the same degree (i.e. "2") and having the same number of vertices and edges but isomorphism is not possible. As the graph G' is a connected graph but the graph G is not connected due to have two components (eca and bdf). Therefore the two graphs are non isomorphic.

EXERCISE:

Determine whether the graph G and G' given below are isomorphic.

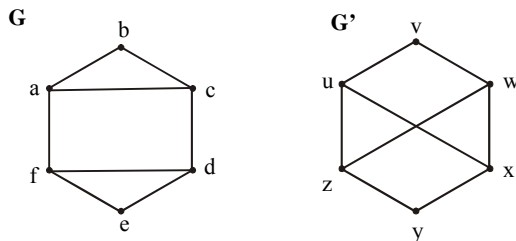
**SOLUTION:**

Clearly G has six vertices, G' also has six vertices. And the graph G has two simple circuits of length 3; one is $abca$ and the other is $defd$. But G' does not have any simple circuit of length 3 (as one simple circuit in G' is $uxvw$ of length 4). Therefore the two graphs are non-isomorphic.

Note: A simple circuit is a circuit that does not have any other repeated vertex except the first and last.

EXERCISE:

Determine whether the graph G and G' given below are isomorphic.

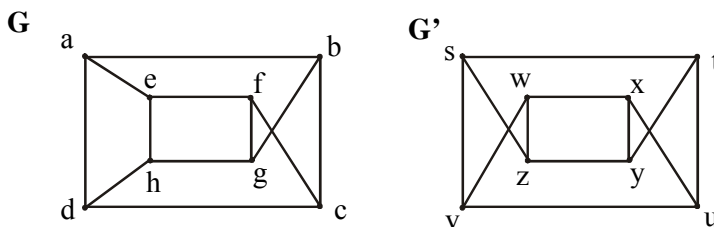
**SOLUTION:**

Both the graph G and G' have 8 vertices and 12 edges and both are also called regular graph (as each vertex has degree 3). The graph G has two simple circuits of length 5; $abcfea$ (i.e. starts and ends at a) and $cdhgfc$ (i.e. starts and ends at c). But G' does not have any simple circuit of length 5 (it has simple circuit $tyxut, vwxuv$ of length 4 etc). Therefore the two graphs are non-isomorphic.

EXERCISE:

Determine whether the graph G and G' given below are isomorphic.

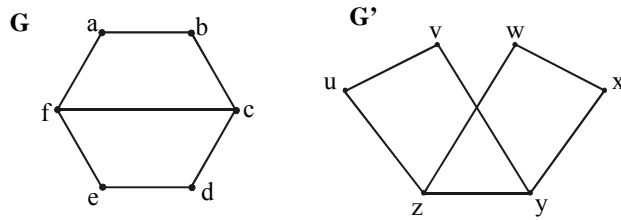
**SOLUTION:**

We note that all the isomorphism invariants seems to be true.

We shall prove that the graphs G and G' are isomorphic.

Here G has four vertices of degree “2” and two vertices of degree “3”. Similar case in G' . Also G and G' have circuits of length 4. As a is adjacent to b and f in graph G . In graph G' u is adjacent to v and z . And as a and u has degree 2 so both are mapped. And b mapped with v , f mapped with z (as both have the same degree also a is adjacent to f and u is to z), and as we move further we get the 1-1 correspondence.

Define a function $f: V(G) \rightarrow V(G')$ as follows.

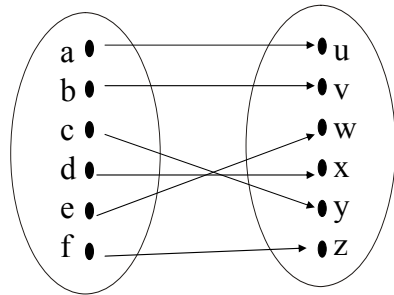

Clearly the above function is one and onto that is a bijective mapping. Note that I write the above mapping by keeping in mind the invariants of isomorphism as well as the fact that the mapping should preserve edge end point function. Also you should note that the mapping is not unique.

f is clearly a bijective function. The fact that f preserves the edge endpoint functions of G and G' is shown below.

Edges of G	Edges of G'
$\{a, b\}$	$\{u, v\} = \{g(a), g(b)\}$
$\{b, c\}$	$\{v, y\} = \{g(b), g(c)\}$
$\{c, d\}$	$\{y, x\} = \{g(c), g(d)\}$
$\{d, e\}$	$\{x, w\} = \{g(d), g(e)\}$
$\{e, f\}$	$\{w, z\} = \{g(e), g(f)\}$
$\{a, f\}$	$\{u, z\} = \{g(a), g(f)\}$

$\{c, f\}$	$\{y, z\} = \{g(c), g(f)\}$

ALTERNATIVE SOLUTION:

We shall prove that the graphs G and G' are isomorphic. Define a function $f: V(G) \rightarrow V(G')$ as follows.

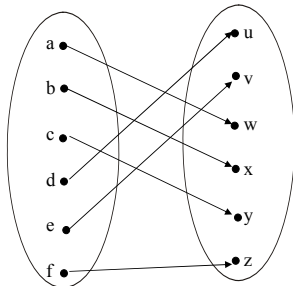
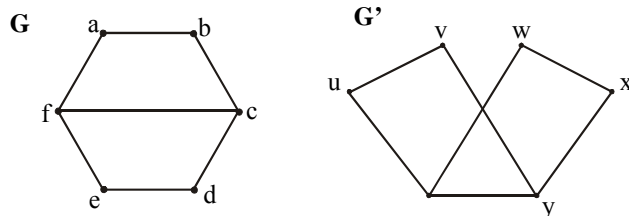

EXERCISE:

Determine whether the graph G and G' given below are isomorphic.

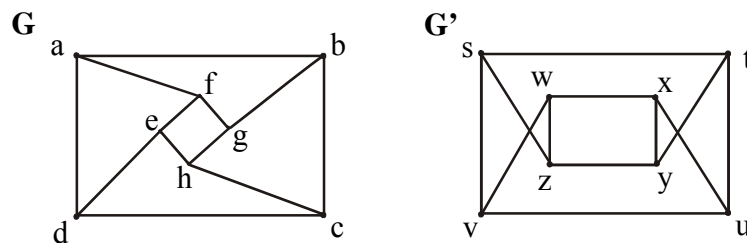

SOLUTION:

We shall prove that the graphs G and G' are isomorphic. Clearly the isomorphism invariants seems to be true between G and G' .

Define a function $f: V(G) \rightarrow V(G')$ as follows.

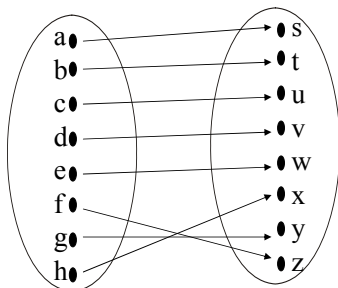

f is clearly a bijective function (as it satisfies conditions the one-one and onto function clearly). The fact that f preserves the edge endpoint functions of G and G' is shown below.

Edges of G	Edges of G'
$\{a, b\}$	$\{s, t\} = \{f(a), f(b)\}$
$\{b, c\}$	$\{t, u\} = \{f(b), f(c)\}$
$\{c, d\}$	$\{u, v\} = \{f(c), f(d)\}$
$\{a, d\}$	$\{s, v\} = \{f(a), f(d)\}$
$\{a, f\}$	$\{s, z\} = \{f(a), f(f)\}$
$\{b, g\}$	$\{t, y\} = \{f(b), f(g)\}$
$\{c, h\}$	$\{u, x\} = \{f(c), f(h)\}$
$\{d, e\}$	$\{v, w\} = \{f(d), f(e)\}$
$\{e, f\}$	$\{w, z\} = \{f(e), f(f)\}$
$\{f, g\}$	$\{z, y\} = \{f(f), f(g)\}$
$\{g, h\}$	$\{y, x\} = \{f(g), f(h)\}$
$\{h, e\}$	$\{x, w\} = \{f(h), f(e)\}$

EXERCISE:

Find all non isomorphic simple graphs with three vertices.

SOLUTION:

There are four simple graphs with three vertices as given below (which are non-isomorphic simple graphs).

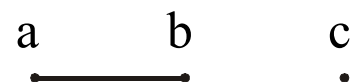
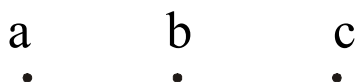

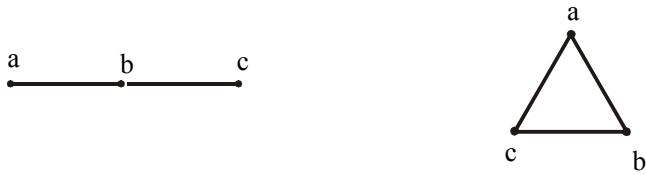
**EXERCISE:**

Find all non isomorphic simple connected graphs with three vertices.

SOLUTION:

There are two simple connected graphs with three vertices as given below (which are non-isomorphic connected simple graphs).

**EXERCISE:**

Find all non isomorphic simple connected graphs with four vertices.

SOLUTION:

There are six simple connected graphs with four vertices as given below.

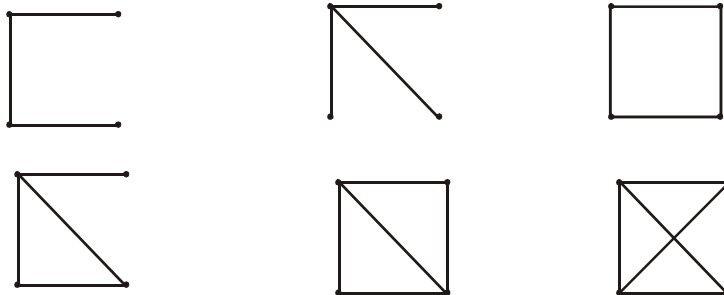

Lecture# 43 Planar graphs

PLANAR GRAPHS GRAPH COLORING

In this lecture, we will study that whether any graph can be drawn in the plane (means “a flat surface”) without crossing any edges.

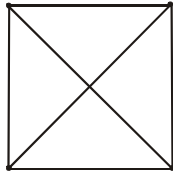

It is a graph on 4 vertices and written as K_4 . Each vertex is connected to every other vertex.

Note it that here edges are crossed. Also the above graph can also be drawn as

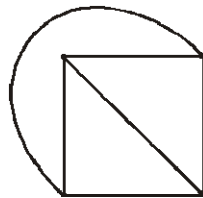

In this graph, note it that each vertex is connected to every other vertex, but no edge is crossed.

Note: The graphs shown above are complete graphs with four vertices (denoted by K_4).

DEFINITION:

A graph is called planar if it can be drawn in the plane without any edge crossed (crossing means the intersection of lines). Such a drawing is called a plane drawing of the graph.

OR

You can say that a graph is called planar in which the graph crossing number is “0”.

EXAMPLES:

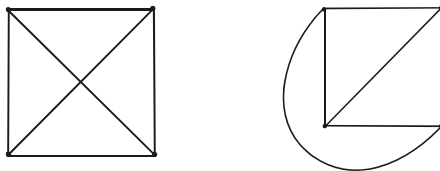

The graphs given above are planar .In the first figure edges are crossed but it can be redrawn in second figure where edges are not crossed, so called planar.

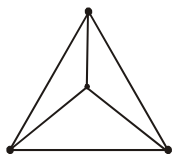

It is also a graph on 4 vertices (written as K_4) with no edge crossed, hence called planar.

Note: The graphs given above are also complete graphs (except second; are those where each vertex is connected to every other vertex) on 4 vertices and is written as K_4 .

Note: Complete graphs are planar only for $n \leq 4$.

EXAMPLE:

Show that the graph below is planar.

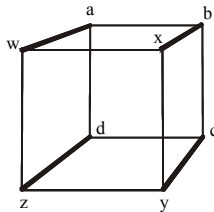

SOLUTION:

This graph has 8 vertices and 12 edges, and is called **3-cube** and is denoted Q_3 .

The above representation includes many "edge crossing." A plane drawing of the graph in which no two edges cross is possible and shown below.

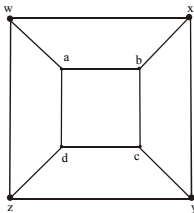

EXERCISE:

Determine whether the graph below is planar. If so, draw it so that no edges cross.

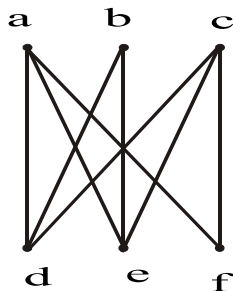

SOLUTION:

The graph given above is bipartite graph denoted by $K_{3,3}$. It also has a circuit afcebda. This graph can be re-drawn as

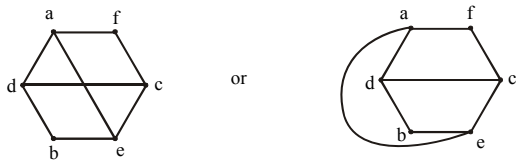

Hence the given graph is planar

THEOREM:

Show that $K_{3,3}$ is not planar.

PROOF:

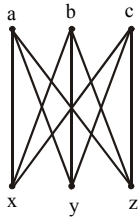

Clearly it is a complete bipartite graph (means bipartite graph, but the vertices within a set are not connected) denoted by $K_{3,3}$. Now $K_{3,3}$ can be re-drawn as

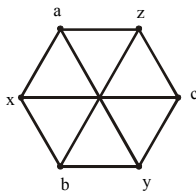

We re-draw the edge ay so that it does not cross any other edge like that.

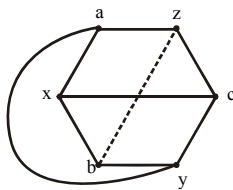

Note it that bz cannot be drawn without crossings. Hence, $K_{3,3}$ is not planar.

Similar if ay can be drawn inside (i.e drawn with crossing) and bz drawn outside, then same result exists.

THEOREM:

Show that K_5 is non-planar.

PROOF:

Graph K_5 (means a “complete graph” in which every vertex is connected to every other vertex) can be drawn as

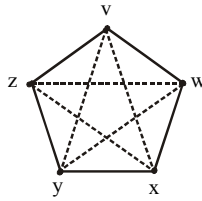

To show that K_5 is non-planar, it can be re-drawn as

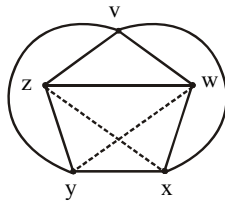

But still edges wy and zx contain the lines which crossed each other. Hence called non-planar.

DEFINITION:

A plane drawing of a planar graph divides the plane into regions, including an unbounded region, called **faces**.

The unbounded region is called the **infinite face**.

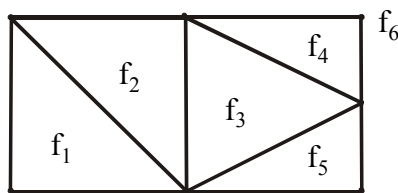

Here we have 6 faces, 7 vertices and 10 edges. f_6 is the unbounded region or called the infinite face because f_6 is outside of the graph.

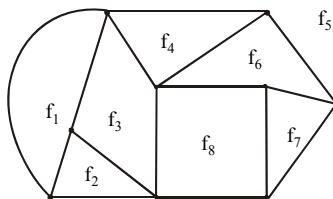

In this graph, it has 8 faces, 9 vertices and 14 edges. Here f_5 is the infinite face or unbounded region.

EULER'S FORMULA

THEOREM:

Let G be a connected planar simple graph with e edges and v vertices. Let f be the number of faces in a plane drawing of G . Then

$$f = e - v + 2$$

EXERCISE:

Suppose that a connected planar simple graph has 30 edges. If a plane drawing of this graph has 20 faces, how many vertices does this graph have?

SOLUTION:

Given that $e = 30$, and $f = 20$. Substituting these values in the Euler's Formula $f = e - v + 2$, we get

$$20 = 30 - v + 2$$

Hence,

$$v = 30 - 20 + 2 = 12$$

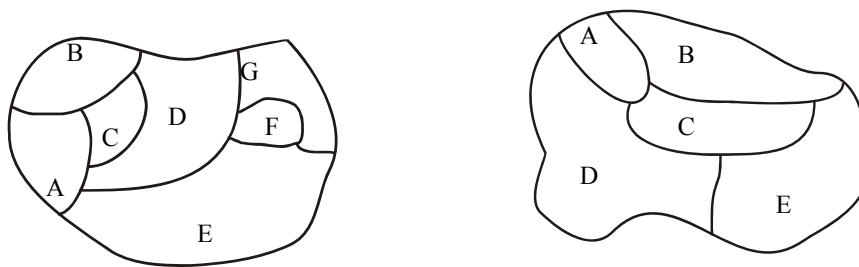
GRAPH COLORING

We also have to face many problems in the form of maps (maps like the parts of the world), which have generated many results in graph theory. Note it that in any graph, many regions are there, but two adjacent regions can't have the same color. And we have to choose a small number of color whenever possible.

Given two graphs above, our problem is to determine the least number of colors that can be used to color the map so that no adjacent regions have the same color.

In the first map given above, 4 colors are necessary, but three colors are not enough. In the second graph, 3 colors are necessary but 2 colors are not enough.

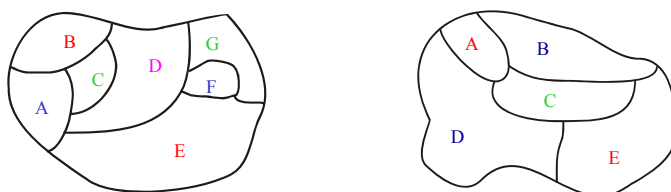

As in the 1st graph, four colors (red, pink, green, blue) are used like that adjacent regions not have the same color. In 2nd graph, three colors (red, blue, green) are used in the same manner.

HOW TO DRAW A GRAPH FROM A MAP:

1. Each map in the plane can be represented by a graph.
2. Each region is represented by a vertex (in 1st map as there are 7 regions, so 7 vertices are used in drawing a graph, similarly we can see 2nd map).

3. If the regions connected by these vertices have the common border, then edge connect two vertices.
 4. Two regions that touch at only one point are not adjacent.
- So apply these rules, we have (first graph drawn from first map given above, second graph from second map).

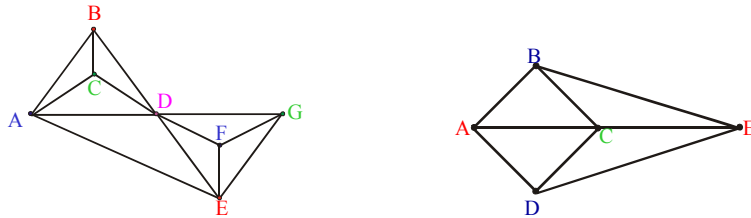

DEFINITION:

1. A **coloring** of a **simple graph** is the assignment of a color to each vertex of the graph so that no two adjacent vertices are assigned the same color.
2. The **chromatic number** of a graph is the least (minimum) number of colors for coloring of this graph.

EXAMPLE:

What is the chromatic number of the graphs G and H shown below?

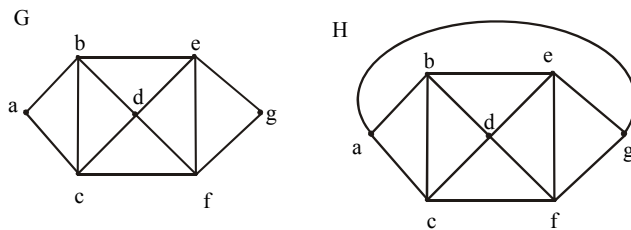

SOLUTION:

Clearly the chromatic number of G is 3 and chromatic number of H is 4 (by using the above definition).

In graph G,

As vertices a, b and c are adjacent to each other so assigned different colors. So we assign red color to vertex a, blue to b and green to vertex c. Then no more colors we choose (due to above definition). Now vertex d must be colored red because it is adjacent to vertex b (with blue color) and c (with green color). And e must be colored green because it is adjacent to vertex b (blue color) and vertex d (red color). And f must be colored blue as it is adjacent to red and green color. At last, vertex g must be colored red as it is adjacent to green and blue color.

Same process is used in Graph H.

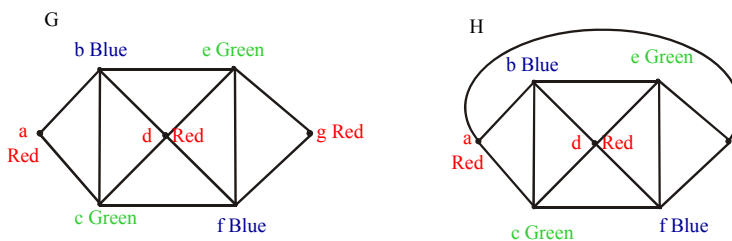

THE FOUR COLOR THEOREM:

The chromatic number of a simple planar graph is no greater than four.

APPLICATION OF GRAPH COLORING**EXAMPLE:**

Suppose that a chemist wishes to store five chemicals a , b , c , d and e in various areas of a warehouse. Some of these chemicals react violently when in contact, and so must be kept in separate areas. In the following table, an asterisk indicates those pairs of chemicals that must be separated. How many areas are needed?

	a	b	c	d	e
a	–	*	*	*	–
b	*	–	*	*	*
c	*	*	–	*	–
d	*	*	–	–	*
e	–	*	*	*	–

SOLUTION:

We draw a graph whose vertices correspond to the five chemicals, with two vertices adjacent whenever the corresponding chemicals are to be kept apart.

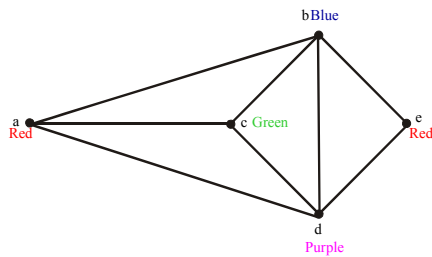

Clearly the chromatic number is 4 and so four areas are needed.

Lecture# 44 Trees

TREES

APPLICATION AREAS:

Trees are used to solve problems in a wide variety of disciplines. In computer science trees are employed to

- 1) construct efficient algorithms for locating items in a list.
- 2) construct networks with the least expensive set of telephone lines linking distributed computers.
- 3) construct efficient codes for storing and transmitting data.
- 4) model procedures that are carried out using a sequence of decisions, which are valuable in the study of sorting algorithms.

TREE:

A tree is a connected graph that does not contain any non-trivial circuit. (i.e. it is circuit-free).

A trivial circuit is one that consists of a single vertex.

Examples of tree are

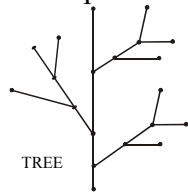

•
TREE

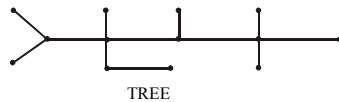

EXAMPLES OF NON TREES

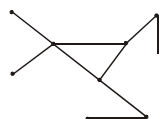

(a) Graph with a circuit



(b) Disconnected graph



(c) Graph with a circuit

In graph (a), there exists circuit, so not a tree.

In graph (b), there exists no connectedness, so not a tree.

In graph (c), there exists a circuit (also due to loop), so not a tree (because trees have to be a circuit free).

SOME SPECIAL TREES

1. TRIVIAL TREE:

A graph that consists of a single vertex is called a trivial tree or degenerate tree.

2. EMPTY TREE

A tree that does not have any vertices or edges is called an empty tree.

3. FOREST

A graph is called a forest if, and only if, it is circuit-free.

OR "Any non-connected graph that contains no circuit is called a forest."

Hence, it clears that the connected components of a forest are trees.

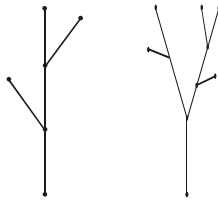

A forest

As in both the graphs above, there exists no circuit, so called forest.

PROPERTIES OF TREES:

1. A tree with n vertices has $n - 1$ edges (where $n \geq 0$).
2. Any connected graph with n vertices and $n - 1$ edges is a tree.
3. A tree has no non-trivial circuit; but if one new edge (but no new vertex) is added to it, then the resulting graph has exactly one non-trivial circuit.
4. A tree is connected, but if any edge is deleted from it, then the resulting graph is not connected.
5. Any tree that has more than one vertex has at least two vertices of degree 1.
6. A graph is a tree iff there is a unique path between any two of its vertices.

EXERCISE:

Explain why graphs with the given specification do not exist.

1. Tree, twelve vertices, fifteen edges.
2. Tree, five vertices, total degree 10.

SOLUTION:

1. Any tree with 12 vertices will have $12 - 1 = 11$ edges, not 15.
2. Any tree with 5 vertices will have $5 - 1 = 4$ edges.

$$\begin{aligned} \text{Since, total degree of graph} &= 2 (\text{No. of edges}) \\ &= 2(4) = 8 \end{aligned}$$

Hence, a tree with 5 vertices would have a total degree 8, not 10.

EXERCISE:

Find all non-isomorphic trees with four vertices.

SOLUTION:

Any tree with four vertices has $(4-1=3)$ three edges. Thus, the total degree of a tree with 4 vertices must be 6 [by using $\text{total degree} = 2(\text{total number of edges})$].

Also, every tree with more than one vertex has at least two vertices of degree 1, so the only possible combinations of degrees for the vertices of the trees are 1, 1, 1, 3 and 1, 1, 2, 2.

The corresponding trees (clearly non-isomorphic, by definition) are

**EXERCISE:**

Find all non-isomorphic trees with five vertices.

SOLUTION:

There are three non-isomorphic trees with five vertices as shown (where every tree with five vertices has $5-1=4$ edges).

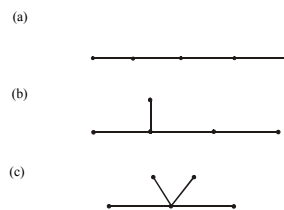

In part (a), tree has 2 vertices of degree '1' and 3 vertices of degree '2'.

In part (b), 3 vertices have degree '1', 1 has degree '2' and 1 vertex has degree '3'.

In part (c), possible combinations of degree are 1, 1, 1, 1, 4.

EXERCISE:

Draw a graph with six vertices, five edges that is not a tree.

SOLUTION:

Two such graphs are:

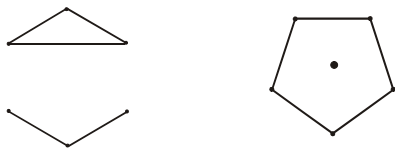

First graph is not a tree; because it is not connected also there exists a circuit.

Similarly, second graph not a tree.

DEFINITION:

A vertex of degree 1 in a tree is called a *terminal vertex* or a leaf and a vertex of degree greater than 1 in a tree is called an *internal vertex* or a branch vertex.

EXAMPLE:

The terminal vertices of the tree are v_1, v_2, v_5, v_6 and v_8 and internal vertices are v_3, v_4, v_7 .

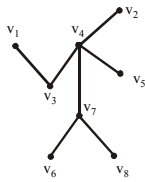
**ROOTED TREE:**

A **rooted tree** is a tree in which one vertex is distinguished from the others and is called the **root**.

The **level** of a vertex is the number of edges along the unique path between it and the root.

The **height** of a rooted tree is the maximum level to any vertex of the tree.

The **children** of any internal vertex v are all those vertices that are adjacent to v and are one level farther away from the root than v .

If w is a **child** of v , then v is called the **parent** of w .

Two vertices that are both children of the same parent are called **siblings**.

Given vertices v and w , if v lies on the unique path between w and the root, then v is an **ancestor** of w and w is a **descendant** of v .

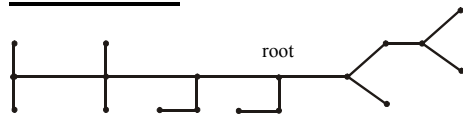
EXAMPLE:

We redraw the tree as and see what the relations are

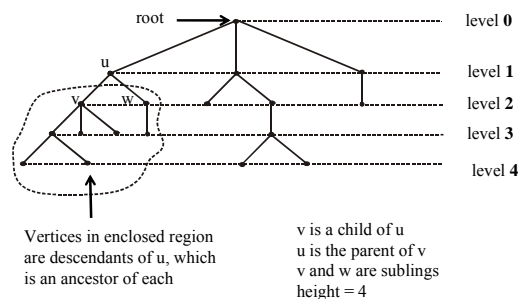
**EXERCISE:**

Consider the rooted tree shown below with root v_0

- What is the level of v_8 ?
- What is the level of v_9 ?
- What is the height of this tree?
- What are the children of v_{10} ?
- What are the siblings of v_1 ?
- What are the descendants of v_{12} ?

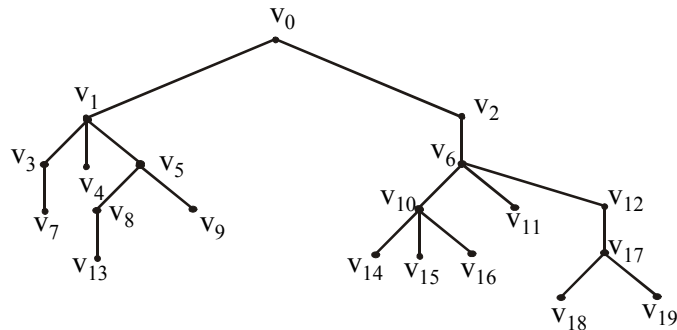
**SOLUTION:**

As we know that “Level means

the total number of edges along the unique path between it and the root”.

(a). As v_0 is the root so the level of v_8 (from the root v_0 along the unique path) is 3, because it covers the 3 edges.

(b). The level of v_0 is 0 (as no edge cover from v_0 to v_0).

(c). The height of this tree is 5.

Note: As levels are 0, 1, 2, 3, 4, 5 but to find height we have to take the maximum level.

(d). The children of v_{10} are v_{14} , v_{15} and v_{16} .

(e). The siblings of v_1 are v_3 , v_4 , and v_5 .

(f). The descendants of v_{12} are v_{17} , v_{18} , and v_{19} .

BINARY TREE

A *binary tree* is a rooted tree in which every internal vertex has at most two children.

Every child in a binary tree is designated either a left child or a right child (but not both).

A *full binary tree* is a binary tree in which each internal vertex has exactly two children.

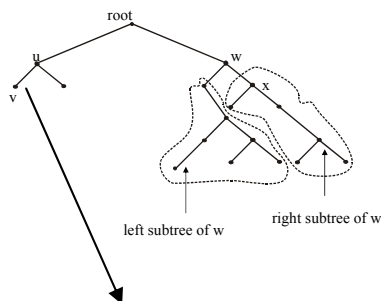
EXAMPLE:

v is the left child of u .

THEOREMS:

1. If k is a positive integer and T is a full binary tree with k internal vertices, then T has a total of $2k + 1$ vertices and has $k + 1$ terminal vertices.

2. If T is a binary tree that has t terminal vertices and height h , then $t \leq 2^h$
Equivalently,

$$\log_2 t \leq h$$

Note: The maximum number of terminal vertices of a binary tree of height h is 2^h .

EXERCISE:

Explain why graphs with the given specification do not exist.

1. full binary tree, nine vertices, five internal vertices.
2. binary tree, height 4, eighteen terminal vertices.

SOLUTION:

1. Any full binary tree with five internal vertices has six terminal vertices, for a total of eleven vertices (according to $2(5) + 1 = 11$), not nine vertices in all.

OR

As total vertices $= 2k + 1 = 9$

$\Rightarrow k = 4$ (internal vertices)

but given internal vertices $= 5$, which is a contradiction.

Thus there is no full binary tree with the given properties.

2. Any binary tree of height 4 has at most $2^4 = 16$ terminal vertices.

Hence, there is no binary tree that has height 4 and eighteen terminal vertices.

EXERCISE:

Draw a full binary tree with seven vertices.

SOLUTION:

Total vertices $= 2k + 1 = 7$ (by using the above theorem)

$$\Rightarrow k = 3$$

Hence, total number of internal vertices (i.e. a vertex of degree greater than 1) $= k = 3$

and total number of terminal vertices (i.e. a vertex of degree 1 in a tree) $= k + 1 = 3 + 1 = 4$

Hence, a full binary tree with seven vertices is

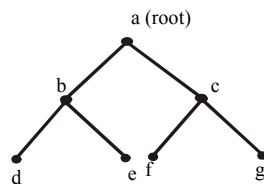

EXERCISE:

Draw a binary tree with height 3 and having seven terminal vertices.

SOLUTION:

Given height= $h=3$

Any binary tree with height 3 has atmost $2^3=8$ terminal vertices.

But here terminal vertices are 7

and Internal vertices= $k=6$ so binary tree exists and is as follows:

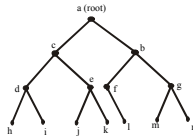
**REPRESENTATION OF ALGEBRAIC EXPRESSIONS BY BINARY TREES**

Binary trees are specially used in computer science to represent algebraic expression with Arbitrary nesting of balanced parentheses.

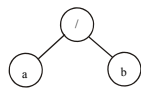

Binary tree for a/b

The above figure represents the expression a/b . Here the operator ($/$) is the root and a and b are the left and right children.

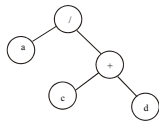

Binary tree for $a/(c+d)$

The second figure represents the expression $a/(c+d)$. Here the operator ($/$) is the root. Here the terminal vertices are variables (here a , c and d), and the internal vertices are arithmetic operators ($+$ and $/$).

EXERCISE:

Draw a binary tree to represent the following expression
 $a/(b-c.d)$

SOLUTION:

Note that the internal vertices are arithmetic operators, the terminal vertices are variables and the operator at each vertex acts on its left and right sub trees in left-right order.

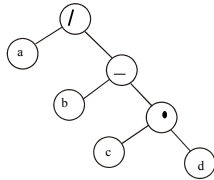

Lecture# 45 Spanning Trees

SPANNING TREES:

Suppose it is required to develop a system of roads between six major cities.

A survey of the area revealed that only the roads shown in the graph could be constructed.

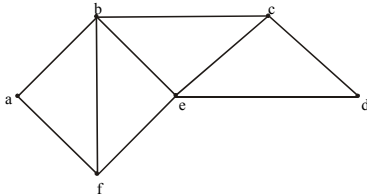

For economic reasons, it is desired to construct the least possible number of roads to connect the six cities.

One such set of roads is

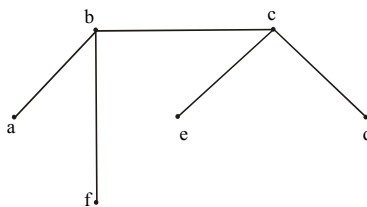

Note that the subgraph representing these roads is a tree, it is connected & circuit-free (six vertices and five edges)

SPANNING TREE:

A spanning tree for a graph G is a subgraph of G that contains every vertex of G and is a tree.

REMARK:

1. Every connected graph has a spanning tree.
2. A graph may have more than one spanning trees.
3. Any two spanning trees for a graph have the same number of edges.
4. If a graph is a tree, then its only spanning tree is itself.

EXERCISE:

Find a spanning tree for the graph below:

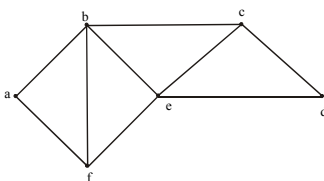

SOLUTION:

The graph has 6 vertices (a, b, c, d, e, f) & 9 edges so we must delete $9 - 6 + 1 = 4$ edges (as we have studied in lecture 44 that a tree of vertices n has $n-1$ edges). We delete an edge in each cycle.

1. Delete af 2. Delete fe
3. Delete be 4. Delete ed

Note it that we can construct road from vertex a to b, but can't go from "a to e", also from "a to d" and from "a to c", because there is no path available.

The associated spanning tree is

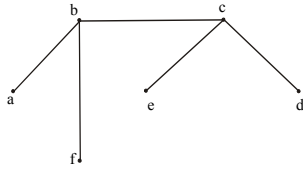

EXERCISE:

Find all the spanning trees of the graph given below.

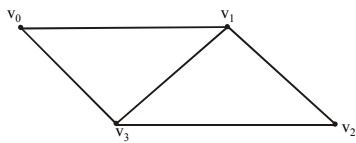

SOLUTION:

The graph has $n = 4$ vertices and $e = 5$ edges. So we must delete $e - v + 1 = 5 - 4 + 1 = 2$ edges from the cycles in the graph to obtain a spanning tree.

(1) Delete v_0v_1 & v_1v_2 to get

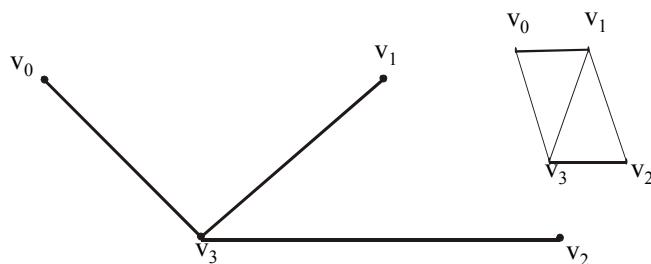

(2) Delete v_0v_1 & v_1v_3 to get

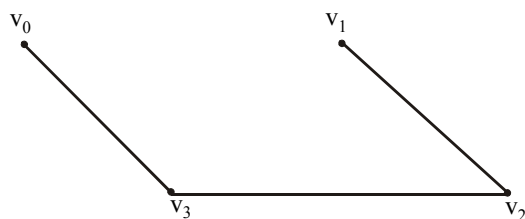

(3) Delete v_0v_1 & v_2v_3 to get

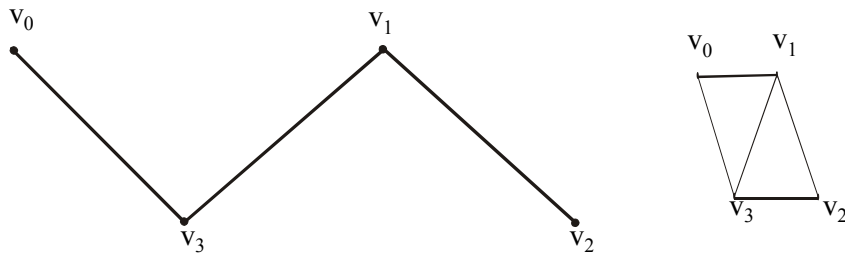

(4) Delete v_0v_3 & v_1v_2 to get

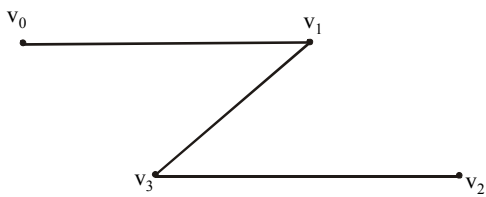

(5) Delete v_0v_3 & v_1v_3 to get

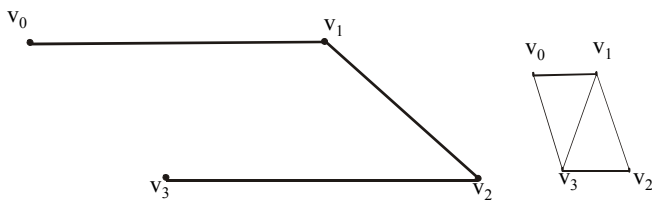

(6) Delete v_0v_3 & v_2v_3 to get

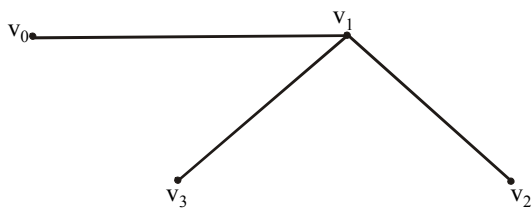

(7) Delete v_1v_3 & v_1v_2 to get

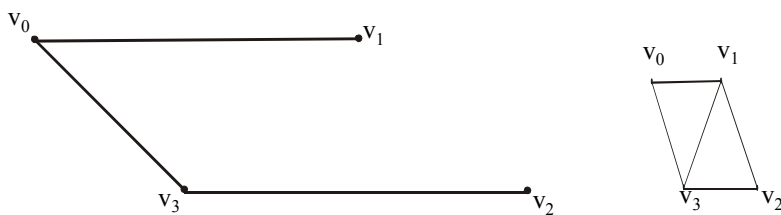

(8) Delete v_1v_3 & v_2v_3 to get

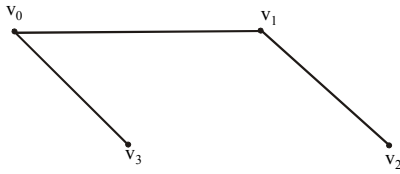

EXERCISE:

Find a spanning tree for each of the following graphs.

(a) $k_{1,5}$ (b) k_4

SOLUTION:

(a). $k_{1,5}$ represents a complete bipartite graph on (1,5) vertices, drawn below:

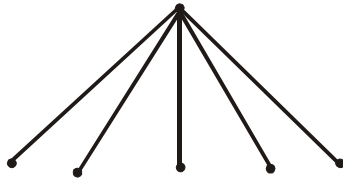

Clearly the graph itself is a tree (six vertices and five edges). Hence the graph is itself a spanning tree.

(b) k_4 represents a complete graph on four vertices.

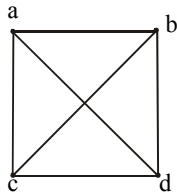

Now

number of vertices = $n = 4$ and number of edges = $e = 6$

Hence we must remove

$$e - v + 1 = 6 - 4 + 1 = 3$$

edges to obtain a spanning tree.

Let ab, bd & cd edges are removed. The associated spanning tree is

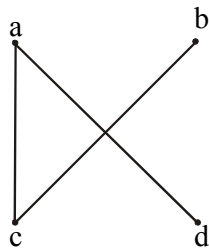

KIRCHHOFF'S THEOREM OR MATRIX - TREE THEOREM

Let M be the matrix obtained from the adjacency matrix of a connected graph G by changing all 1's to -1's and replacing each diagonal 0 by the degree of the corresponding vertex. Then the number of spanning trees of G is equal to the value of any cofactor of M .

EXAMPLE:

Find the number of spanning trees of the graph G .

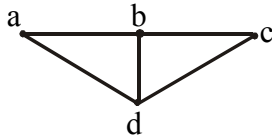

SOLUTION:

The adjacency matrix of G is

$$A(G) = \begin{matrix} & \begin{matrix} a & b & c & d \end{matrix} \\ \begin{matrix} a \\ b \\ c \\ d \end{matrix} & \begin{bmatrix} 0 & 1 & 0 & 1 \\ 1 & 0 & 1 & 1 \\ 0 & 1 & 0 & 1 \\ 1 & 1 & 1 & 0 \end{bmatrix} \end{matrix}$$

The matrix specified in Kirchhoff's theorem is

$$M = \begin{bmatrix} 2 & -1 & 0 & -1 \\ -1 & 3 & -1 & -1 \\ 0 & -1 & 2 & -1 \\ -1 & -1 & -1 & 3 \end{bmatrix}$$

Now cofactor of the element at (1,1) in M is

$$\begin{vmatrix} 3 & -1 & -1 \\ -1 & 2 & -1 \\ -1 & -1 & 3 \end{vmatrix}$$

Expanding by first row, we get

$$\begin{aligned} &= 3 \begin{vmatrix} 2 & -1 \\ -1 & 3 \end{vmatrix} - (-1) \begin{vmatrix} -1 & -1 \\ -1 & 3 \end{vmatrix} + (-1) \begin{vmatrix} -1 & 2 \\ -1 & -1 \end{vmatrix} \\ &= 3(6-1) + (-3-1) + (-1)(1+2) \\ &= 15-4-3=8 \end{aligned}$$

EXERCISE:

How many non-isomorphic spanning trees does the following simple graph has?

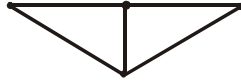
**SOLUTION:**

There are eight spanning tree of the graph

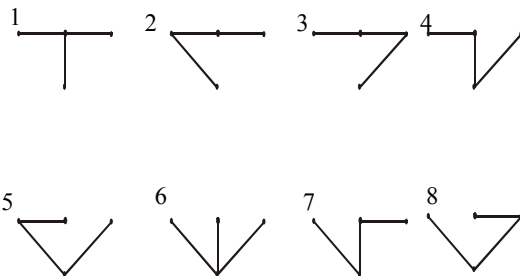

Clearly 1 & 6 are isomorphic, and 2, 3, 4, 5, 7, 8 are isomorphic. Hence there are only two non-isomorphic spanning trees of the given graph.

EXERCISE:

Suppose an oil company wants to build a series of pipelines between six storage facilities in order to be able to move oil from one storage facility to any of the other five. For environmental reasons it is not possible to build a pipeline between some pairs of storage facilities. The possible pipelines that can be build are.

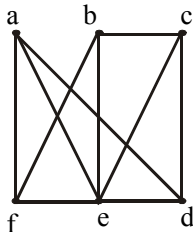

Because the construction of a pipeline is very expensive, construct as few pipelines as possible.

(The company does not mind if oil has to be routed through one or more intermediate facilities)

SOLUTION:

The task is to find a set of edges which together with the incident vertices from a connected graph containing all the vertices and having no cycles. This will allow oil to go from any storage facility to any other without unnecessary building costs. Thus, a tree containing all the vertices of the graph is to be sought. One selection of edges is

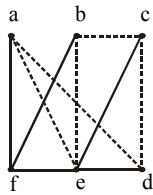

DEFINITION:

A WEIGHTED GRAPH is a graph for which each edge has an associated real number weight.

The sum of the weights of all the edges is the total weight of the graph.

EXAMPLE:

The figure shows a weighted graph

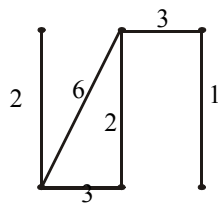

with total weight is $2 + 6 + 3 + 2 + 3 + 1 = 17$

MINIMAL SPANNING TREE:

A minimal spanning tree for a weighted graph is a spanning tree that has the least possible total weight compared to all other spanning trees of the graph.

If G is a weighted graph and e is an edge of G then $w(e)$ denotes the weight of e and $w(G)$ denotes the total weight of G .

EXERCISE:

Find the three spanning trees of the weighted graph below. Also indicate the minimal spanning tree.

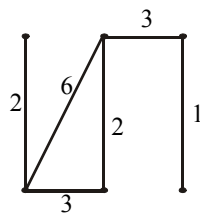

SOLUTION:

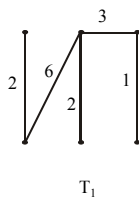

$w(T_1)=14$

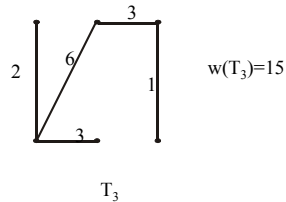
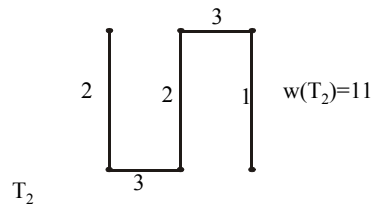

T_2 is the minimal spanning tree, since it has the minimum weight among the spanning trees.

KRUSKAL'S ALGORITHM:

Input: G [a weighted graph with n vertices]

Algorithm:

1. Initialize T (the minimal spanning tree of G) to have all the vertices of G and no edges.
 2. Let E be the set of all edges of G and let $m := 0$.
 3. While ($m < n - 1$)
 - 3a. Find an edge e in E of least weight.
 - 3b. Delete e from E .
 - 3c. If addition of e to the edge set of T does not produce a circuit then add e to the edge set of T and set $m := m + 1$
- end while

Output T

end Algorithm

EXERCISE:

Use Kruskal's algorithm to find a minimal spanning tree for the graph below. Indicate the order in which edges are added to form the tree.

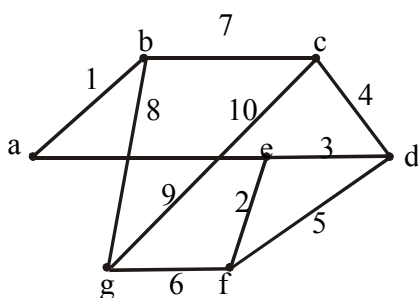

SOLUTION:

Minimal spanning tree:

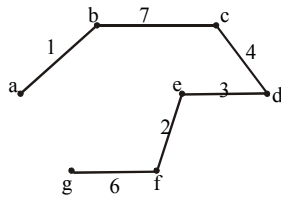

Order of adding the edges:

{a,b}, {e,f}, {e,d}, {c,d}, {g,f}, {b,c}

PRIM'S ALGORITHM:

Input: G [a weighted graph with n vertices]

Algorithm Body:

1. Pick a vertex v of G and let T be the graph with one vertex, v , and no edges.
2. Let V be the set of all vertices of G except v
3. for $i = 1$ to $n - 1$
 - 3a. Find an edge e of G such that
 - (1) e connects T to one of the vertices in V and
 - (2) e has the least weight of all edges connecting T to a vertex in V .
 Let w be the end point of e that is in V .
 - 3b. Add e and w to the edge and vertex sets of T and delete w from V .

next i

Output: T

end Algorithm

EXERCISE:

Use Prim's algorithm starting with vertex a to find a minimal spanning tree of the graph below. Indicate the order in which edges are added to form the tree.

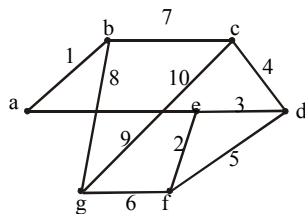

SOLUTION:

Minimal spanning tree is

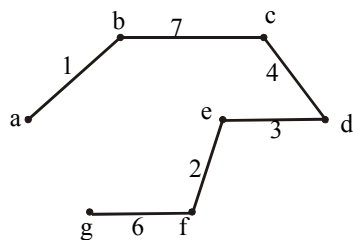

Order of adding the edges:

{a,b}, {b,c}, {c,d}, {d,e}, {e,f}, {f,g}

EXERCISE:

Find all minimal spanning trees that can be obtained using

(a) Kruskal's algorithm

(b) Prim's algorithm starting with vertex a

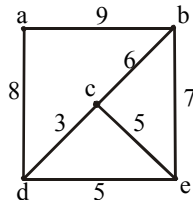

SOLUTION:

Given :

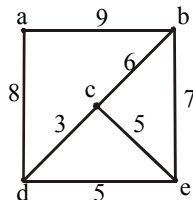

(a) When Kruskal's algorithm is applied, edges are added in one of the following two orders:

1. {c,d}, {c,e}, {c,b}, {d,a}

2. {c,d}, {d,e}, {c,b}, {d,a}

Thus, there are two distinct minimal spanning trees:

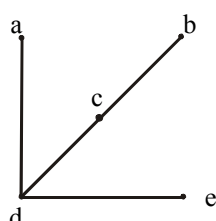
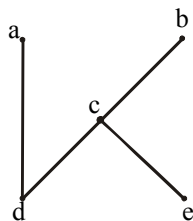

(b)

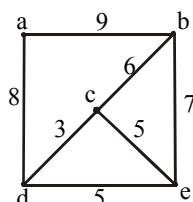

When Prim's algorithm is applied starting at a, edges are added in one of the following two orders:

1. $\{a,d\}, \{d,c\}, \{c,e\}, \{c,b\}$
2. $\{a,d\}, \{d,c\}, \{d,e\}, \{c,b\}$

Thus, the two distinct minimal spanning trees are:

